

# F2004

NURBURGRING GP VERSION

1/20 SCALE STATIC DISPLAY MODEL

GP SERIES N° 001

## 2 - Parts list

### 2.1 - RESIN PARTS

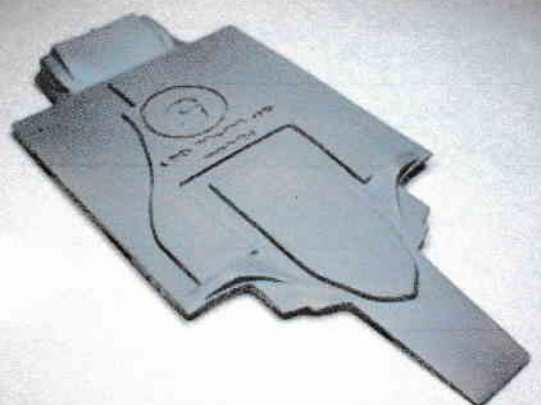
	<p>Part R1</p> <p>Main car body part</p>
	<p>Part R2</p> <p>Floor</p>

### 2.2 - METAL PARTS

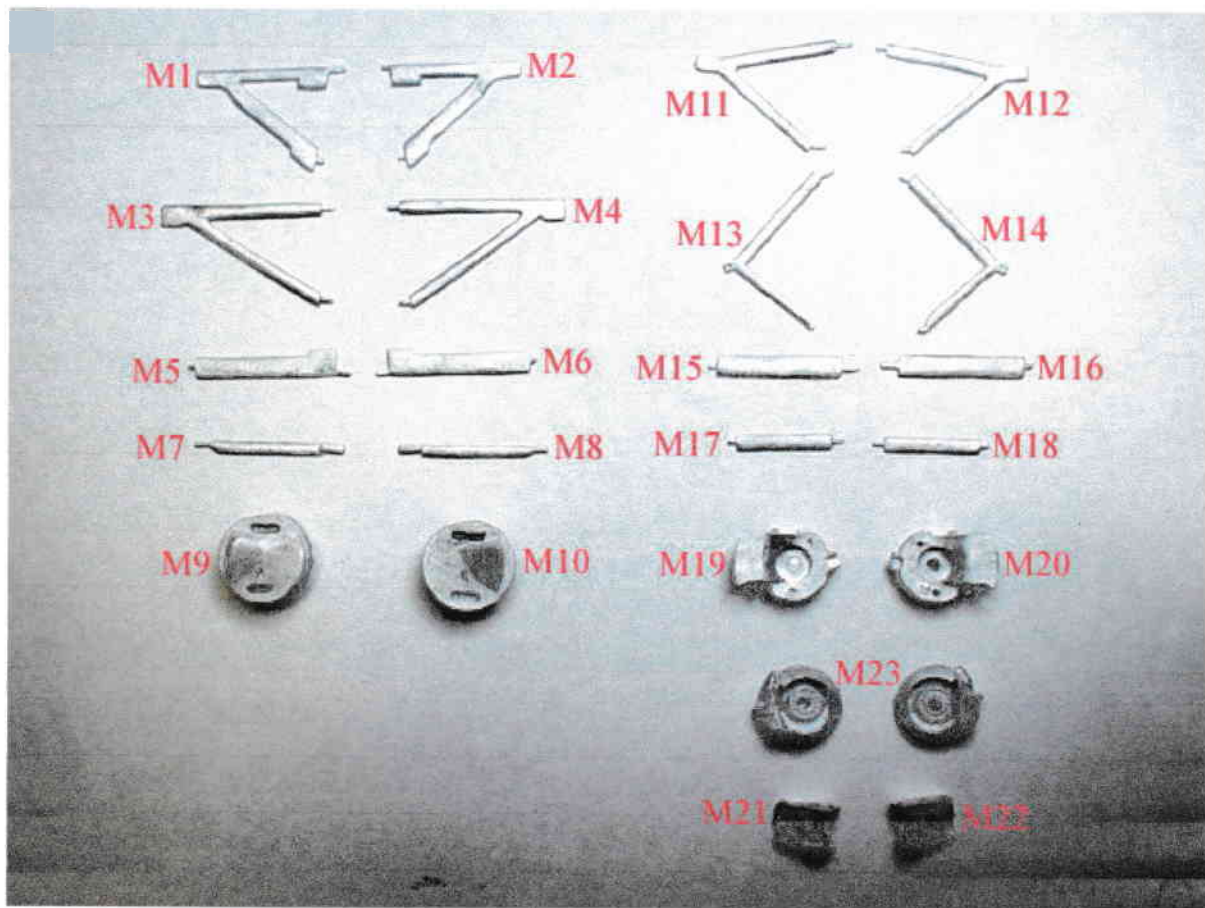

Part M1	Right, front, superior suspension arms
Part M2	Left, front, superior suspension arms
Part M3	Right, front, low suspension arms
Part M4	Left, front, low suspension arms
Part M5	Right, front suspension trigger
Part M6	Left, front suspension trigger
Part M7	Right steering bar
Part M8	Left steering bar
Part M9	Right front brakes/air ducts/wheel mounting
Part M10	Left front brakes/air ducts/wheel mounting
Part M11	Right, rear, superior suspension arms
Part M12	Left, rear, superior suspension arms
Part M13	Right, rear, low suspension arms
Part M14	Left, rear, low suspension arms
Part M15	Right, rear suspension arms
Part M16	Left, rear suspension arms
Part M17	Right, rear suspension trigger
Part M18	Left, rear suspension trigger
Part M19	Right rear brakes ducts/wheel mounting
Part M20	Left rear brakes ducts/wheel mounting
Part M21	Right rear brakes ducts/wheel mounting cover
Part M22	Left rear brakes ducts/wheel mounting cover
Part M23	Rear brake set(2X)

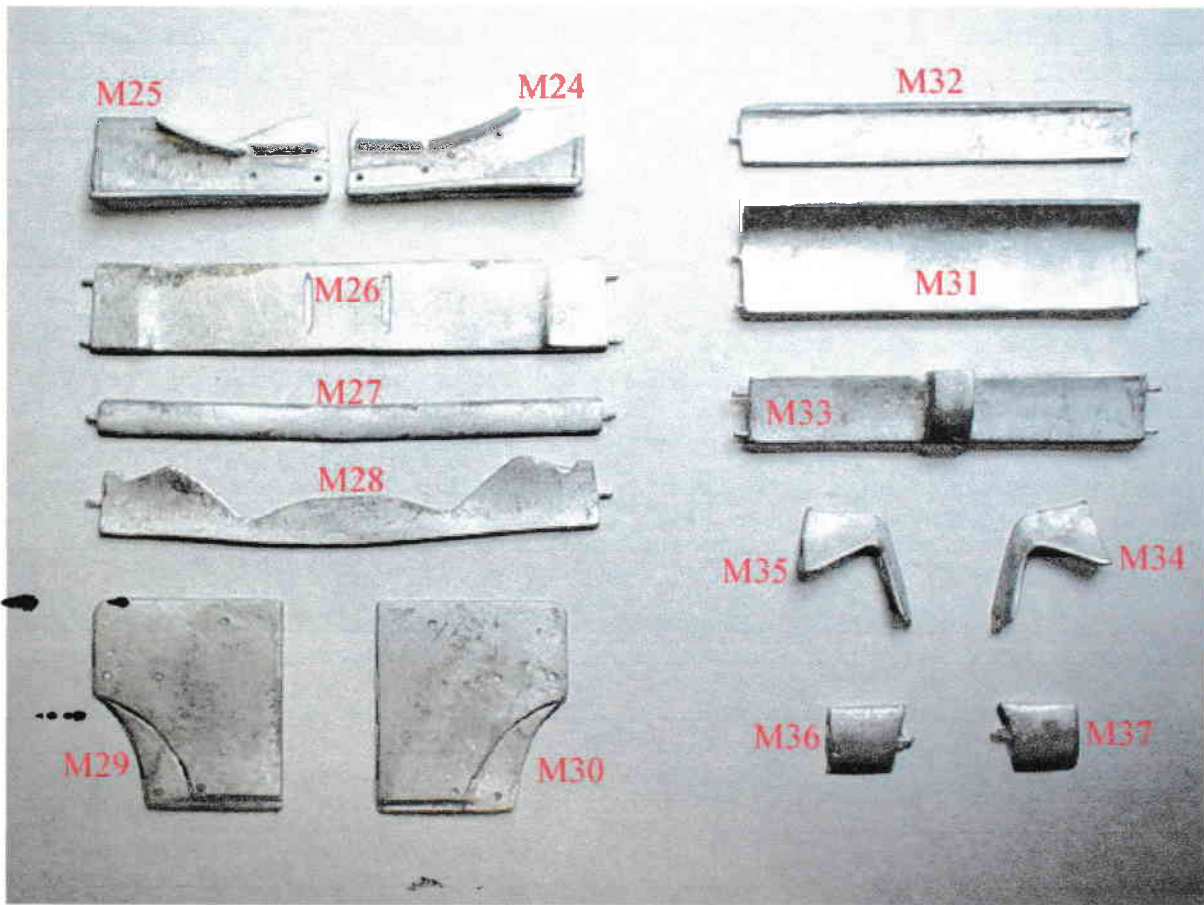

Part M24	Right, front wing side board
Part M25	Left, front wing side board
Part M26	Front wing part 1
Part M27	Front wing part 2
Part M28	Front wing part 3
<b>Part M29</b>	<b>Right, rear wing side board</b>
Part M30	Left, rear wing side board
Part M31	<b>Rear wing part 1</b>
Part M32	Rear wing part 2
Part M33	Rear wing part 3
Part M34	Right side small wings
Part M35	<b>Left side small wings</b>
Part M36	Right wing over the cowling
Part M37	Left wing over the cowling

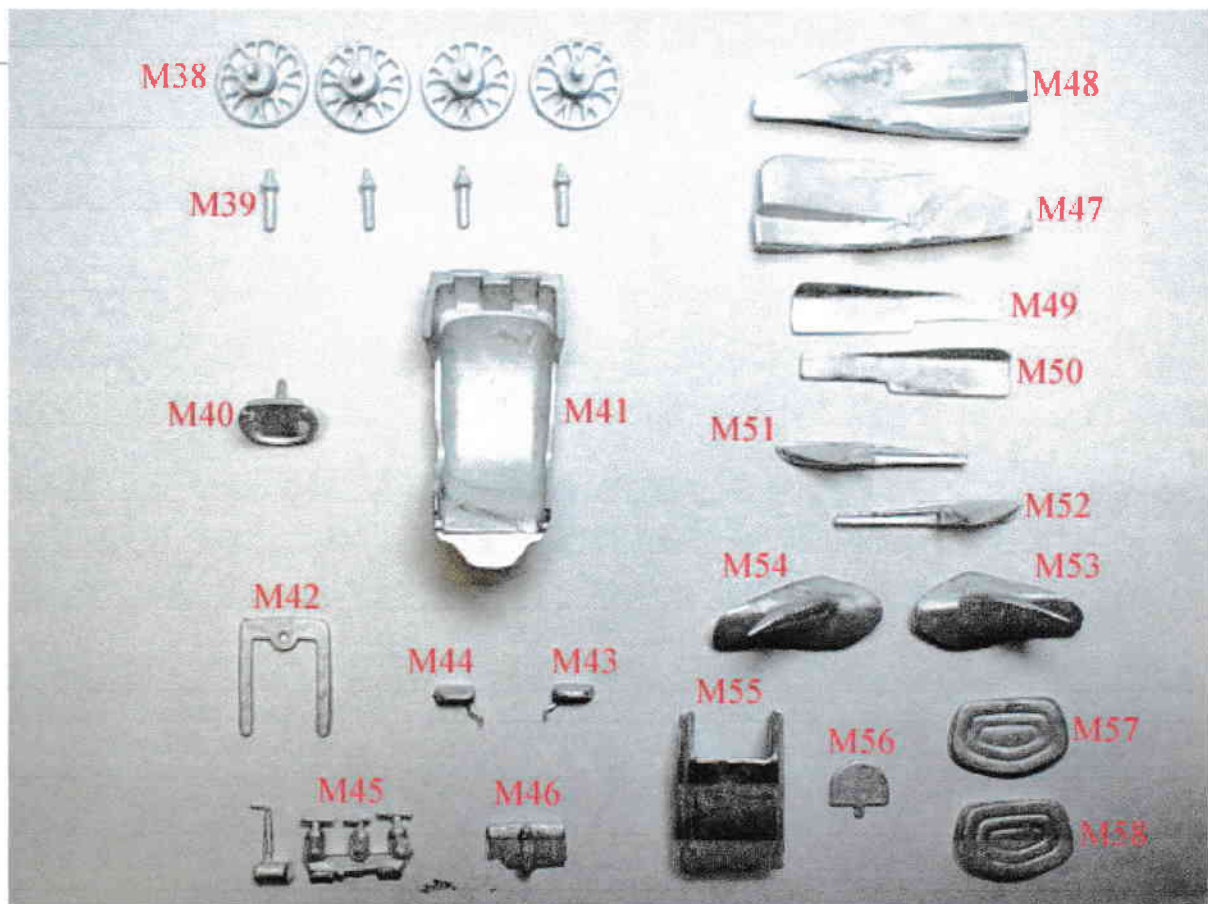

Part M38	Wheels center part (4X)
Part M39	Wheel lock nuts(4X)
Part M40	Steering wheel
<b>Part M41</b>	<b>Drivers seat</b>
Part M42	Steering wheel suport
Part M43	Right rear view mirror
Part M44	Left rear view mirror
Part M45	<b>Antennas</b>
Part M46	T-Cam
Part M47	Barge board 1/1 right
Part M48	<b>Barge board 1/1 left</b>
Part M49	<b>Barge board 2/1 right</b>
Part M50	Barge board 2/1 left
Part M51	Right exhaust and covers
<b>Part M52</b>	<b>Left exhaust and covers</b>
Part M53	Right side chimney
Part M54	Left side chimney
Part M55	Air extractor
Part M56	Drivers head rest
Part M57	Drivers right shoulders rest
Part M58	Drivers lefy shoulders rest

## 2.3 - OTHER PARTS



Part D1	Front aluminum rims(2X)
Part D2	Left aluminum rims (2X)
Part D3	Front rubber tyres (2X)
Part D4	Rear rubber tyres(2X)
Part D5	Hardwood plank
Part D6	Wind shield
Part D7	Rain light cover
Part D8	rear traction axle(2X)

2.4 - PHOTOETCHED

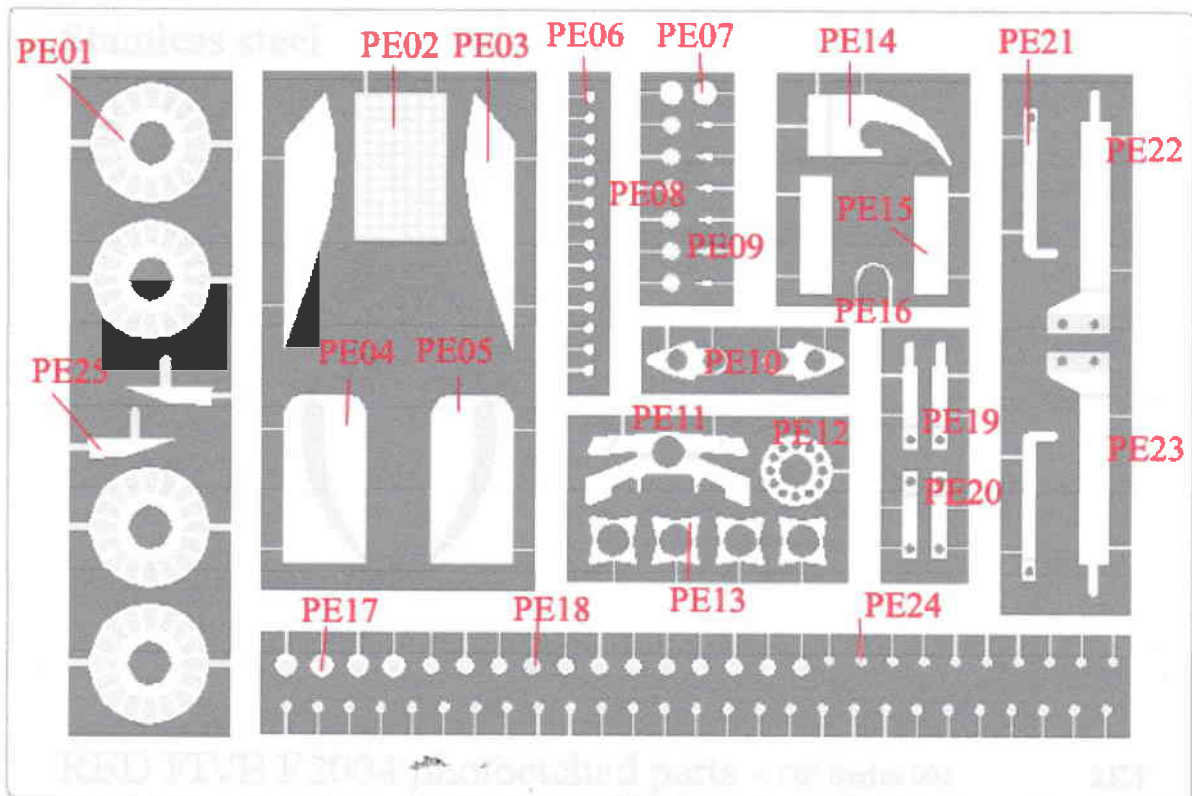

**Part PE01** Wheels lock nuts(4X)**Part PE02**Rear rain lights**Part PE03**Barge board 1/2 (2X)**Part PE04**Left lateral small wing (2X)**Part PE05**Right lateral small wing (2X)**Part PE06**Steering wheel buttons/switches 1 (14X)**Part PE07**Steering wheel buttons/switches 2 (2X)**Part PE08**Steering wheel buttons/switches 3/1 (6X)**Part PE09**Steering wheel buttons/switches 3/2 (6X)**Part PE10**Front suspension fittings(2X)**Part PE11**Gear shift and clutch levers**Part PE12**Steering wheel eject mechanism**Part PE13**Steering wheel fittings(4X)**Part PE14**Rear jack support**Part PE15**Rear view mirrors(2X)**Part PE16**Fire extinguisher trigger**Part PE17**Nuts 1,2 mm (4X)**Part PE18**Nuts 0,9mm (12X)**Part PE19**Barge boards supports 1 (2X)**Part PE20**Barge boards supports 2 (2X)**Part PE21**Barge boards supports 3 (2X)**Part PE22**Barge boards supports 4 direita**Part PE23**Barge boards supports 4 esquerda**Part PE24**Nuts 0,6 mm (37X)**Part PE25**Small air deflectors

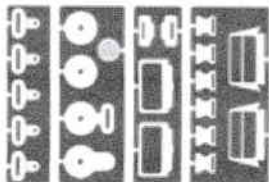

(2X)

F1 Seat belt harness set



**Decal sheet - F2004 Nurburgring GP version**



**Scale Motorsports 1420 Carbon fiber templated decals**



**Scale Motorsports 1020 Carbon fiber templated decals**

**Bare Metal foil Chrome and Gold**

# F2004

## NURBURGRING GP VERSION

1/20 SCALE STATIC DISPLAY MODEL

GP SERIES N° 001

### 3 - Body and floor preparation

#### 3.1 - STEP 1

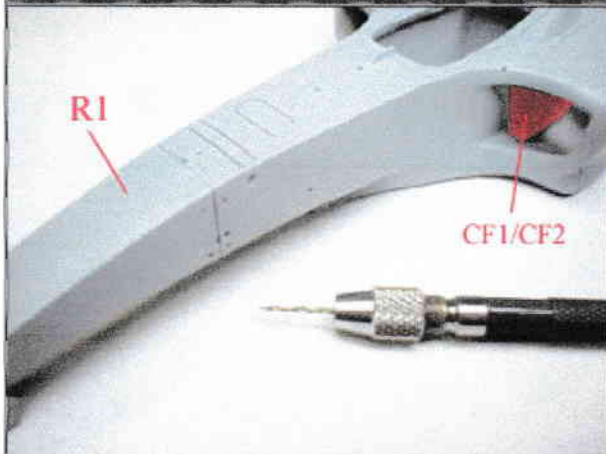

Using a pin vise, make the necessary holes on the part R1. Study this manual to know every hole you need to drill.

Carbon fiber decals CF1 and CF2 must be applied where indicated, after painting the body.

#### 3.2 - STEP 2

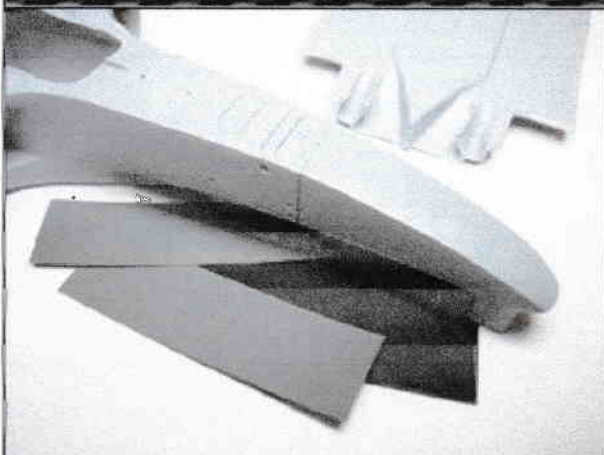

With putty and sandpaper, get rid of any mold lines, resin air bubbles, and other imperfections..

#### 3.3 - STEP 3

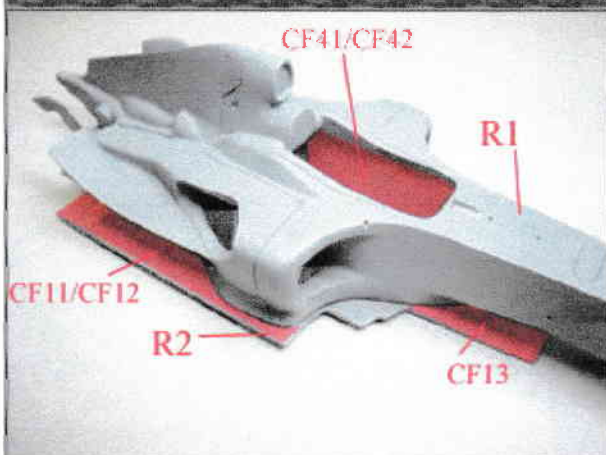

Adjust the fit between parts R1 and R2, if necessary.

Carbon fiber decals CF11, CF12, CF13, CF41 and CF42 must be applied where indicated, after painting.

#### 3.4 - STEP 4

Adjust the fitting of the parts M53 and M54. It's a good idea to adjust and glue this parts on the car before start painting.



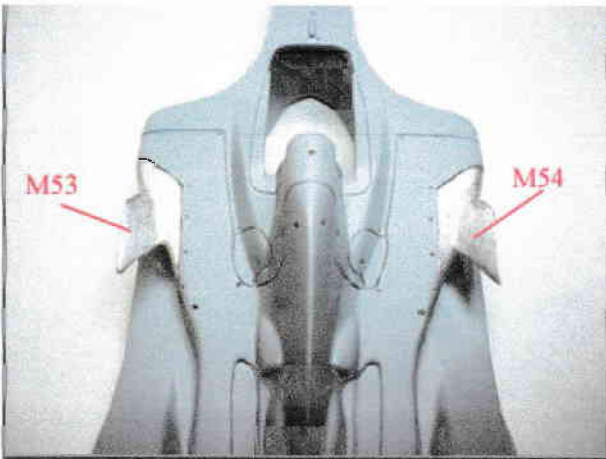

[Reference picture](#)

3.5 - STEP 5

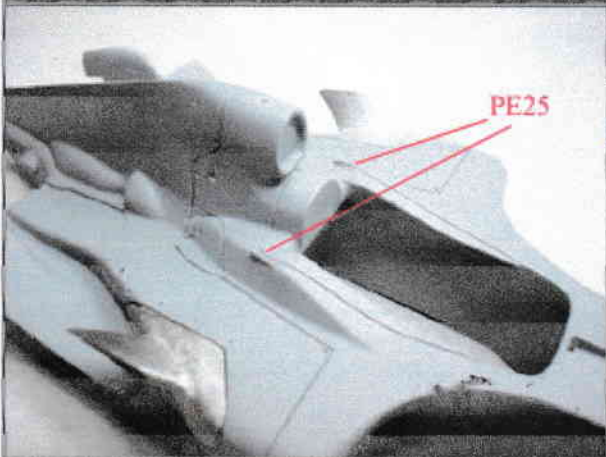

Glue part PE25, and get rid of the joint line with putty.

[Reference picture](#)

3.6 - STEP 6

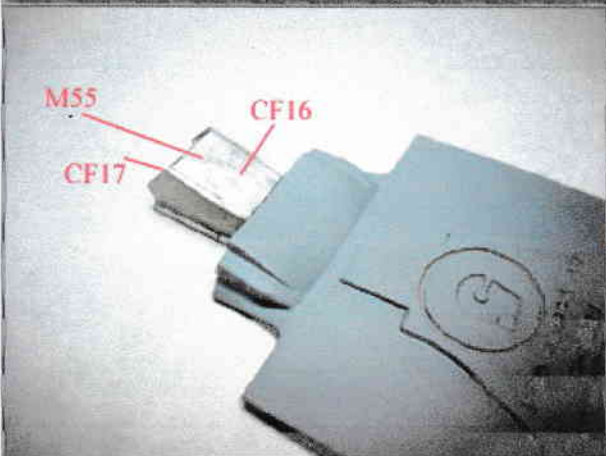

Glue part M55 on part R2 e get rid of the joint line with putty.

Carbon fiber decals CF16 and CF17 must be applied were indicated, after painting

[Reference picture](#)

# F2004

NURBURGRING GP VERSION  
1/20 SCALE STATIC DISPLAY MODEL  
GP SERIES N° 001

## 4 - Wheels

<p>4.1 - STEP 1</p> 	<p>Glue parts PE01 and M39 on part M38, for each wheel.</p>
<p>4.2 - STEP 2</p> 	<p>Glue part M38 on the aluminum rims D1 and D2.</p>
<p>4.3 - STEP 3</p> 	<p>Install tyres D3 and D4 on the wheels. <a href="#">Reference pictures</a></p>

# F2004

## NURBURGRING GP VERSION

1/20 SCALE STATIC DISPLAY MODEL

GP SERIES N° 001

### 5 - Front suspension

#### 5.1 - STEP 1

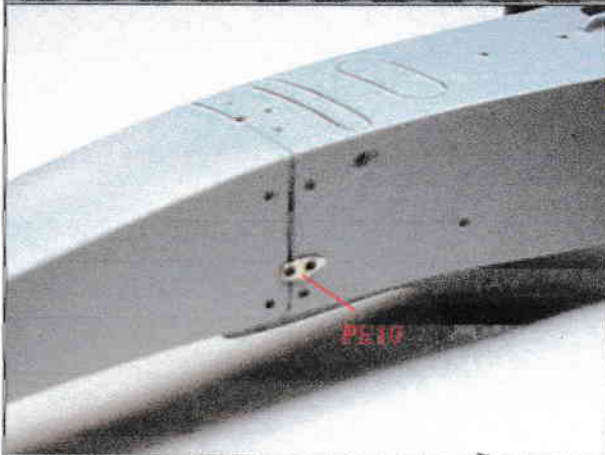

Glue PE 10 at part R1.

[Reference picture](#)

#### 5.2 - STEP 2

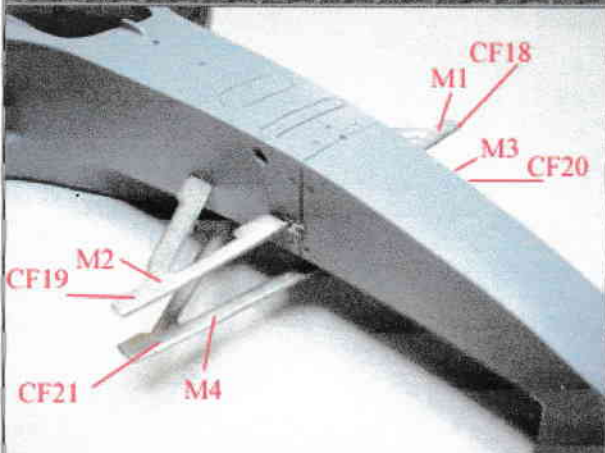

Glue parts M1, M2, M3 e M4 at R1.

Carbon fiber decals CF18, CF19, CF20 and CF21 must be applied where indicated, after painting.

#### 5.3 - STEP 3

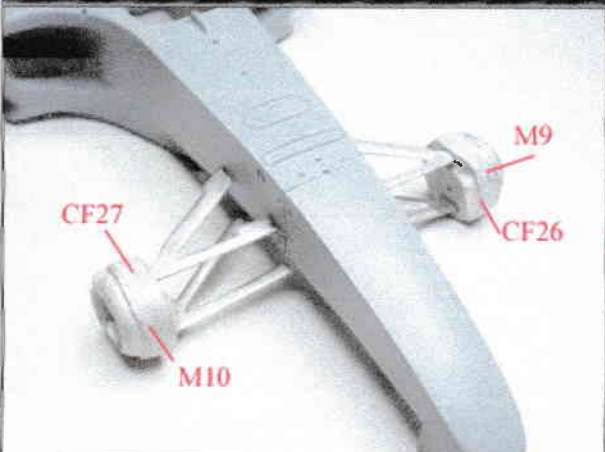

Glue parts M9 and M10. Check the alignment using the wheels before gluing.

Carbon fiber decals CF26 and CF27 must be applied where indicated, after painting.

[Reference pictures](#)

#### 5.4 - STEP 4

Glue parts M5, M6, M7, M8. Check the ride height of the car using the wheels, before gluing.

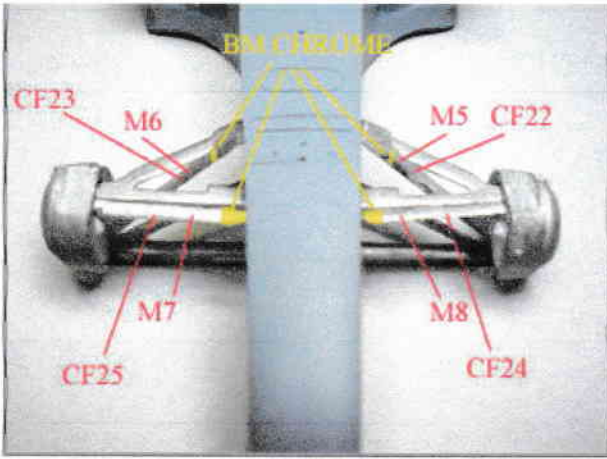

Carbon fiber decals CF22, CF23, CF24 and CF25 must be applied where indicated, after painting.

# F2004

## NURBURGRING GP VERSION

### 1/20 SCALE STATIC DISPLAY MODEL

#### GP SERIES N° 001

## 6 - Rear Suspension

### 6.1 - STEP 1

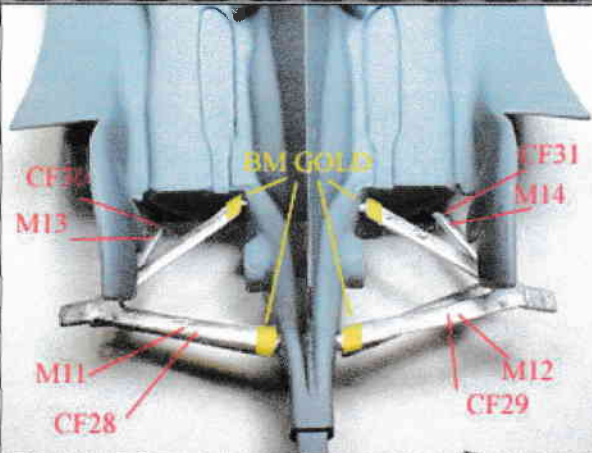

Glue parts M11, M12, M13, M14 at R1.

Carbon fiber decals CF28, CF29, CF30 and CF31 must be applied where indicated, after painting.

### 6.2 - STEP 2

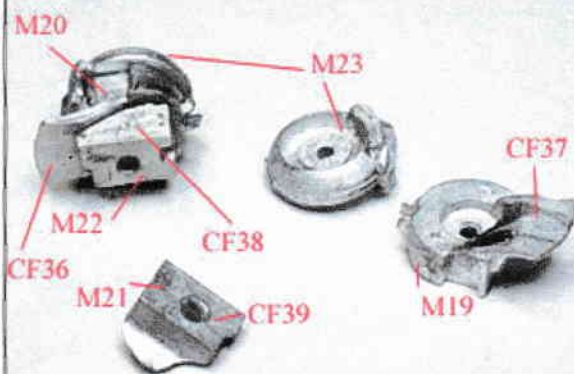

Glue parts M19, M20 and M23 at parts M21 and M22.

### 6.3 - STEP 3

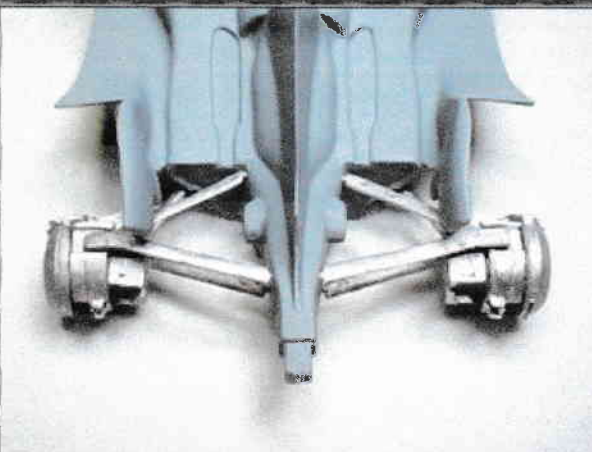

Glue parts M21 and M22 at the suspension parts already fixed to R1. Check the alignment using the wheels before gluing.

### 6.4 - STEP 4

Glue parts M15, M16, M17, M18 and D8 at R1, completing the suspension. Check the ride height of the car with the wheels, before gluing.

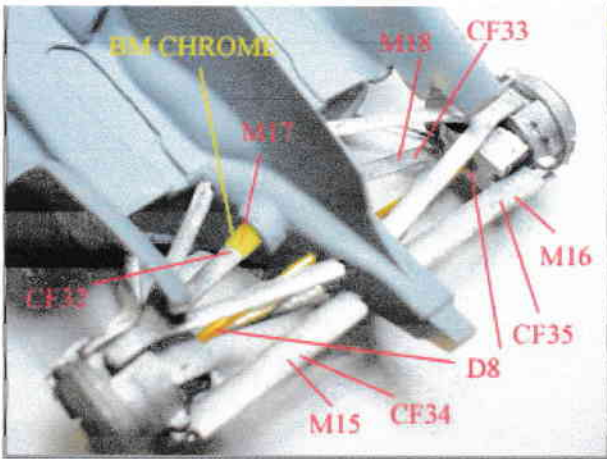

[Reference pictures](#)

# F2004

## NURBURGRING GP VERSION

1/20 SCALE STATIC DISPLAY MODEL  
GP SERIES N° 001

### 7 - Front wing

#### 7.1 - STEP 1

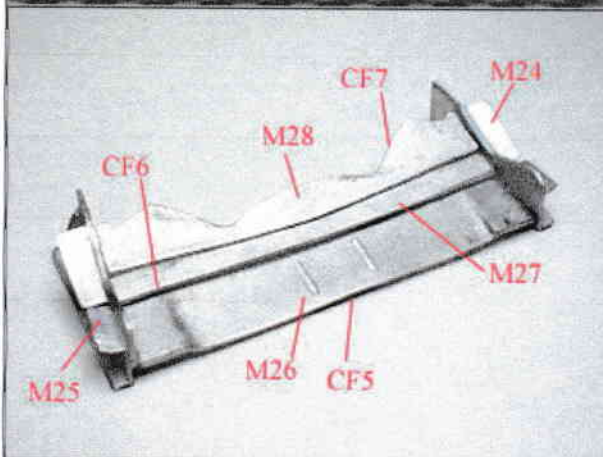

Glue parts M24, M25, M26, M27 and M28 together.  
Double check the correct alignment of the parts.

Carbon fiber decals CF5, CF6 and CF7 must be applied were indicated, after painting.

#### 7.2 - STEP 2

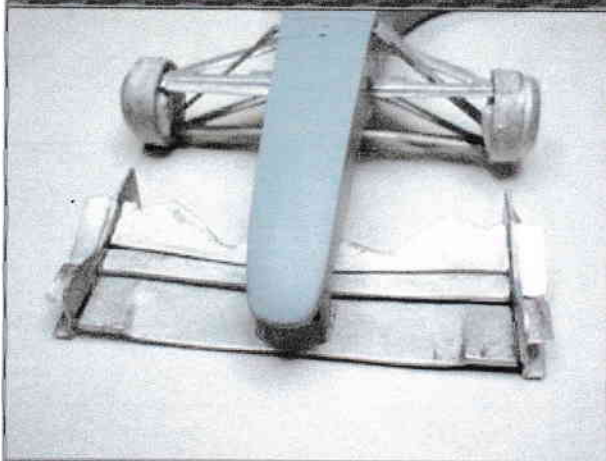

Glue the **complete wing** at R1.

[Reference pictures](#)

# F2004

## NURBURGRING GP VERSION

1/20 SCALE STATIC DISPLAY MODEL

GP SERIES N° 001

### 8 - Rear wing

#### 8.1 - STEP 1

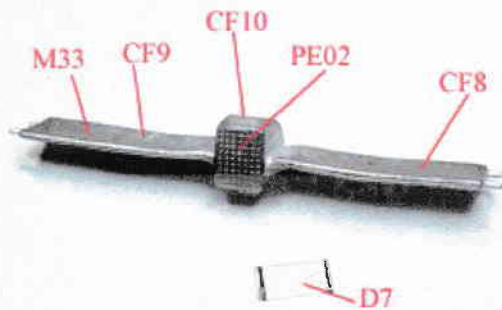

Glue part PE02 and D7 at part M33.

Carbon fiber decals CF8, CF9 and CF10 must be applied were indicated, after painting.

#### 8.2 - STEP 2

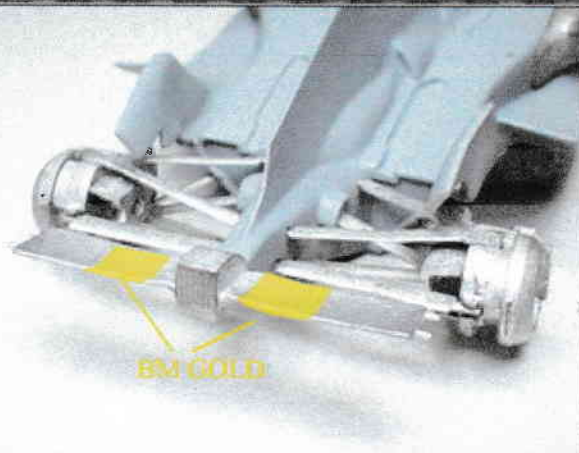

Glue part M33 at R1. Check the alignment before gluing.

#### 8.3 - STEP 3

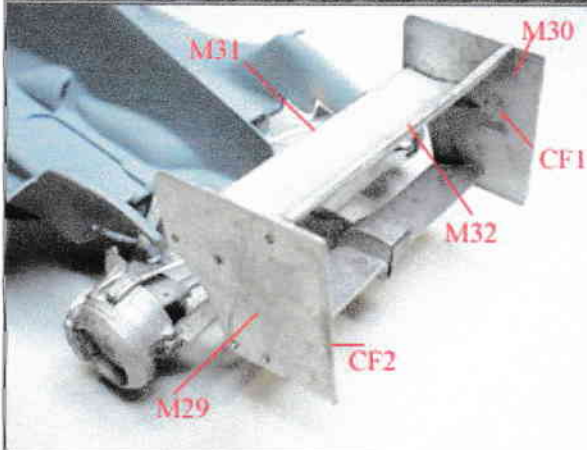

Glue parts M29, M30, M31 and M32. Check all the angles before gluing to get a perfect straight result.

Carbon fiber decals CF1 and CF2 must be applied were indicated, after painting.

[Reference pictures](#)



# F2004

## NURBURGRING GP VERSION

1/20 SCALE STATIC DISPLAY MODEL

GP SERIES N° 001

### 9 - Barge boards

#### 9.1 - STEP 1

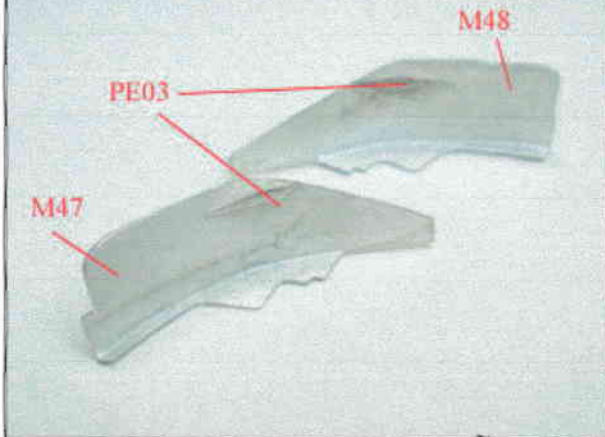

Glue the PE03 at parts M47 e M48.

[Reference pictures](#)

#### 9.2 - STEP 2

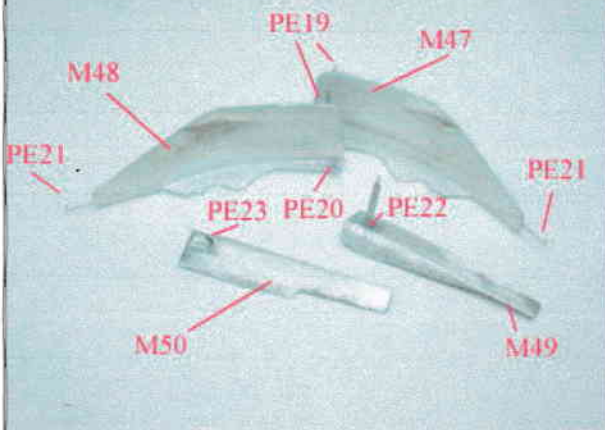

Glue parts PE19, PE20, PE21, PE22 and PE23 at parts M47, M48, M49 e M50.

#### 9.3 - STEP 3

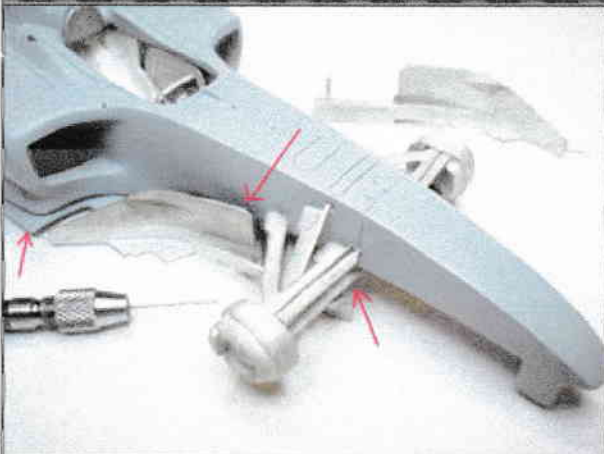

Using the barge boards, verify the right place to drill the 3 fitting holes on the R1 part, as indicated on the picture.

#### 9.4 - STEP 4

Install the barge boards to the car.

**Recomendation:** This is probably the last part to glue to the model, as the supports are really thin and fragile

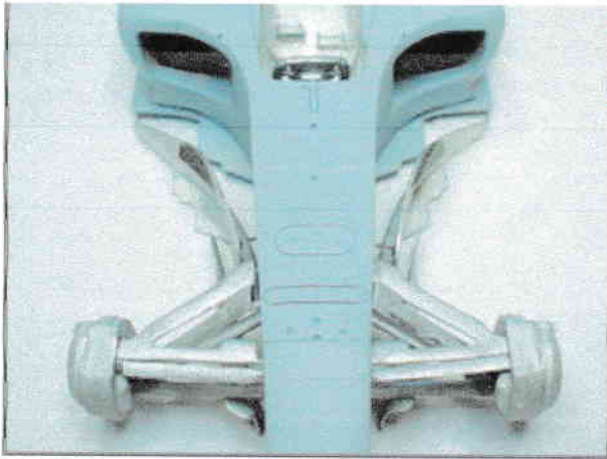

to be on the right scale.

[Reference pictures](#)

# F2004

## NURBURGRING GP VERSION

1/20 SCALE STATIC DISPLAY MODEL

GP SERIES N° 001

### 10 - Cockpit

#### 10.1 - STEP 1

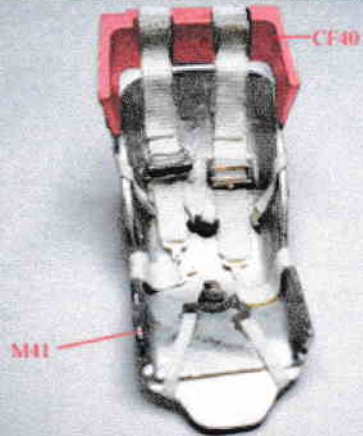

Install the PE seat belt harness to the part M41, following the printed instructions that came with the set.

[Reference picture](#)

#### 10.2 - STEP 2

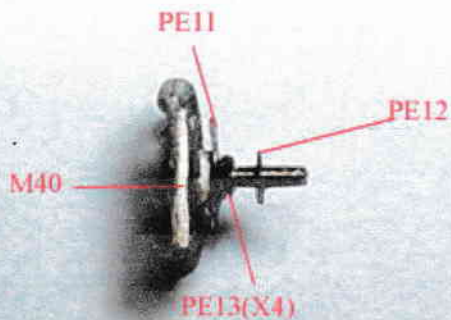

Glue parts PE11, PE12 and PE13 at part M40.

[Reference picture](#)

#### 10.3 - STEP 3

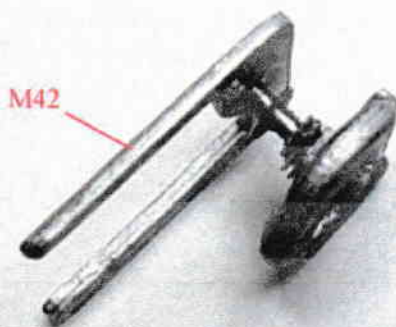

Glue part M40 at part M42.

#### 10.4 - STEP 4

In case you choose the complete steering wheel detail, glue the PE06, PE07, PE08 and PE09 at the template decal number 57. In case you choose the simple detail level, just apply the decal 56, and the wheel is done.

[Reference pictures](#)

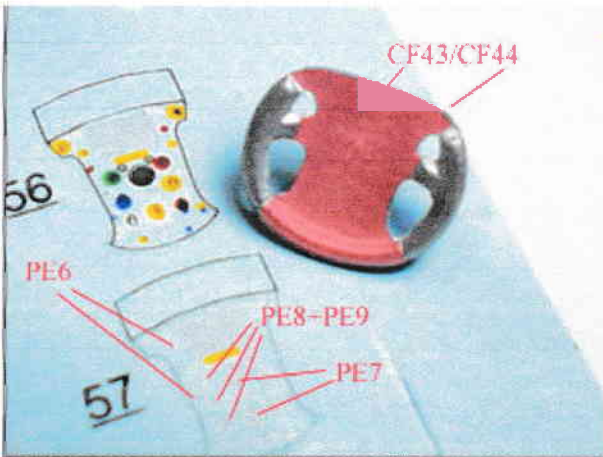

10.5 - STEP 5

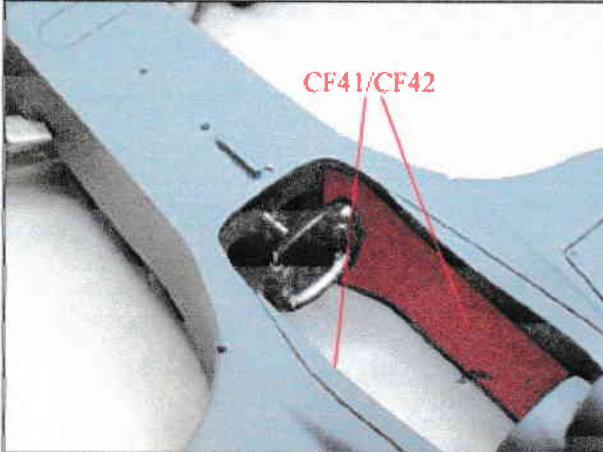

Glue the complete wheel at R1.

Carbon fiber decals CF41 and CF42 must be applied were indicated, after painting.

10.6 - STEP 6



Glue parts M57 e M58 at R1.

10.7 - STEP 7

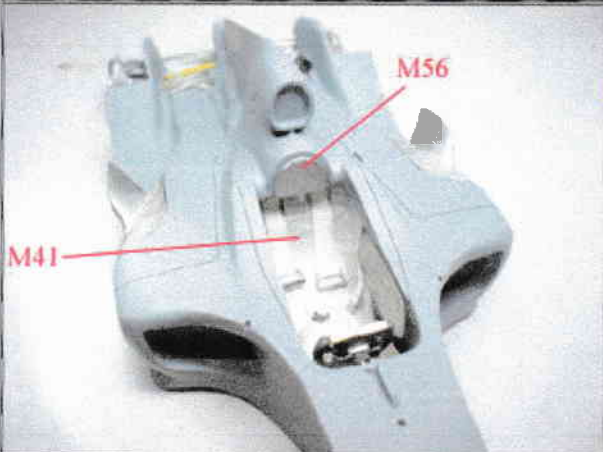

Glue parts M56 e M41 at R1.

[Reference pictures](#)

# F2004

## NURBURGRING GP VERSION

1/20 SCALE STATIC DISPLAY MODEL

GP SERIES N° 001

### 11 - Accessories

#### 11.1 - STEP 1

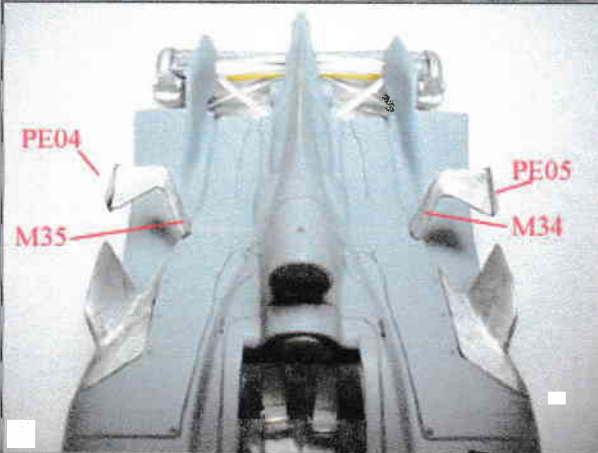

Glue parts PE04 and PE05 at parts M34 e M35 respectively. The glue parts M34 and M35 at R1.

[Reference pictures](#)

#### 11.2 - STEP 2

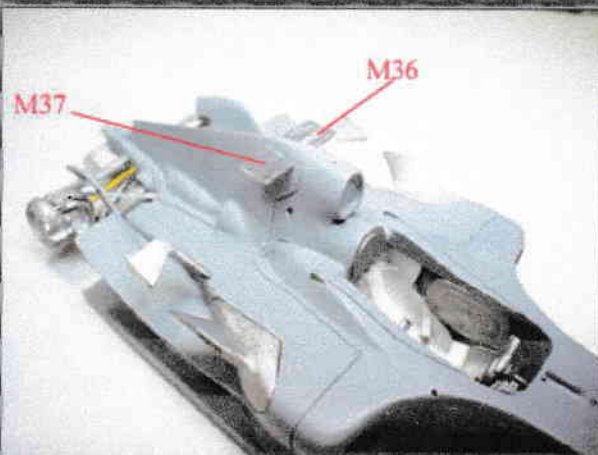

Glue parts M36 and M37 at R1.

[Reference pictures](#)

#### 11.3 - STEP 3

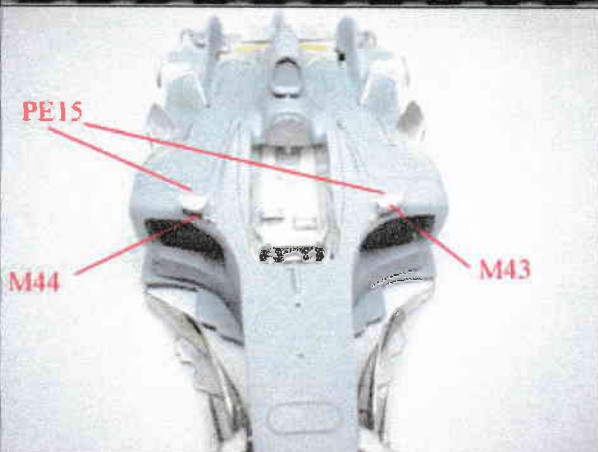

Glue parts PE15 at parts M43 e M44. The glue M43 and M44 at R1.

[Reference pictures](#)

#### 11.4 - STEP 4

Glue parts M46 at R1.

Carbon fiber decals CF45, CF46, CF47 and CF48 must be applied where indicated, after painting.

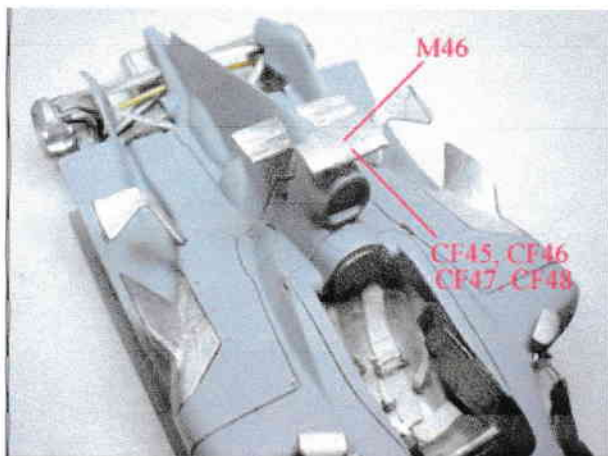

Attention: The templated CF decal 45 is inverted, and must be adjusted.

[Reference pictures](#)

11.5 - STEP 5

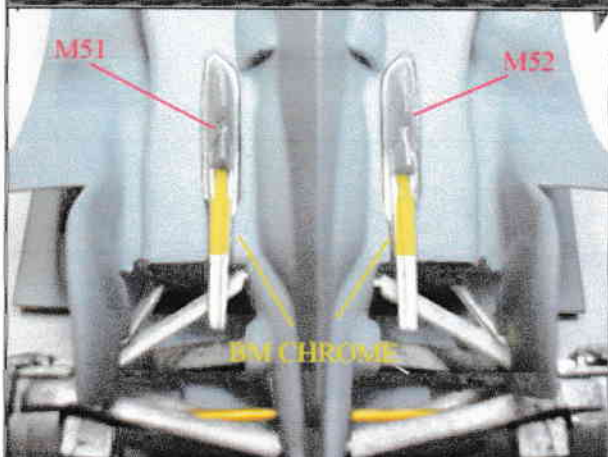

Glue parts M51 e M52 at R1.

[Reference pictures](#)

11.6 - STEP 6

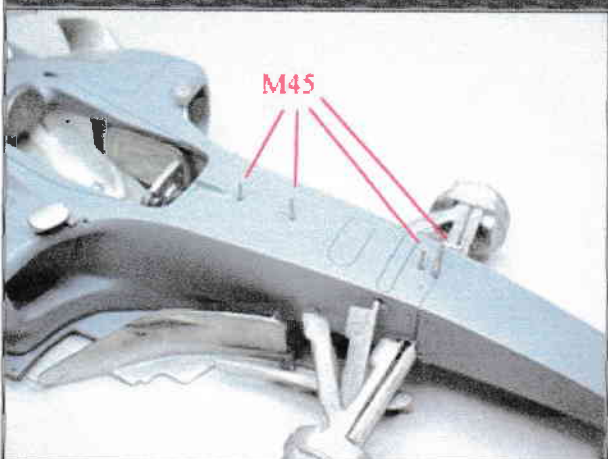

Split part M45, then glue the antennas at R1.

[Reference pictures](#)

11.7 - STEP 7



Install the wheels at the car.

Last chance to correct any alignment mistakes.

11.8 - STEP 8

Instal D6 at R1

[Reference pictures](#)

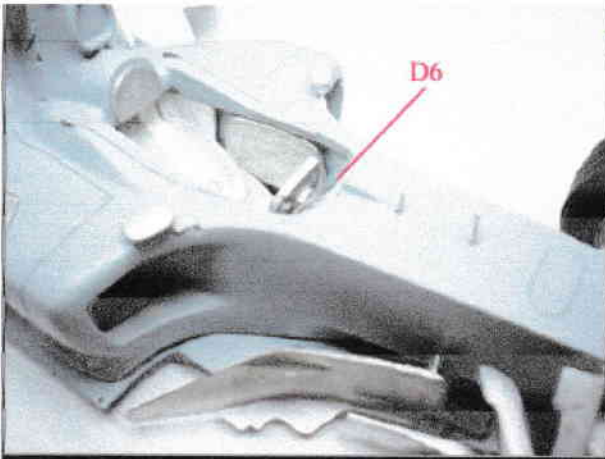

11.9 - STEP 9

Glue part D5 at R2.

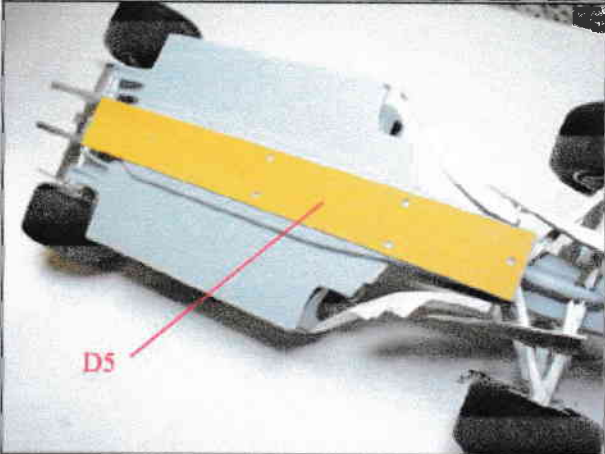

11.10 - STEP 10

Install the PE14 at part M55

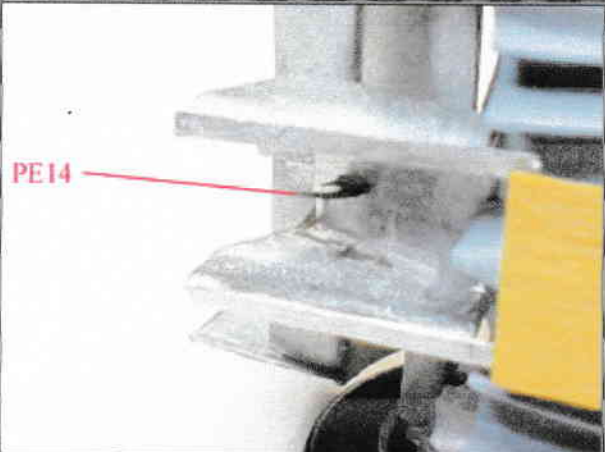

11.11 - STEP 11

Glue the PE16 at R1.

[Reference picture](#)

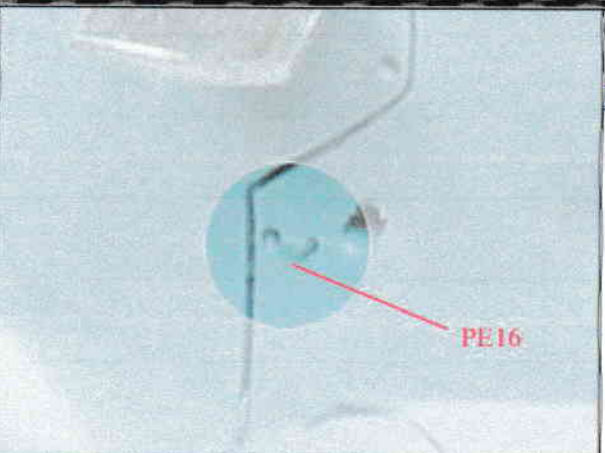

11.12 - STEP 12

Glue parts PE17, PE18 and PE24 at the car, following the reference pictures.

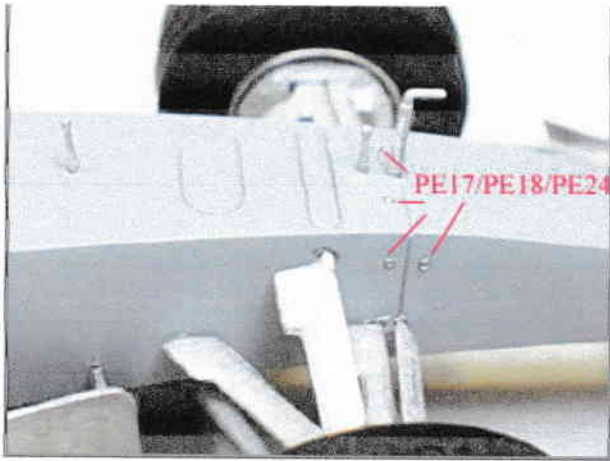



# F2004

## NURBURGRING GP VERSION

1/20 SCALE STATIC DISPLAY MODEL

GP SERIES N° 001

### 12 - Decals

