

1/20 Scale Metal KIT

Lancia Ferrari D50

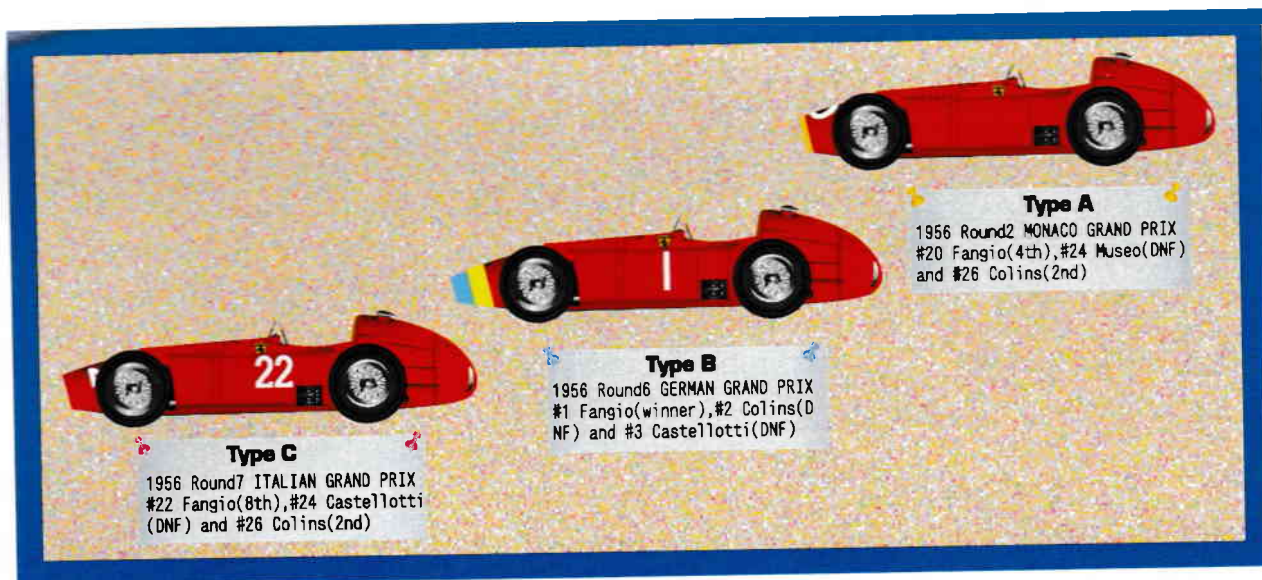

Type A

1956 Round2 MONACO GRAND PRIX
#20 Fangio(4th), #24 Museo(DNF)
and #26 Colins(2nd)

Type B

1956 Round6 GERMAN GRAND PRIX
#1 Fangio(winner), #2 Colins(DNF)
and #3 Castellotti(DNF)

Type C

1956 Round7 ITALIAN GRAND PRIX
#22 Fangio(8th), #24 Castellotti
(DNF) and #26 Colins(2nd)

PARTS LIST

H-1	wheel rim A	4
H-2	wheel rim B	4
H-3	wheel rim C	2
H-4	wheel rim D	2
H-5	hub	4
H-6	meter (big)	2
H-7	meter (small)	3
H-8	horn bottom	1
H-9	funnel	8
H-10	head volt	40
H-11	front dumper	2
H-12	cup	1
H-13	rivet	2
H-14	stainress ball	2
P-1	brass rod [φ:1mm, L:10mm]	1
P-2	vinyl cord(red) [φ:0.5mm, L:200mm]	1
P-3	vinyl cord(brack) [φ:0.5mm, L:200mm]	1
P-4	vinyl tube(brack)[φ:1.8mm, L:200mm]	1
S-1	screw(brack)	6
K-1	wind sheild[20mm x 20mm]	1

Color table

(注) この説明書ではグンゼ産業
(GS Iクレオス)のMr. Colorを使用しています。

notice. The color, using on this instruction
is Mr. color, from GUNZE SANGYO(GSI CREOS).

1	白	white
2	黒	black
8	シルバー	silver
11	ガルグレー	gull gray
33	ツヤ消し黒	flat black
44	タン	tan
92	半ツヤ黒	semi gloss black
158	スーパーイタリアン レッド	super italian red

磨き出しは図で表示させて頂いています。
the polish is explained as図.

お知らせ
製品には細心の注意を払っておりますが、ごく
まれに製品に不備のある場合がございます。
そのときはお気軽にご連絡ください。

Notice
We are handling the kit very carefully
But unusualy the kit would be imperfect.
If you had any problem..please contact us.

1 ENGINE ASSEMBLY

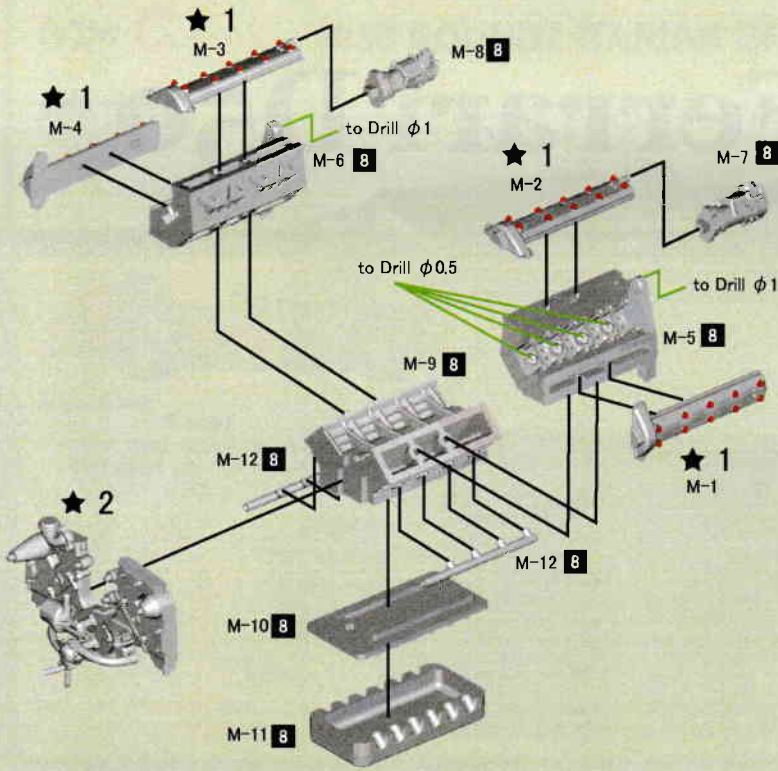

★ 1 HEADCOVER

4つ作ります。
Make 4 sets.

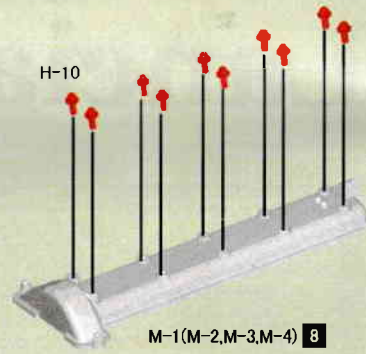

2 DEDION ASSEMBLY

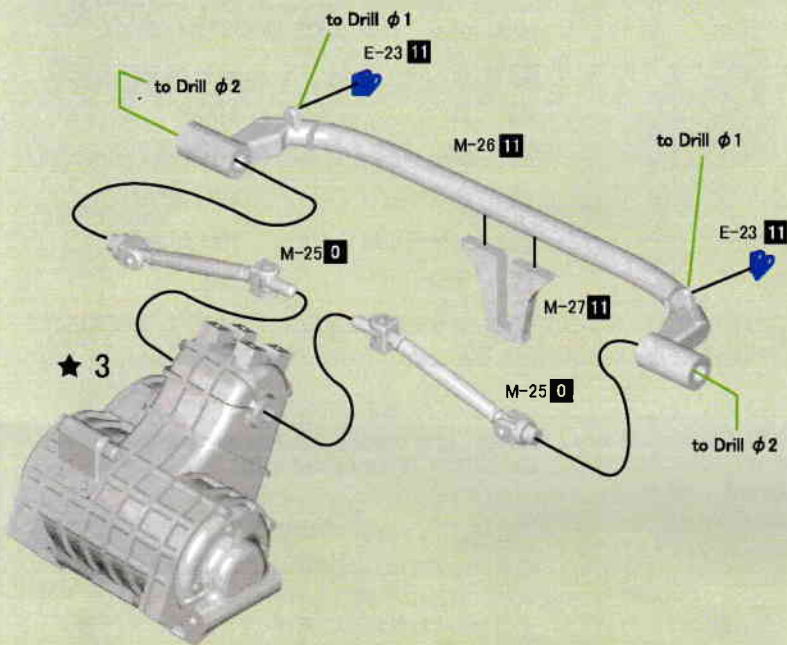

★ 2 FRONTCOVER

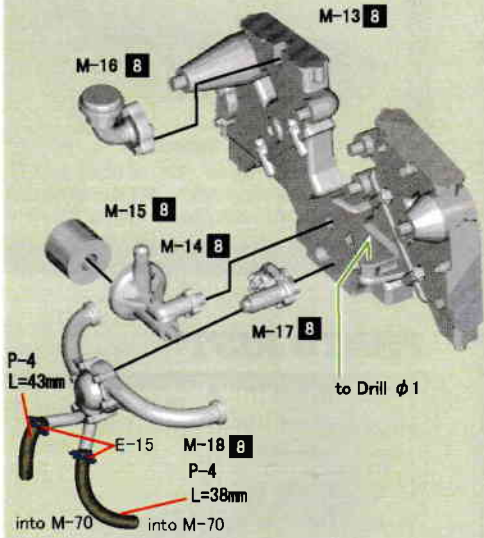

★ 3 MISSION ASSEMBLY

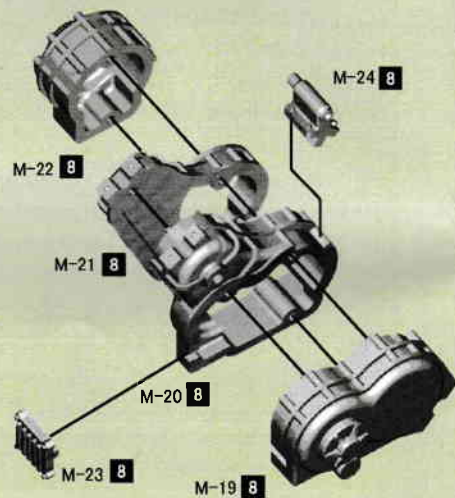

3 FLAME ASSEMBLY

(UPPER)

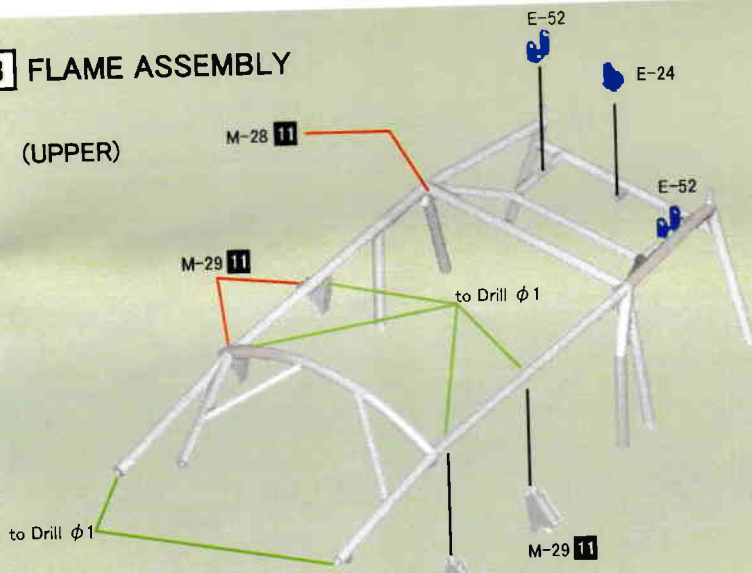

(RIGHT SIDE)

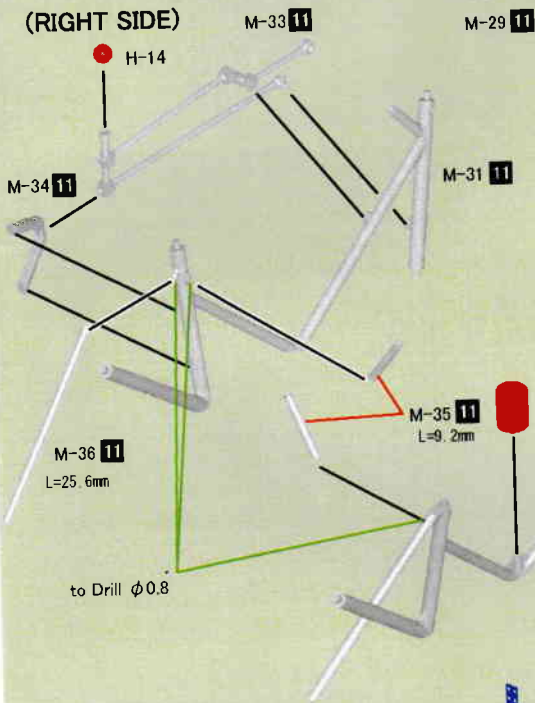

(LEFT SIDE)

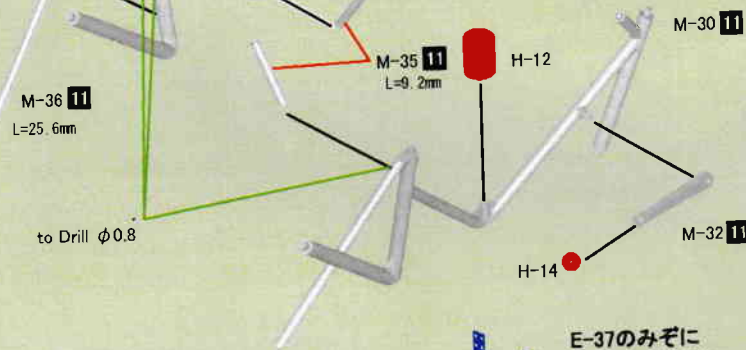

(UNDER) ★ 4

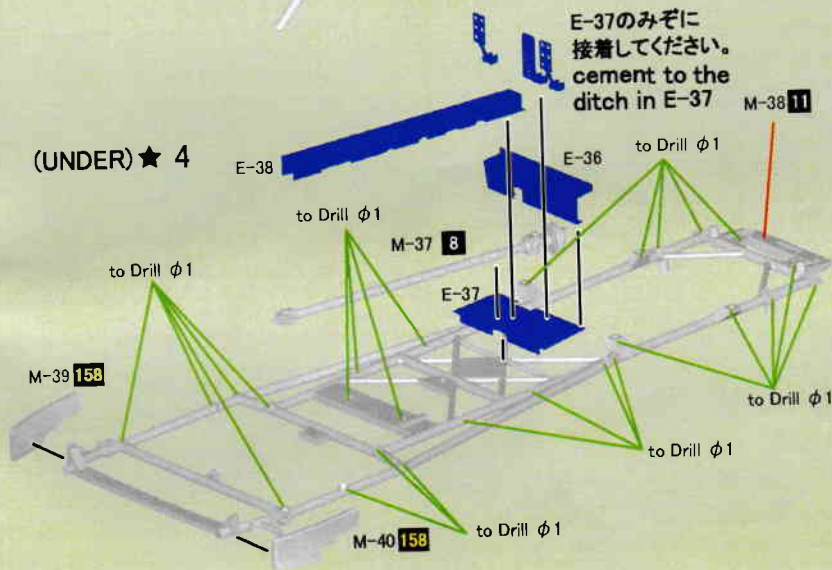

★ 4

E-52

2個作ります。 Make 2.

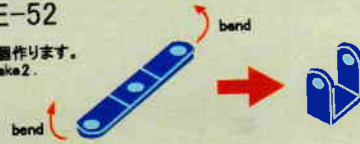

E-24



PEDAL

3個作ります。 Make 3.



2個作ります。 Make 2.



E-36

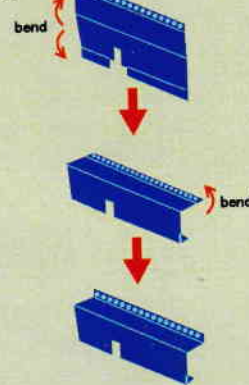

E-37

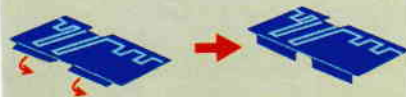

E-38

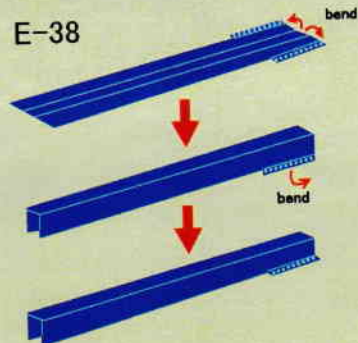

4

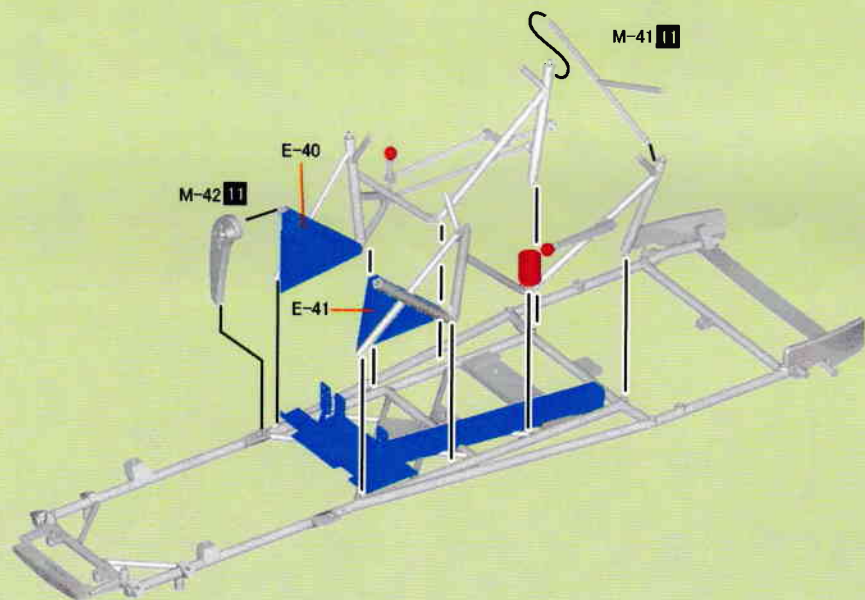

5 VALKHEAD

E-43の両わきをペンチで折りまげ㊦のみぞにあうよう成形してください。

Please bend the both edge of E-43 by plier to adjust to fit the shape of ditch in ㊦.

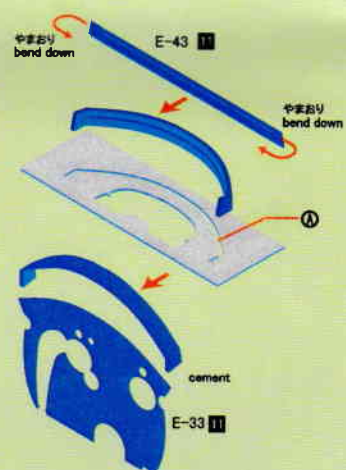

6

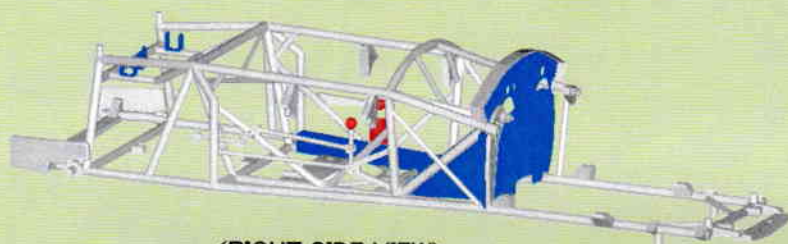
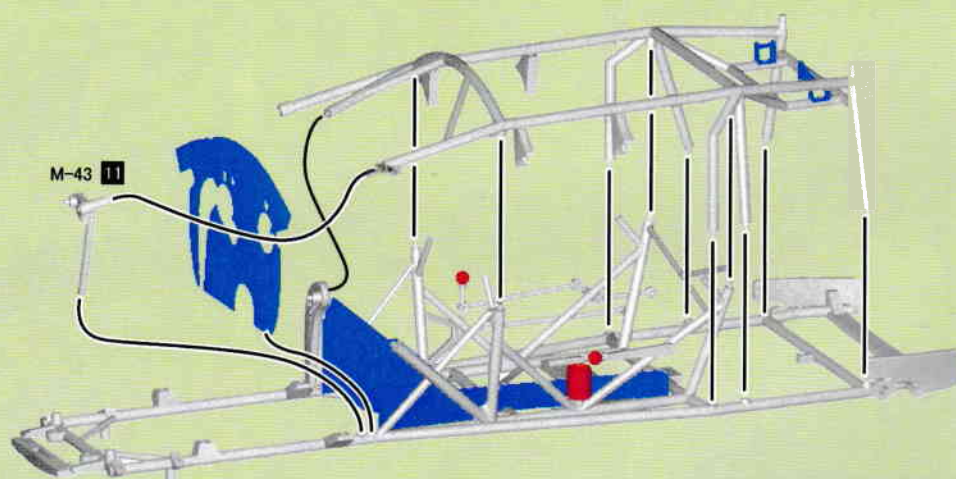

<RIGHT SIDE VIEW>



<LEFT SIDE VIEW>

★5 LEAF SPRING

2個ずつ作ります。
Make 2 each.

FRONT

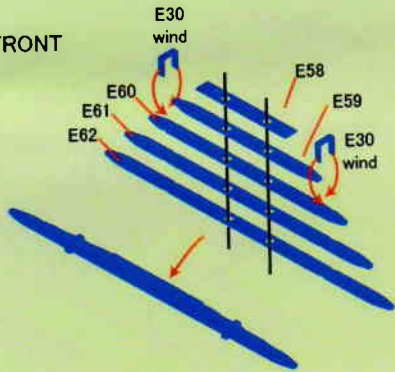

REAR

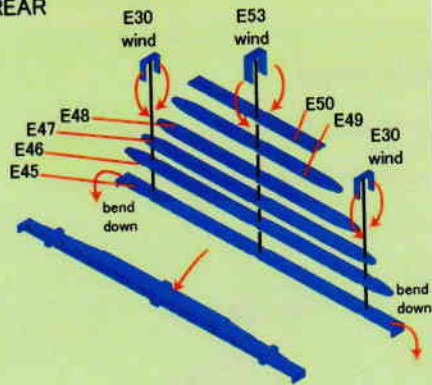

7

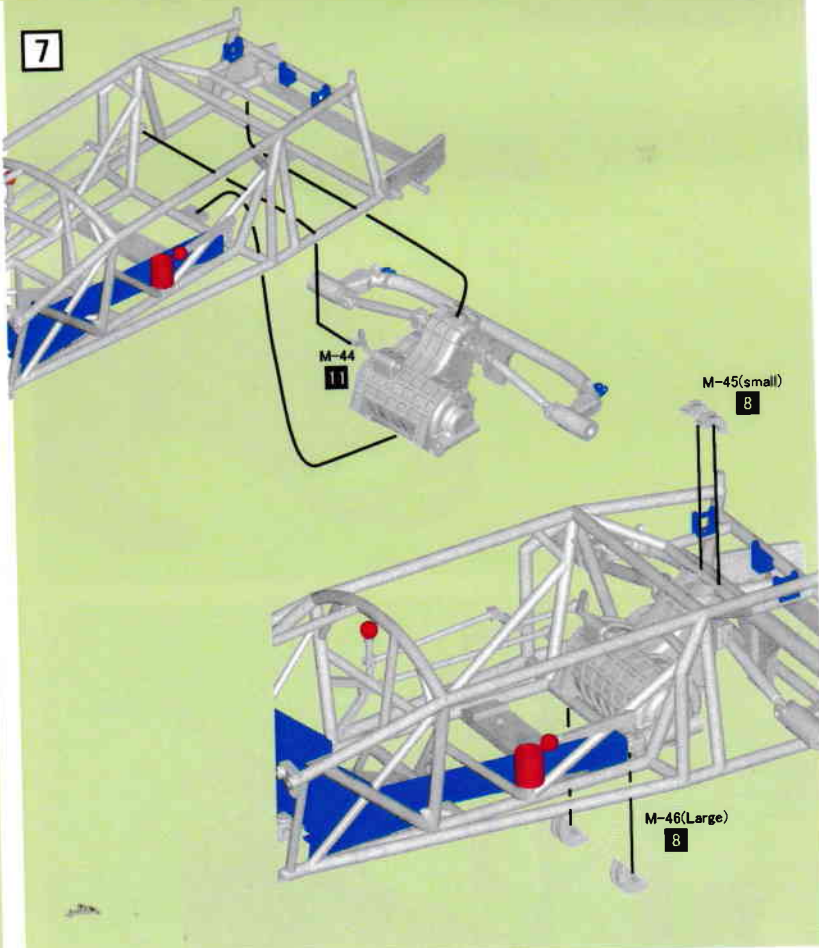

★6 RADIATOR

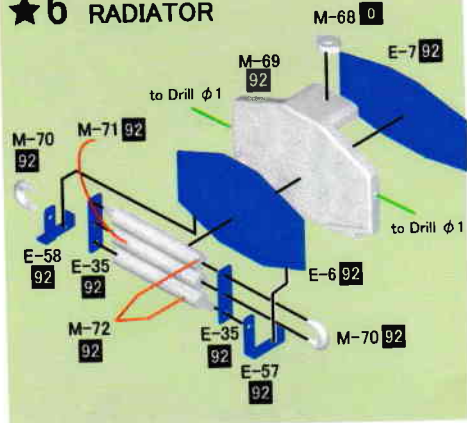

★7

Ⓑの溝にはまるよう成形してください。
adjust to fit the shape of ditch in Ⓑ.



8 REAR SUSPENSION

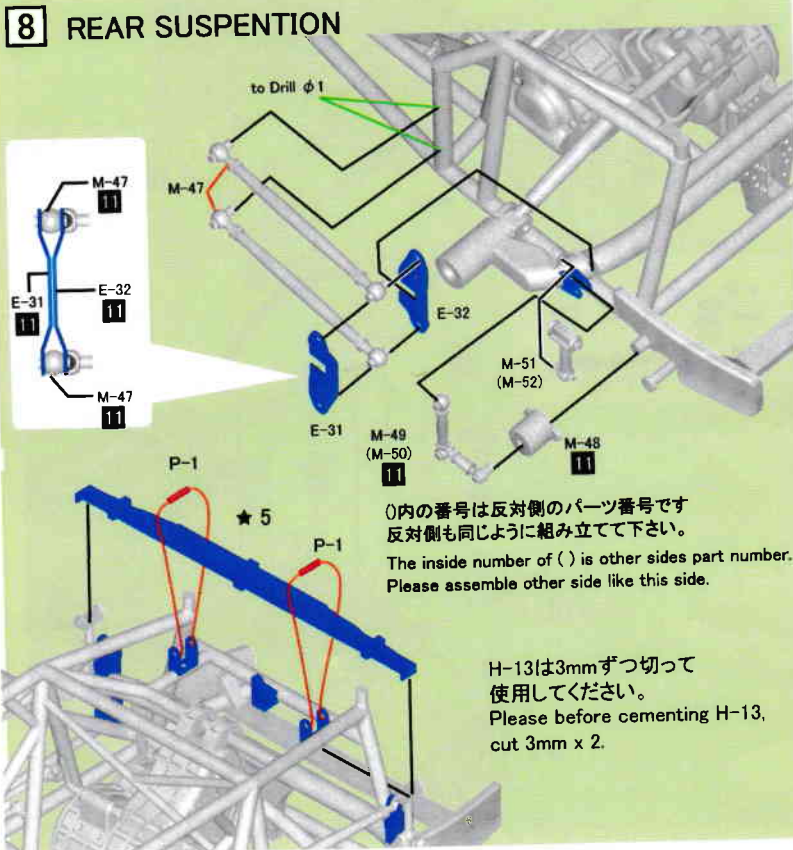

ⓐ内の番号は反対側のパーツ番号です
反対側も同じように組み立てて下さい。
The inside number of () is other sides part number.
Please assemble other side like this side.

H-13は3mmずつ切って
使用してください。
Please before cementing H-13,
cut 3mm x 2.

9 STEERING ROD

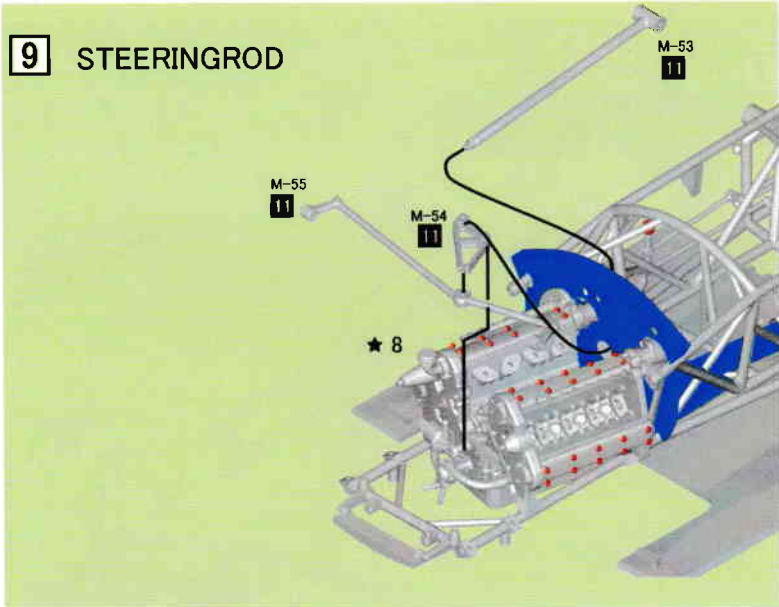

★ 8 FIXING ENGINE

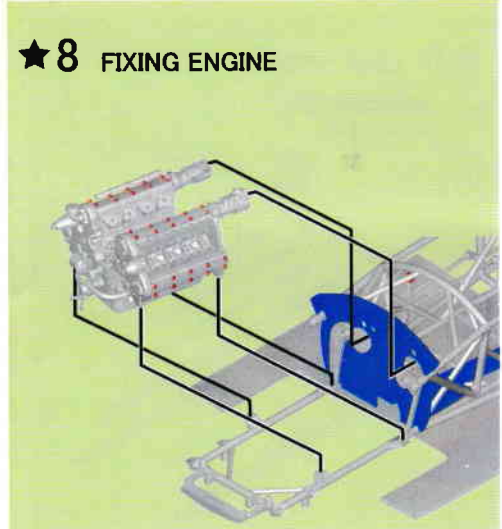

10 FRONT SUSPENTION

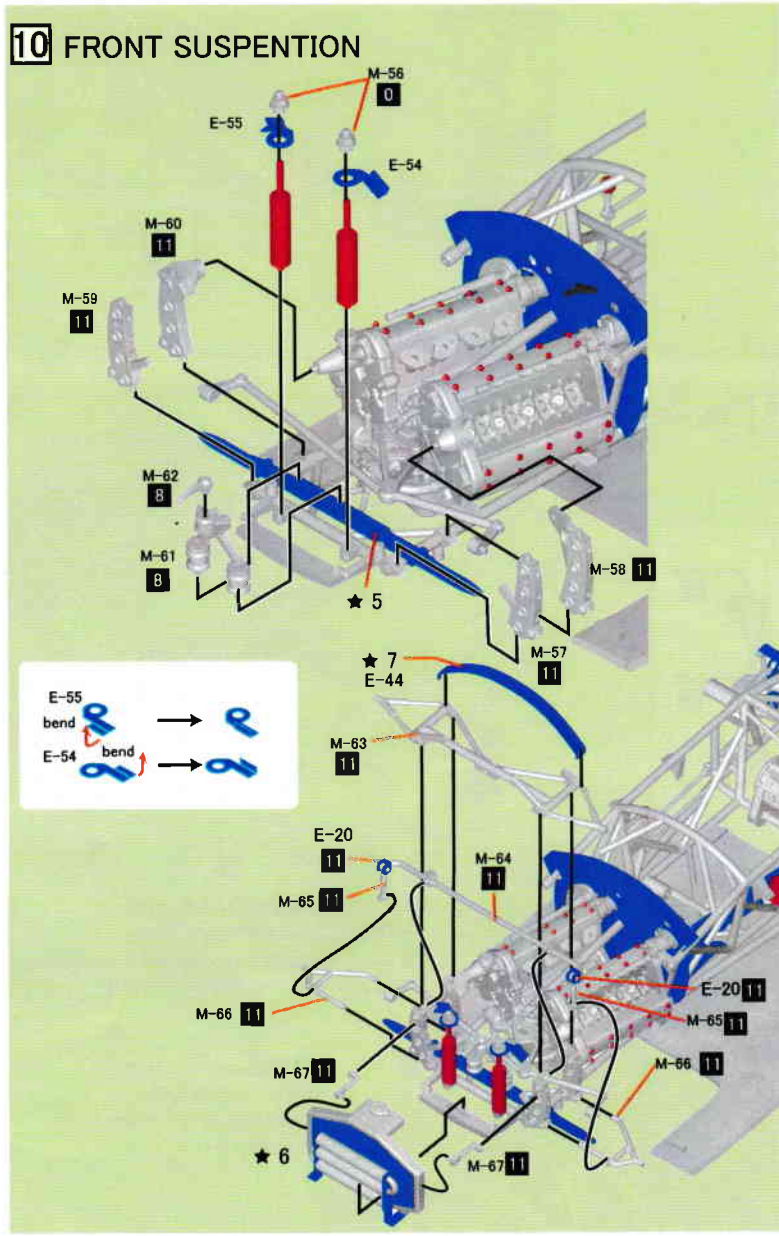

★ 9 PIPNG

P-2,P-3,P-4を図のようにエンジンに配線してください。
Insert P-2,P-3,P-4 into Engine as illustrated.

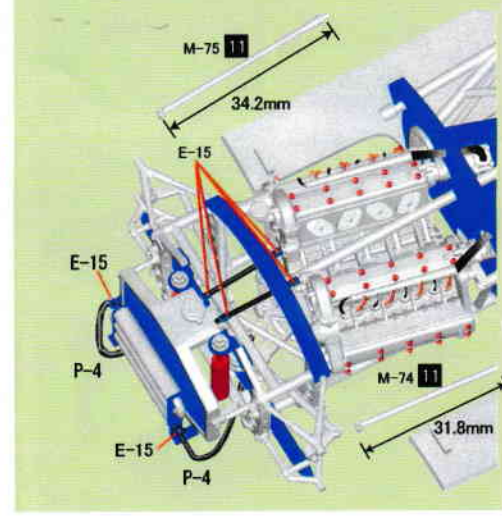
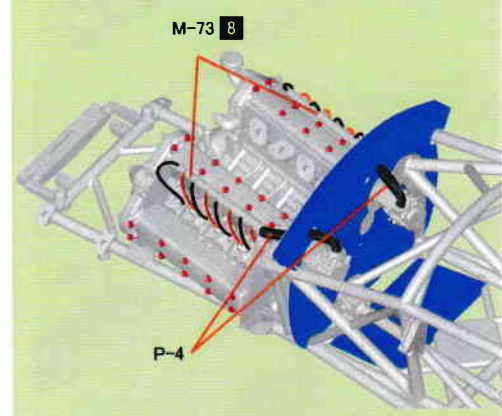

11

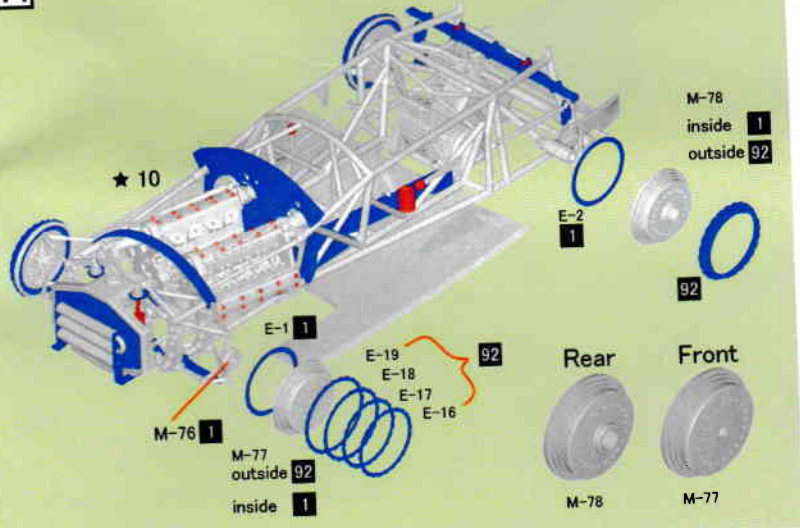

★ 10

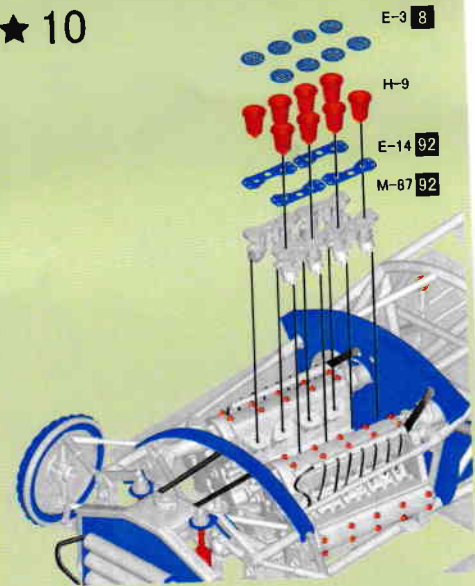

12

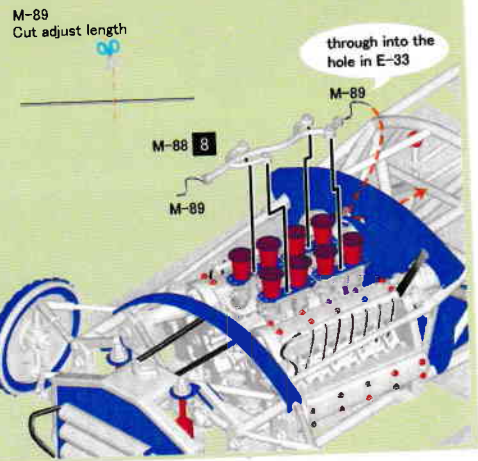
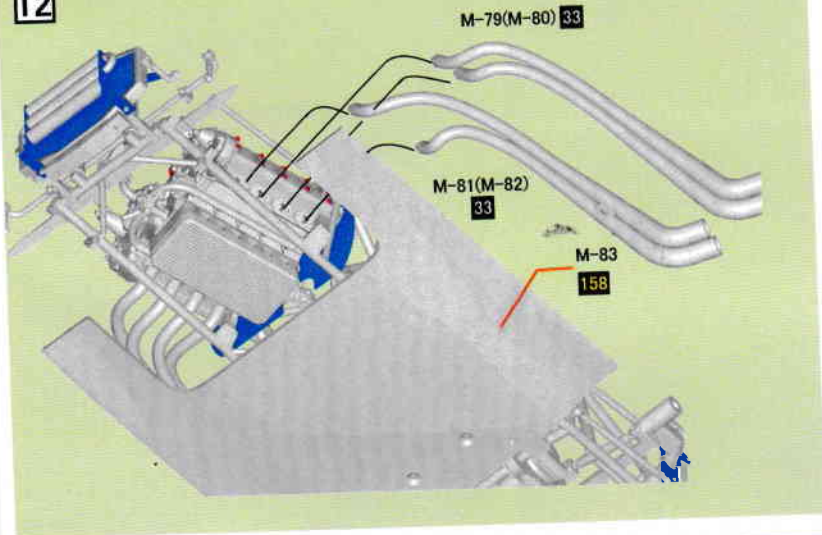

13

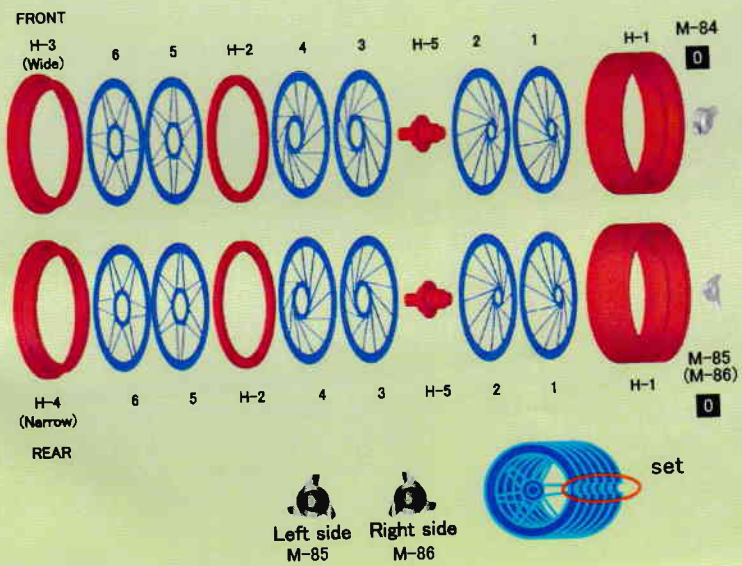

★ 11

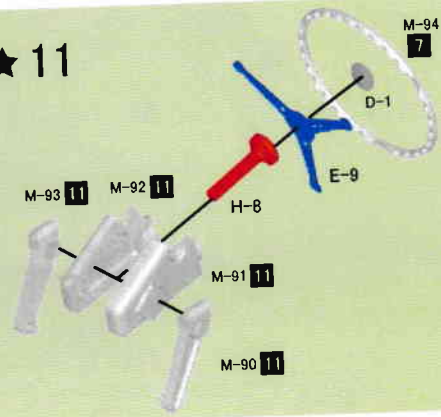

★ 12

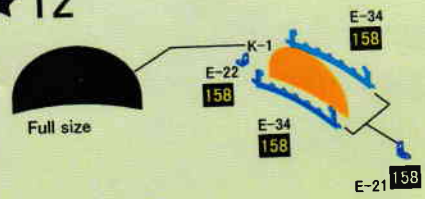

14

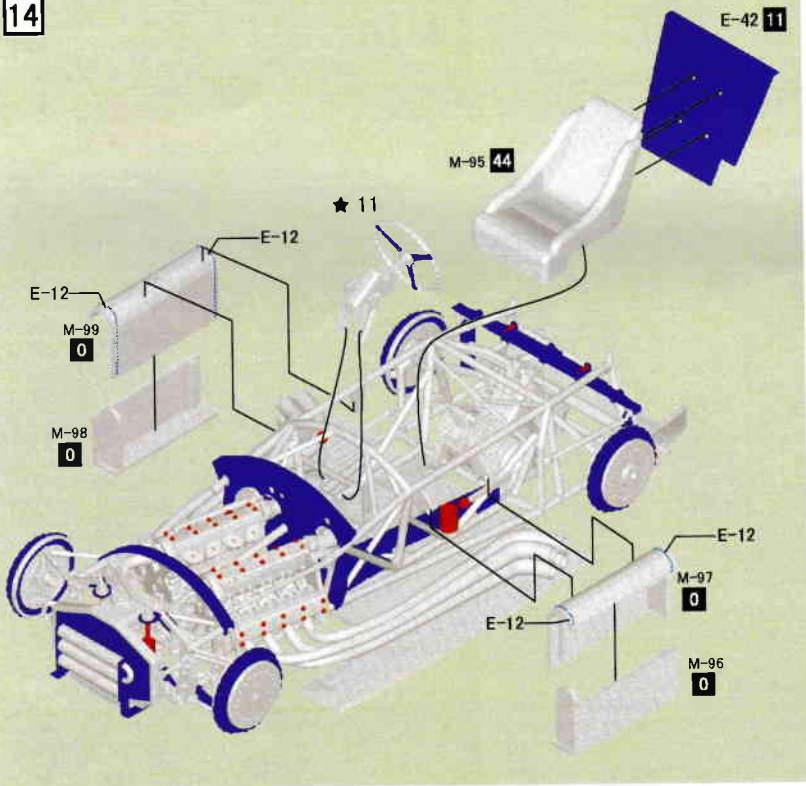

★ 13

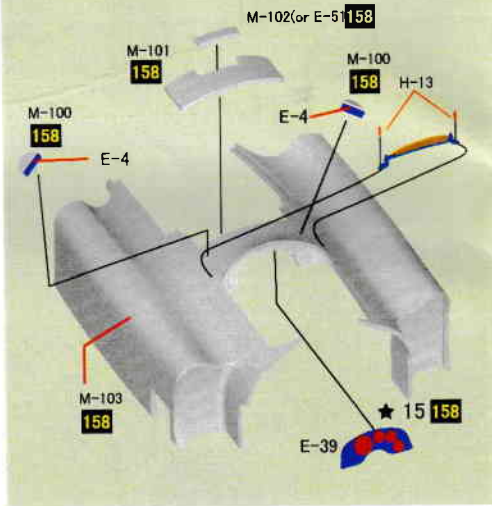

★ 14

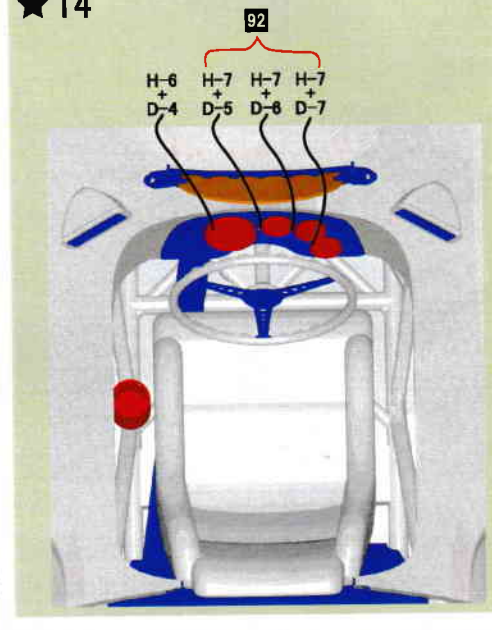

15

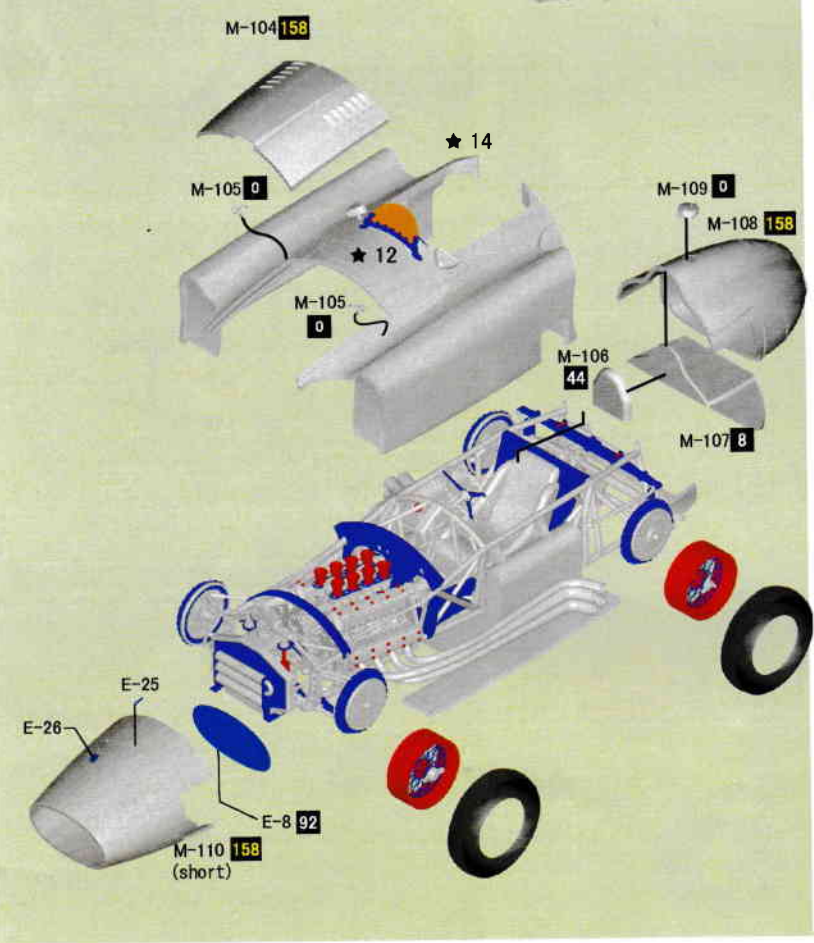

★ 15

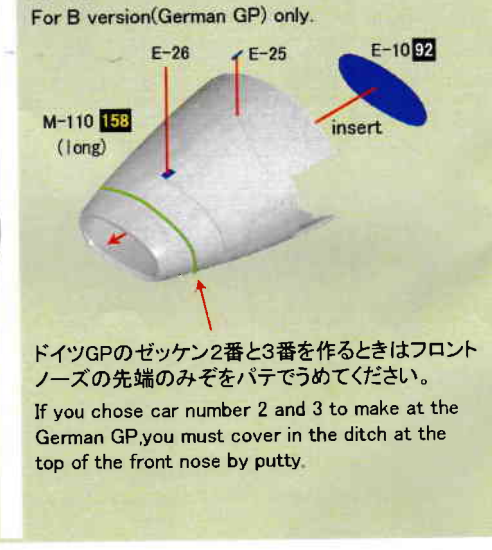

Applying Decals

type **A**

1956 ROUND2 MONACO GRAND PRIX

side view



a 番から i 番までのデカールはおまけです。
Decal number from a to i are extra parts.

top view

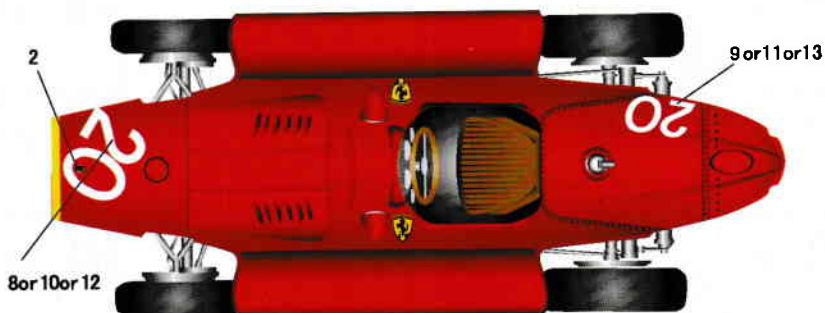

type **B**

1956 ROUND6 GERMAN GRAND PRIX

side view



a 番から i 番までのデカールはおまけです。
Decal number from a to i are extra parts.

top view



type **C**

1956 ROUND7 ITALIAN GRAND PRIX

side view



top view



a番から i番までのデカールはおまけです。
 Decal number from a to i are extra parts.
 D-17からD-25は使用しないでください。
 Do not use D-17 to D-25.

PRODUCTS NEWS

Ferrari 166MM/195S ¹⁹⁵⁰/₁₉₅₁

3月発売予定!

1/24 SCALE METAL KIT ¥25,000

Body of 195 is same size and shape as 166 but has minor detail differences - most noticeable being the grill, externally and the carbretor air clearers.

195Sport
A type

166MilleMiglia
B type

C type



Model Factory HIRO

5-22-23 Hokima, Adachi-ku, Tokyo 121-0064
 Phone: 81-5851-2522 Fax: 81-3-5851-2524

URL: <http://www.modelfactoryhiro.com>
 E-mail: cus@modelfactoryhiro.com