

4

Tokyo Marui Co., Ltd.

Use the tooth pick provided in the Kit when applying a small amount of bond.

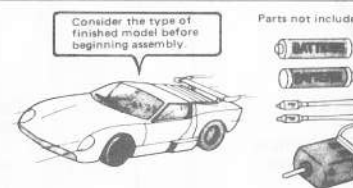
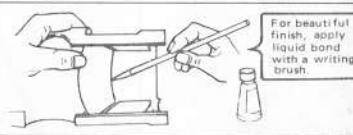

Remove burrs on parts using a cutter.
(Be careful not to cut your finger
with the cutter.)

Cut burrs and
unnecessary projected
portions.

For beautiful
finish, apply
liquid bond
with a writing
brush.

Paint parts for
real feeling.

Consider the type of
finished model before
beginning assembly.

Parts not included:

Bond provided in the Kit may be
used, but purchase liquid bond if
beautiful finish is desired. Apply
bond to both contact faces.

Some painting instructions are in-
cluded in this instruction sheet.
See picture on the packaging as a
reference. (Purchase lacquer or enamel
for plastic use.)

If so desired, head and tail lights may be
illuminated. Purchase two or four
small lamps. (2.5 to 3V)
Those planning to motorize this model must
purchase separately the Mabuchi FA-130
motor and 2UM-3(AA) batteries.

Glue the part into
the groove.

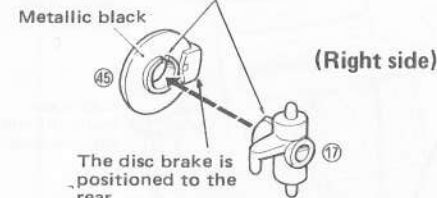

The disc brake is
positioned to the
rear.

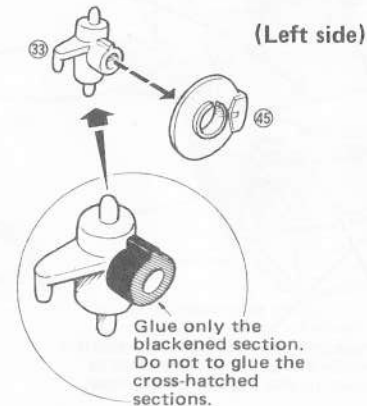

Position
the grooved
section to
the front.

6 Rear wheel assembly

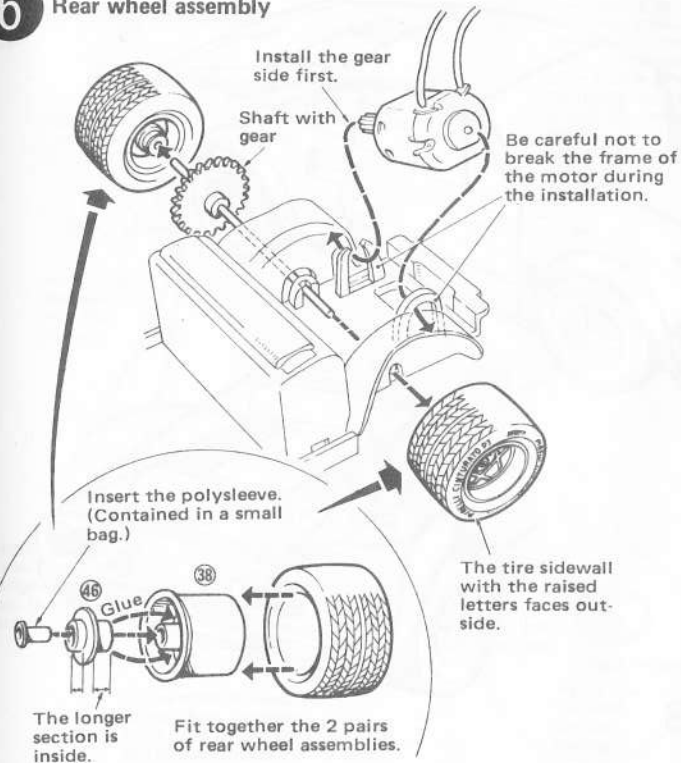

7 Battery box assembly

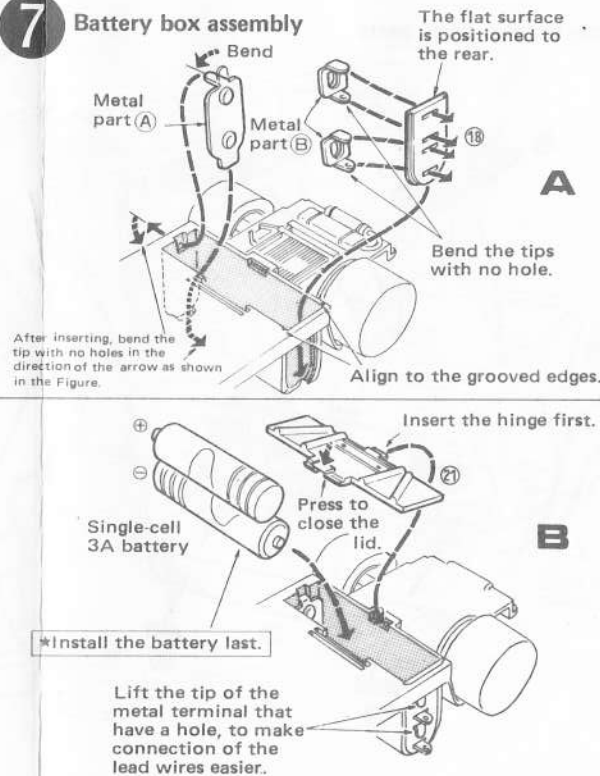

8 Wiring procedures

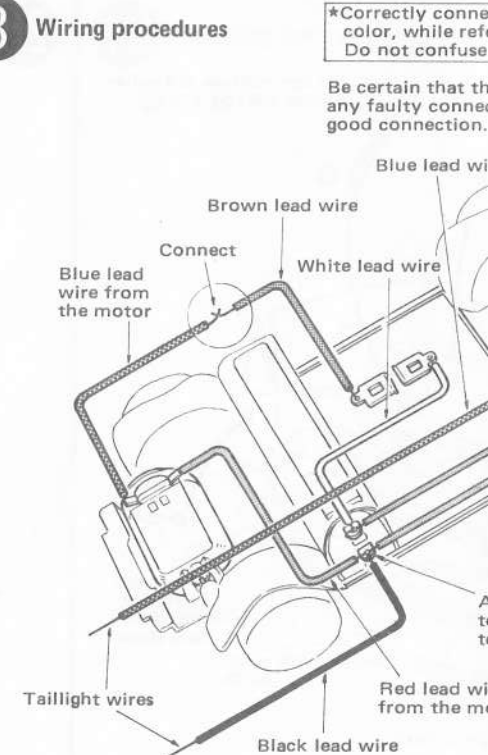

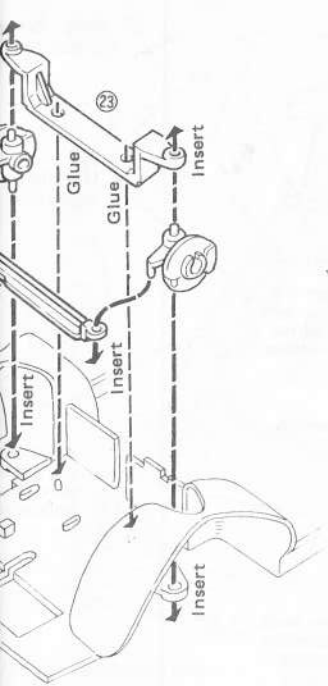

Adding grease designed for plastic parts to the shank of the screw improves wheel rotation.

Tighten the screw with a small bladed screwdriver of the correct size.

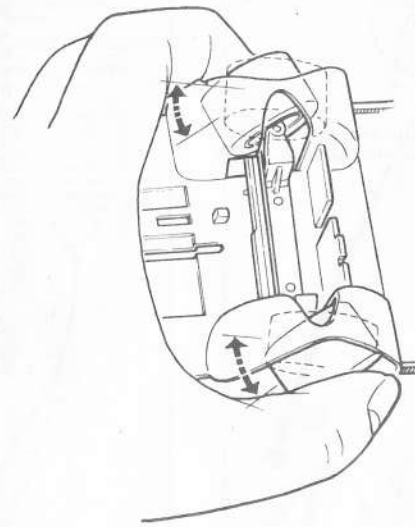
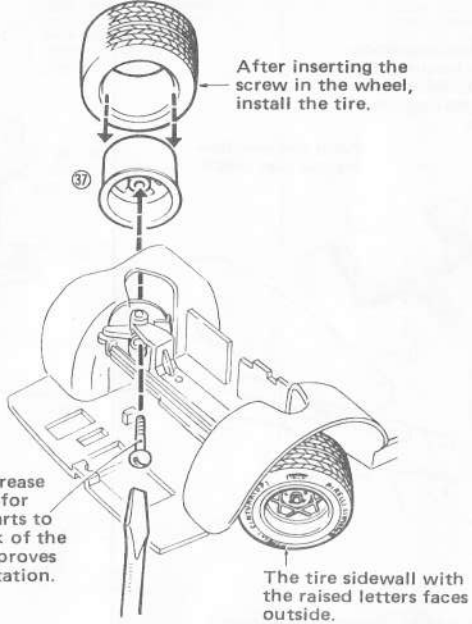

To turn the both front wheels, move the wheels by holding on both tires with your fingers as shown in the Figure.

Tap with a small hammer to drive the gear onto the motor shaft.

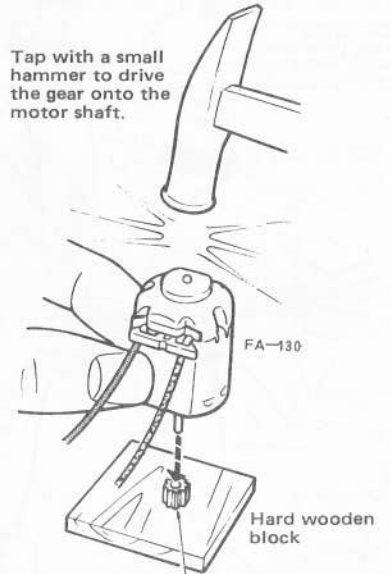

Drive the pinion gear onto the motor shaft until the outer surface of the gear is even with the end of the shaft.

Connect the wires according to their colors to the wiring diagram below. Soldering will ensure a

firmly secured without

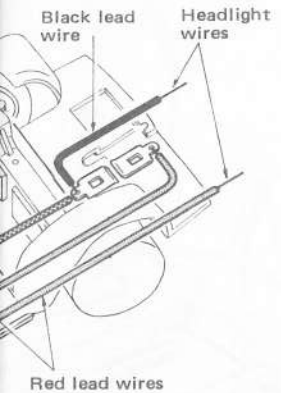

When connecting the lead wires to the terminals of the battery box, bend the terminals down.

9 Installing the wires and the switch metal parts

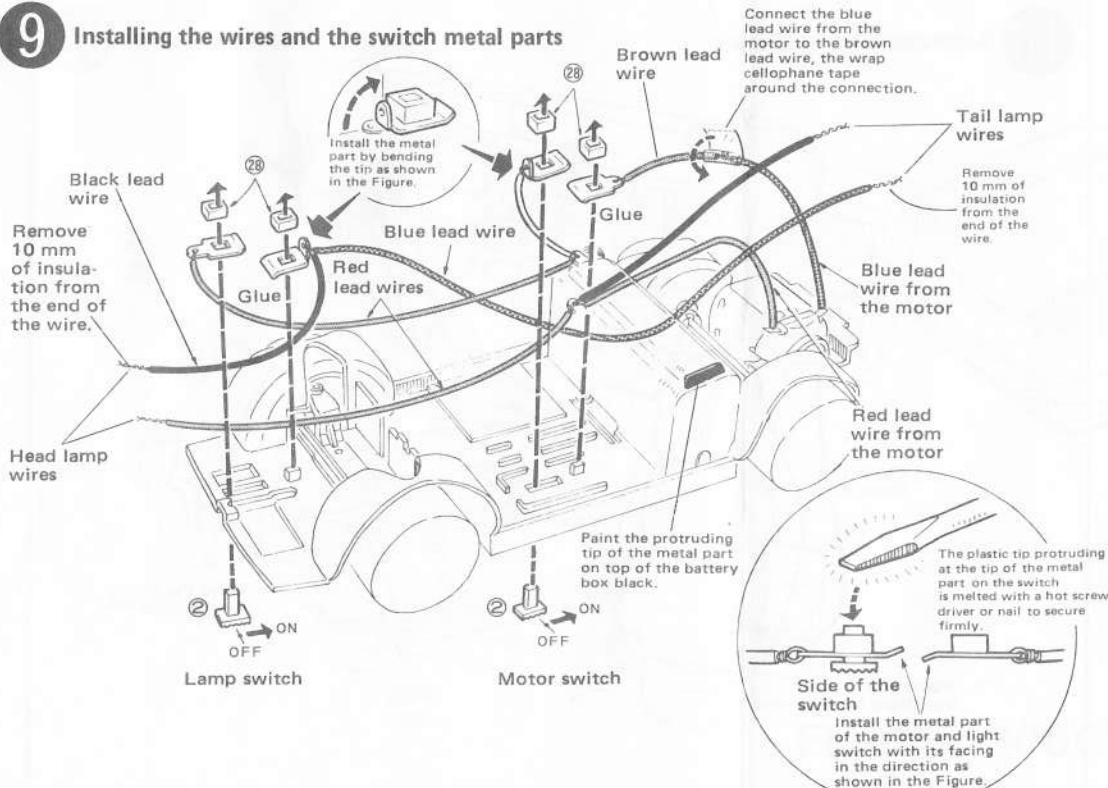

10 Installing the seatbelt

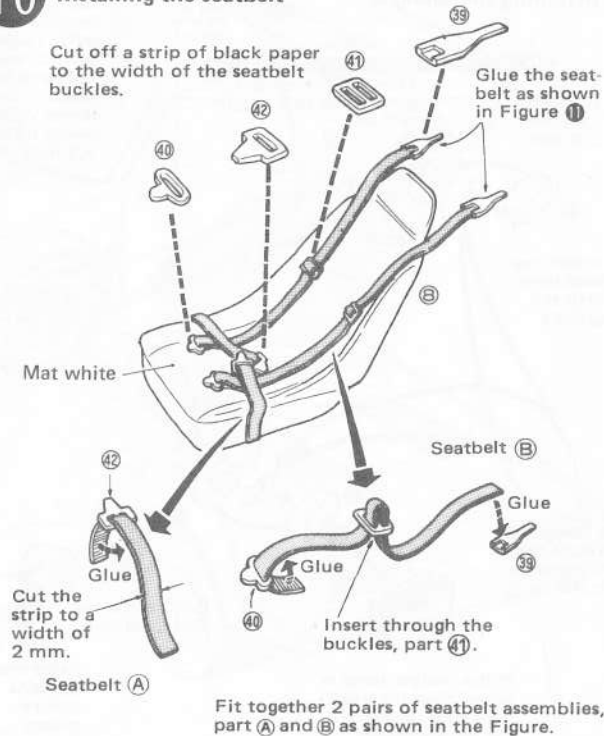

*Gather the lead wires into the groove of part 13, then glue in position.

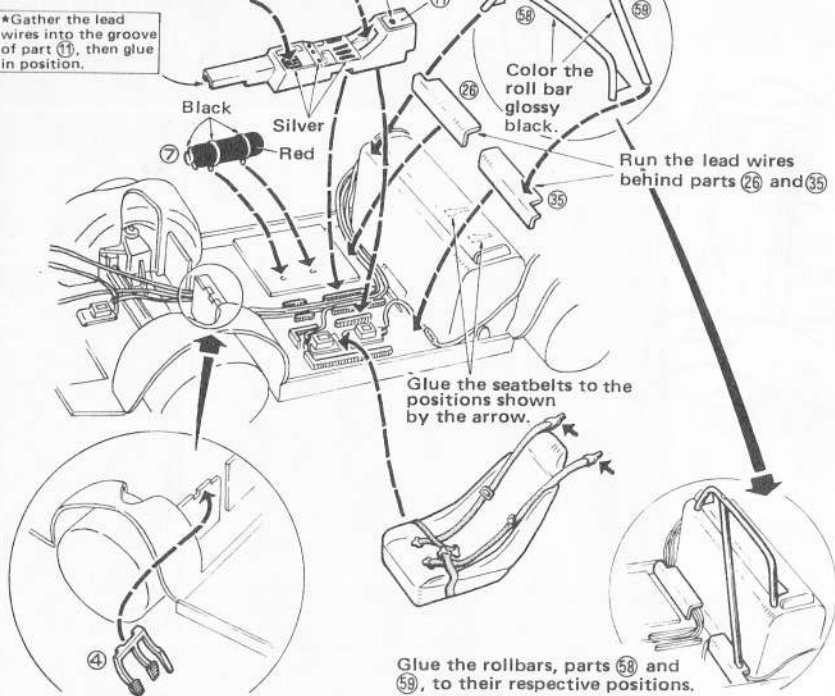

Remove the plastic sections as they will not be used. Do not scratch the body with the cutter when removing the plastic sections.

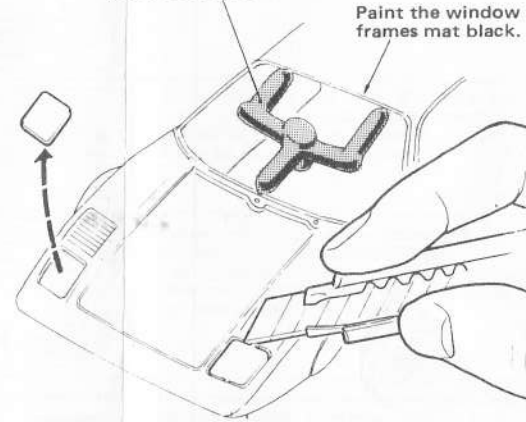

* Cut out the parts neatly. Remove any rough spots. It is not necessary to remove the part for those not planning to install headlights.

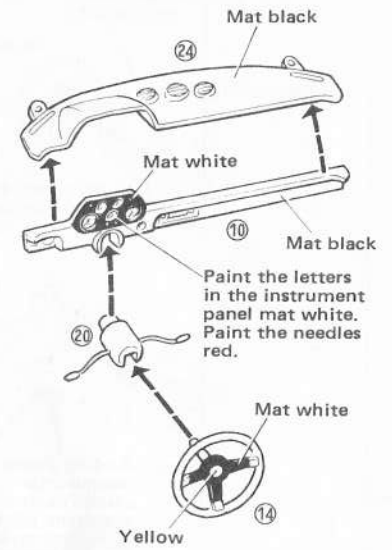

How to make mat white: Mix a small amount of silver into the white paint, then add the flat base material to make the paint mat.

17 Installing the taillight

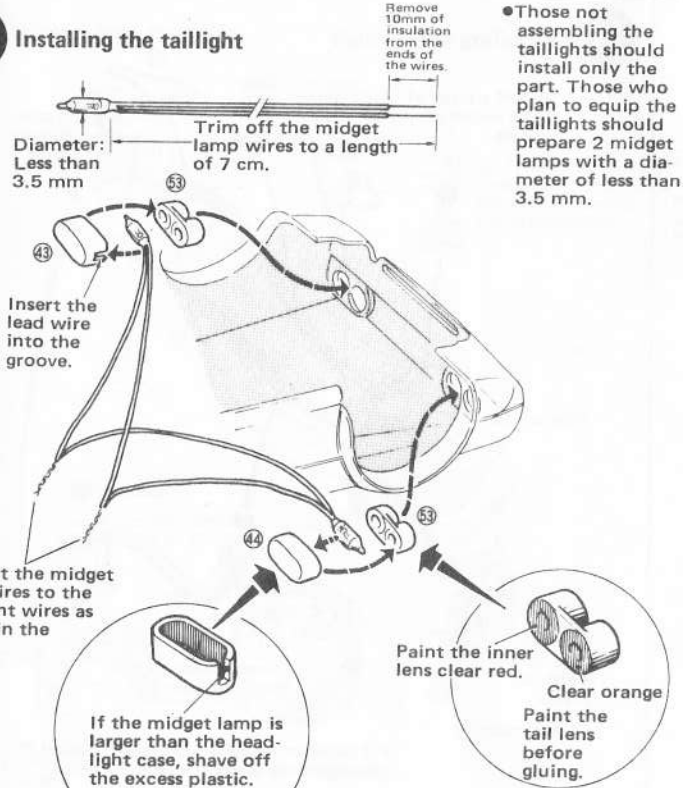

• Those not assembling the taillights should install only the part. Those who plan to equip the taillights should prepare 2 midget lamps with a diameter of less than 3.5 mm.

18 Body and chassis assembly

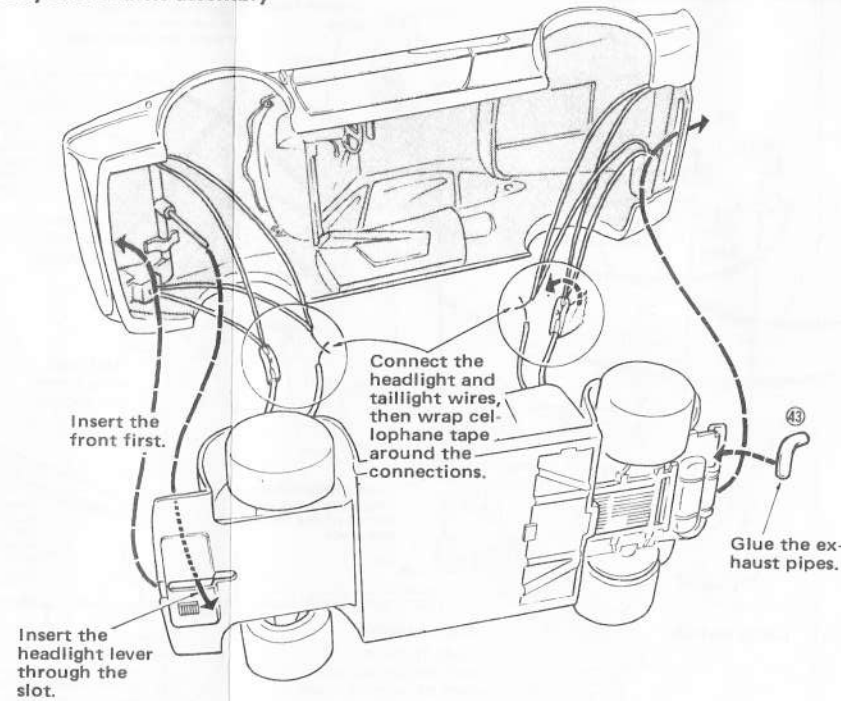

19 Installing the front body part

