

Ver. A

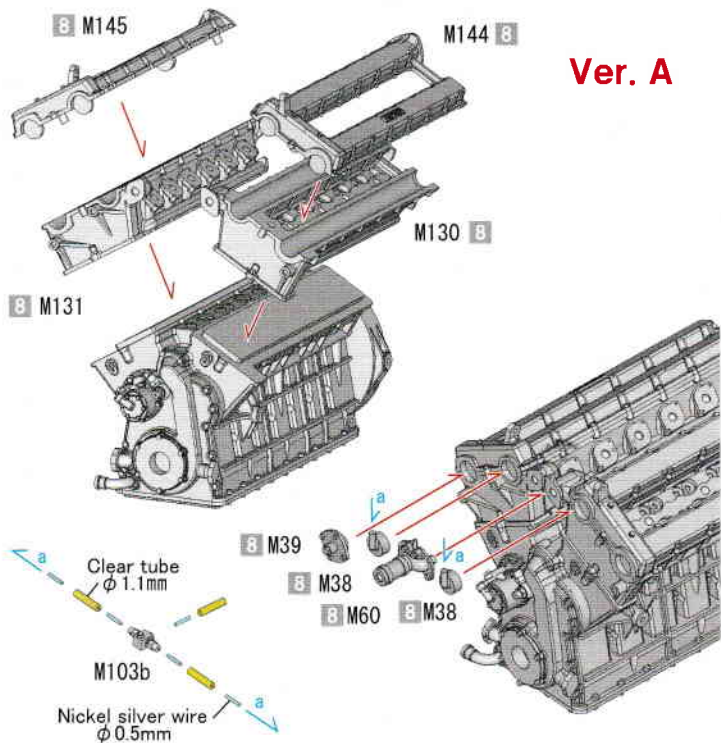

Ver. B

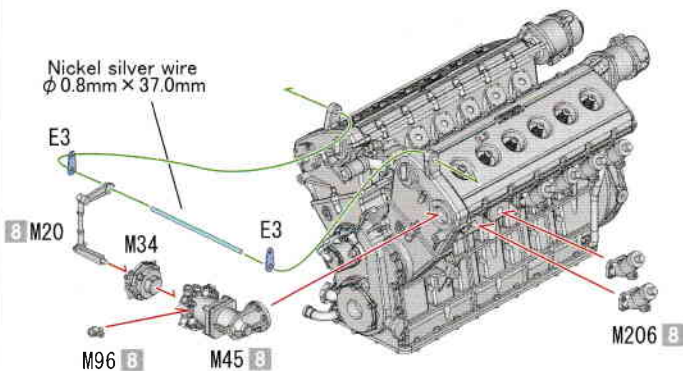
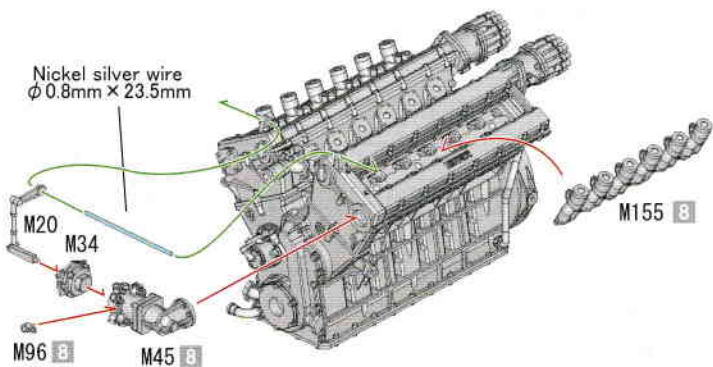
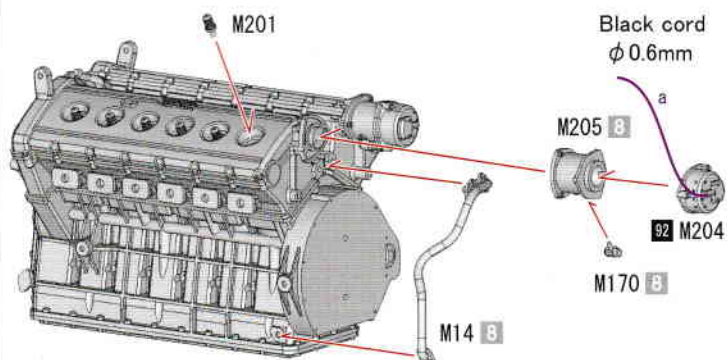
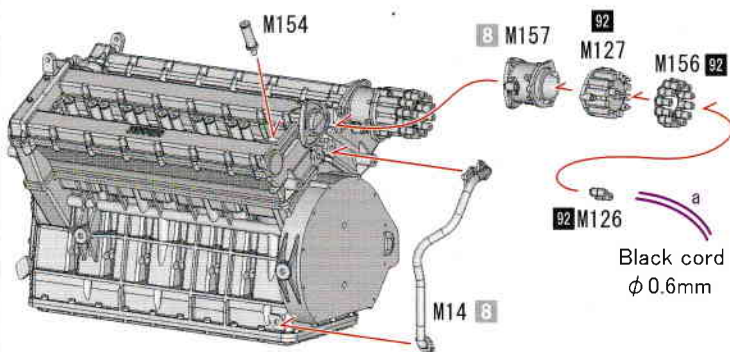
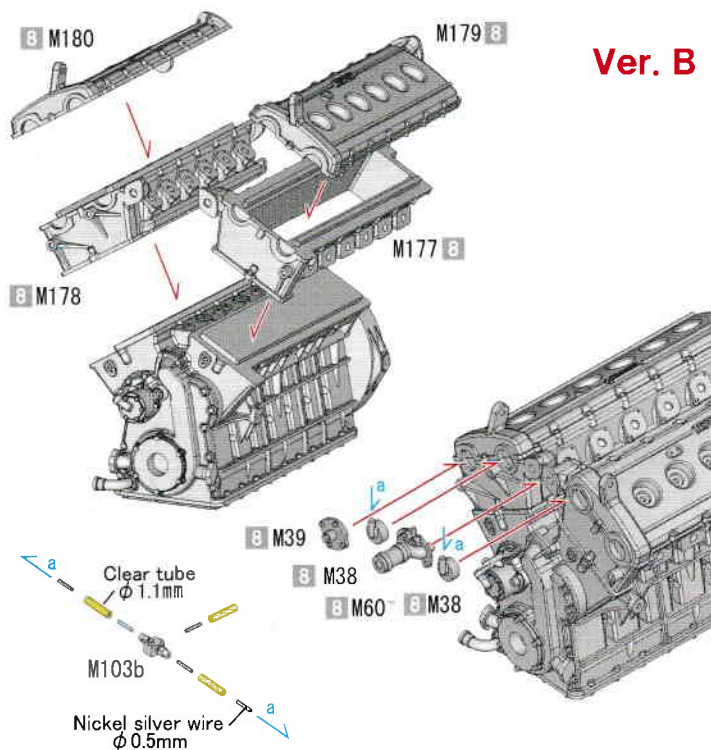

Please assemble both sides also as shown.
反対側も同様に取付けます。

Please assemble both sides also as shown.
反対側も同様に取付けます。

< Piping >

Stretch
 $\phi 1.25\text{mm}$
 Clear tube

$\phi 0.7\text{mm}$
 about

Black cord $\phi 0.6\text{mm}$
 Clear tube $\phi 0.7\text{mm}$

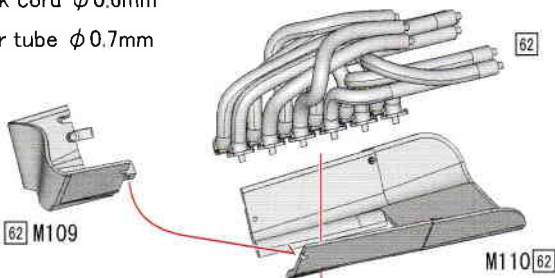
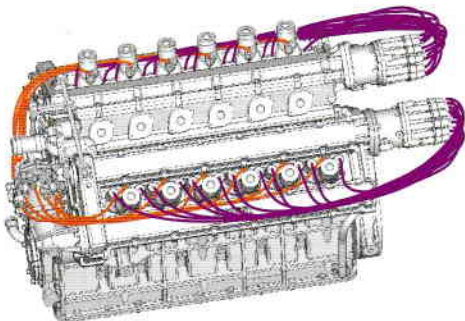

図の様に取付けます。
 Please assemble as shown.

原寸大
 Actual size

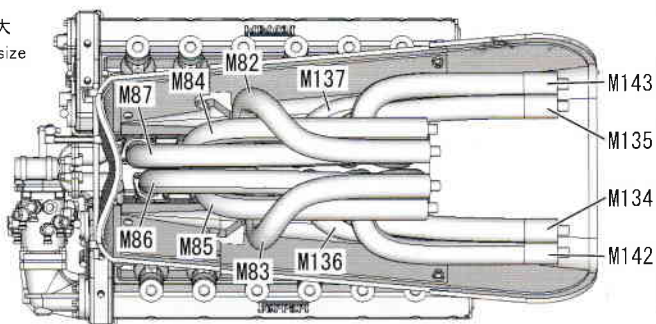

< Piping >

Stretch
 $\phi 1.25\text{mm}$
 Clear tube

$\phi 0.7\text{mm}$
 about

Black cord $\phi 0.6\text{mm}$
 Clear tube $\phi 0.7\text{mm}$

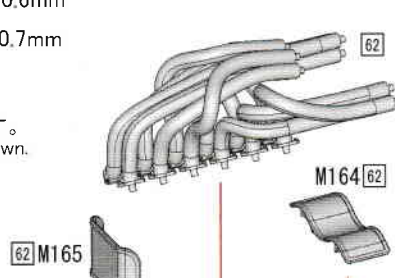
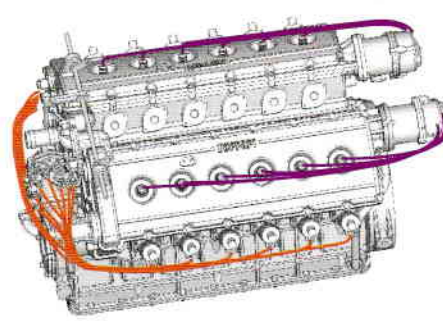

図の様に取付けます。
 Please assemble as shown.

原寸大
 Actual size

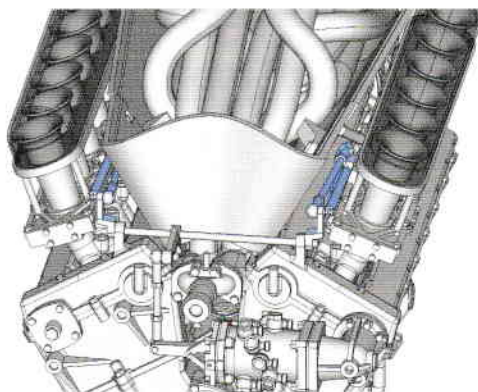
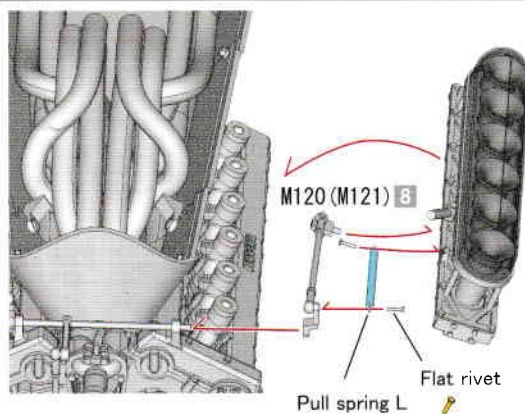
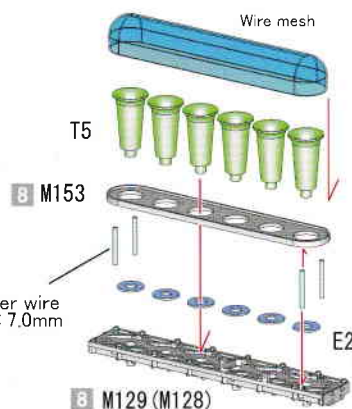
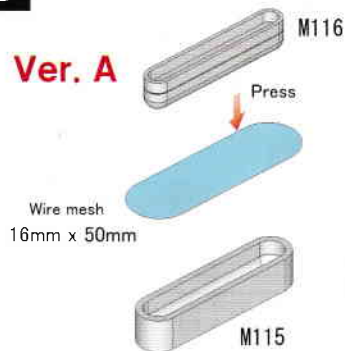
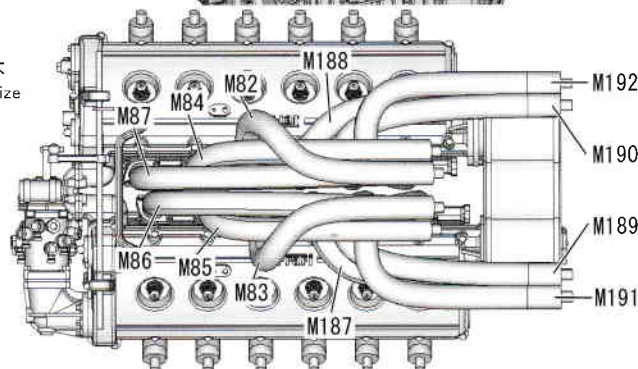

図の様に取付けます。
 Please assemble as shown.

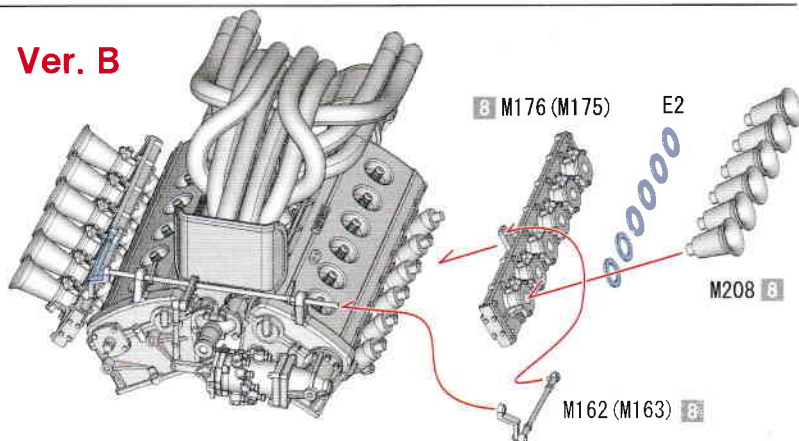

反対側も同様に取付けます。
 Please assemble both sides also as shown.

4

Ver. A

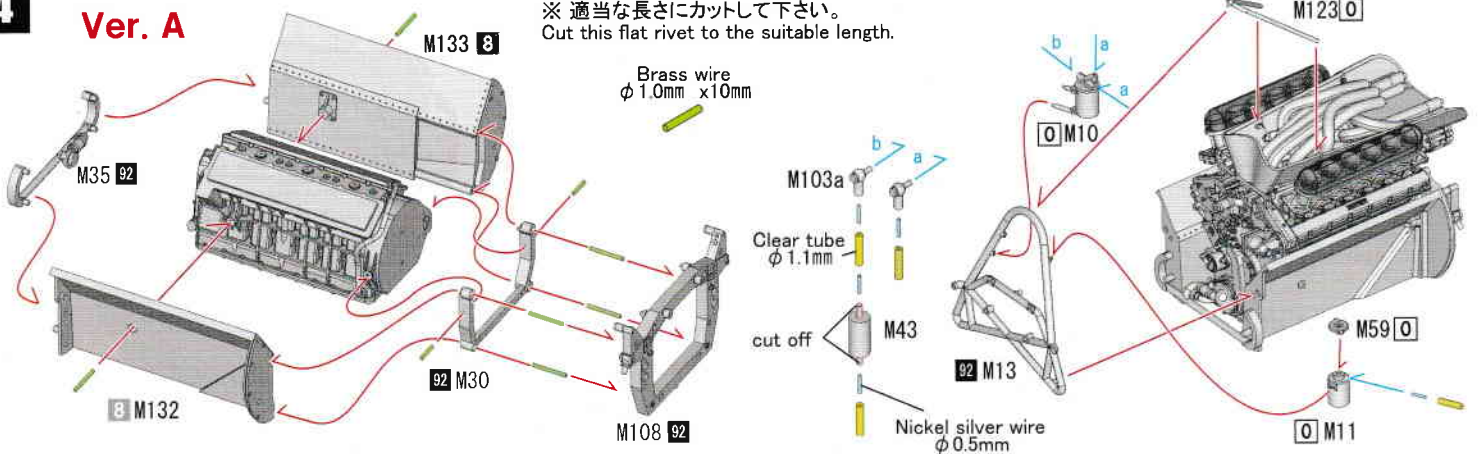

Ver. B

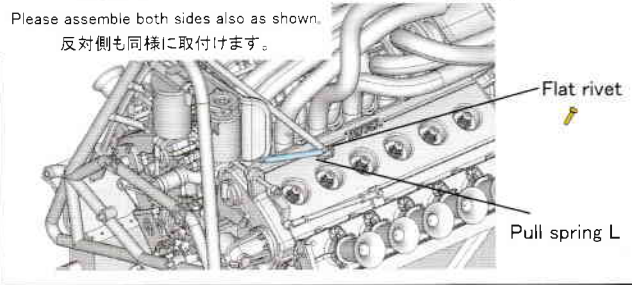
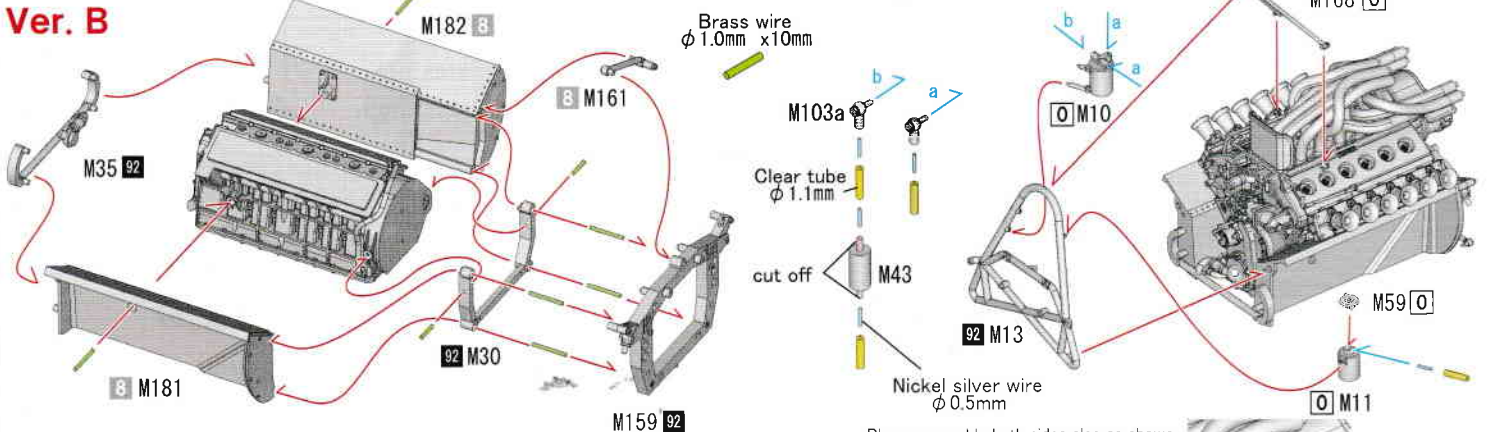

5

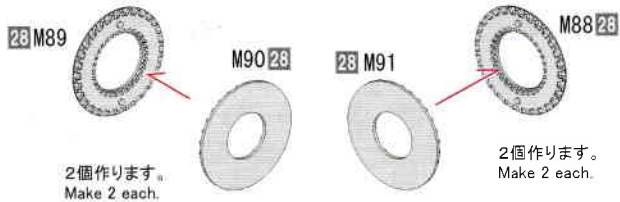

Ver. A

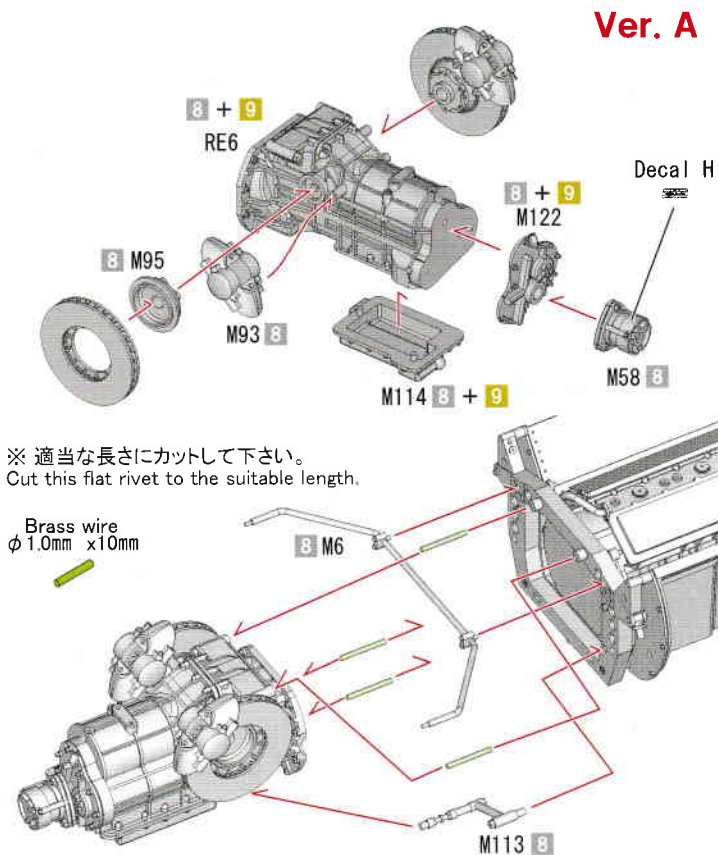

Ver. B

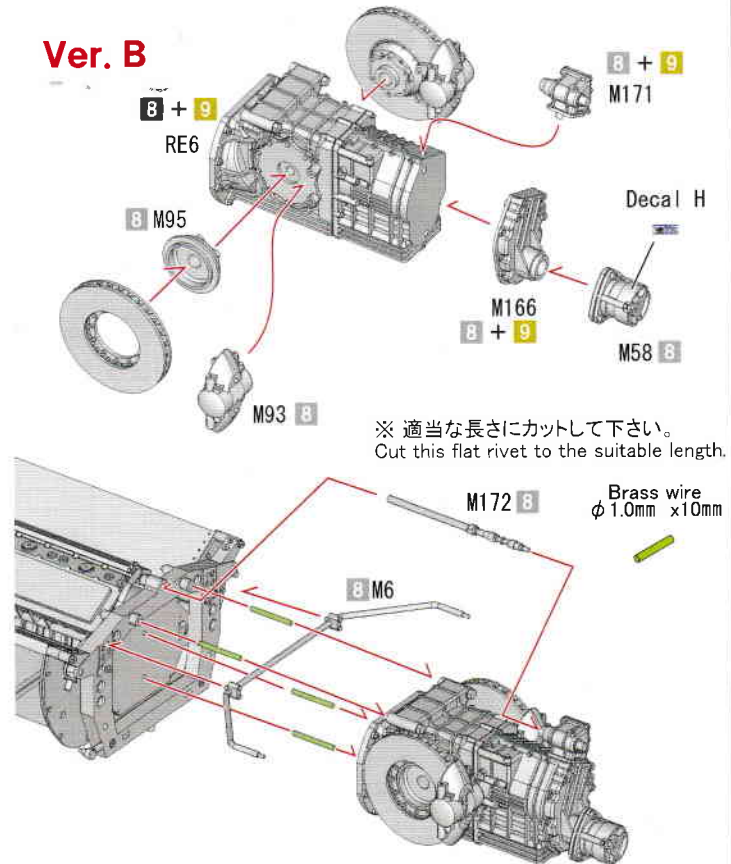

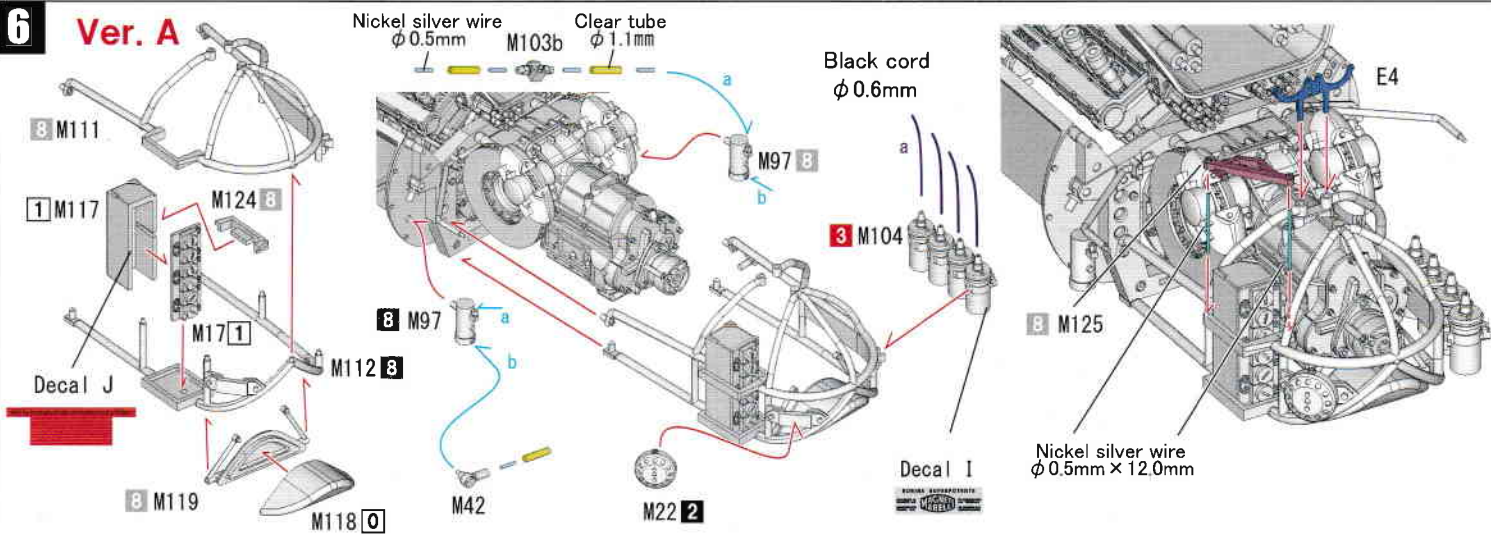
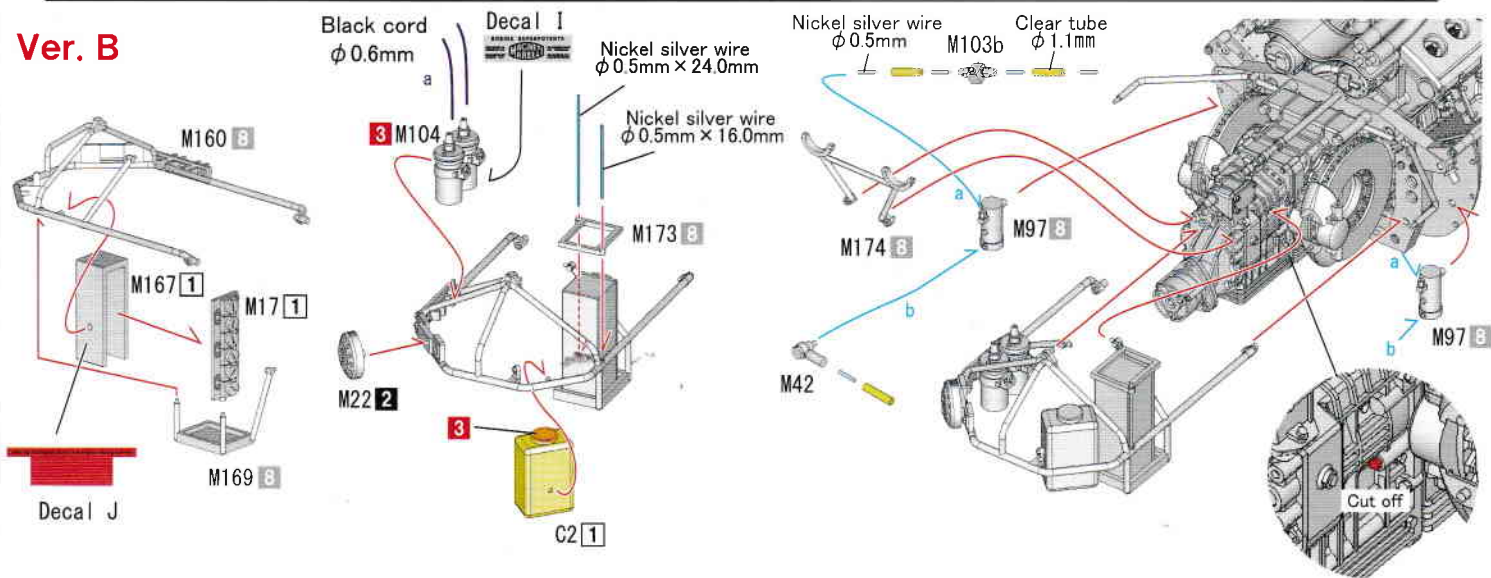
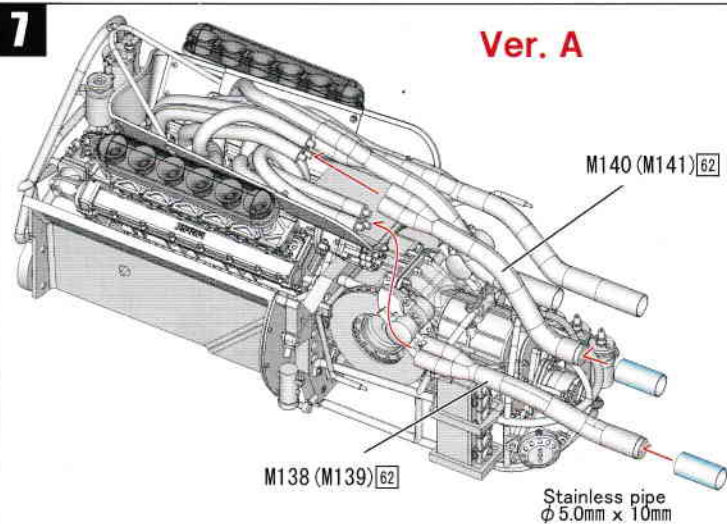
6**Ver. A****Ver. B****7****Ver. A**

反対側も同様に取付けます。
Please assemble both sides also as shown.

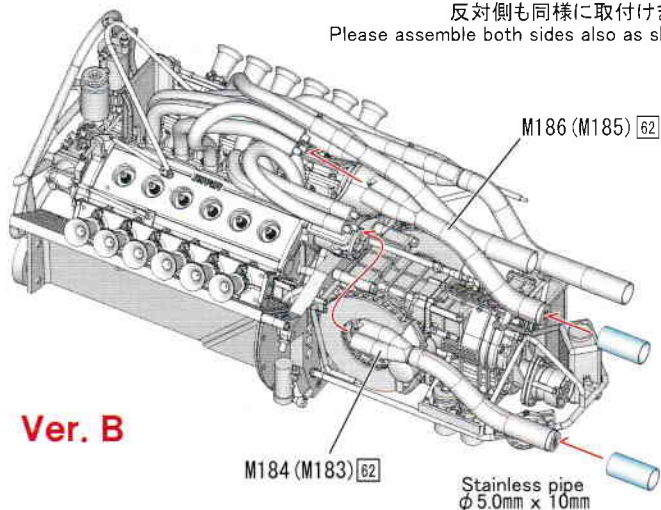
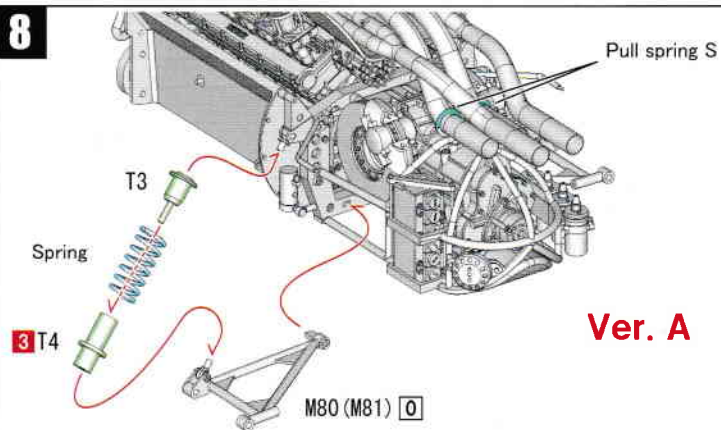
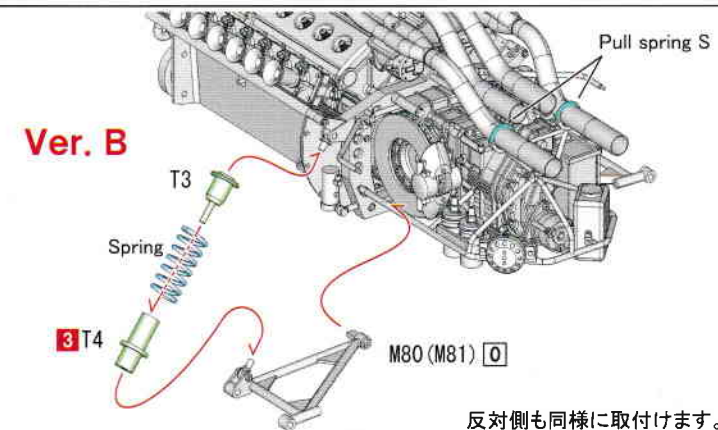
**8****Ver. A****Ver. B**

反対側も同様に取付けます。
Please assemble both sides also as shown.

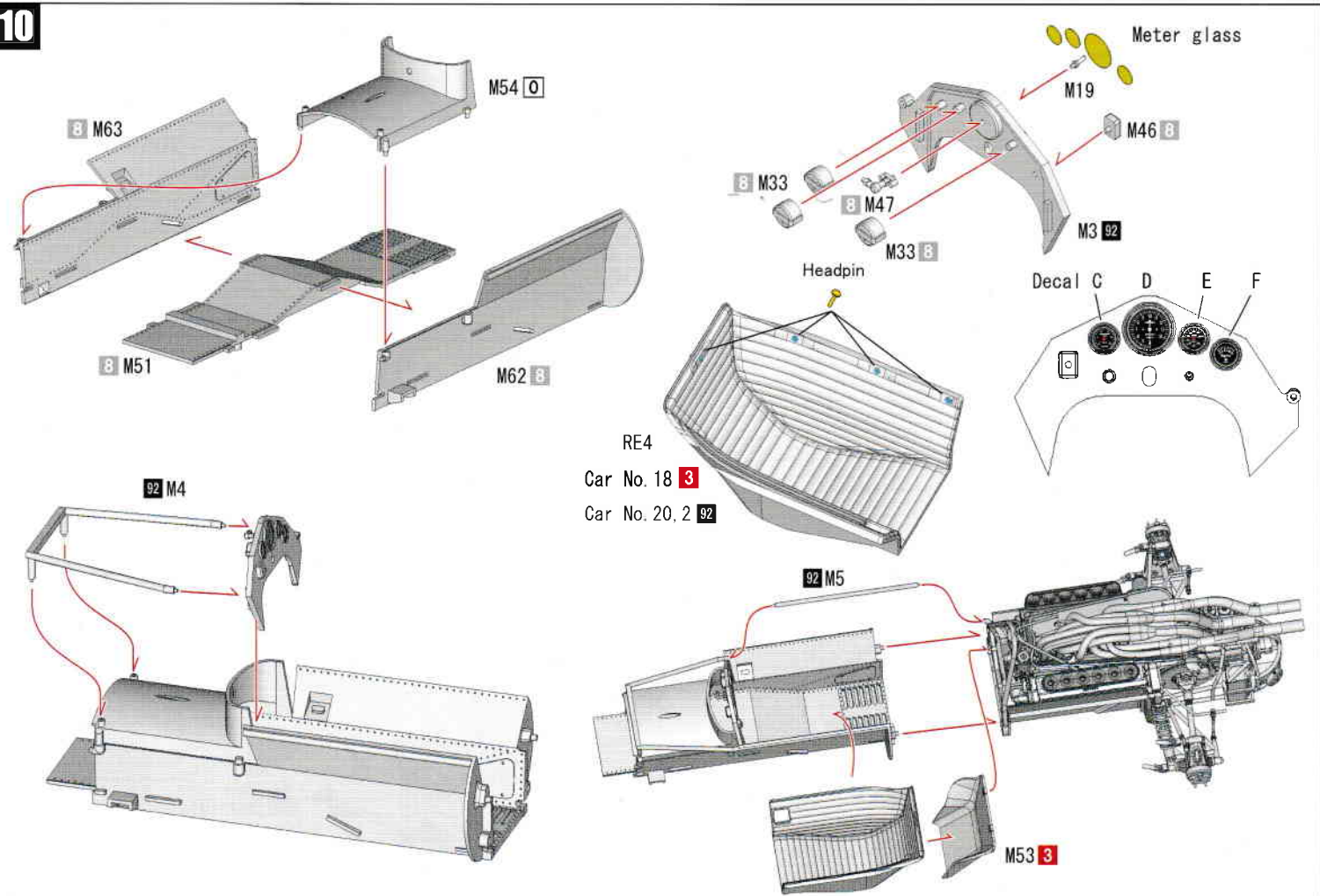
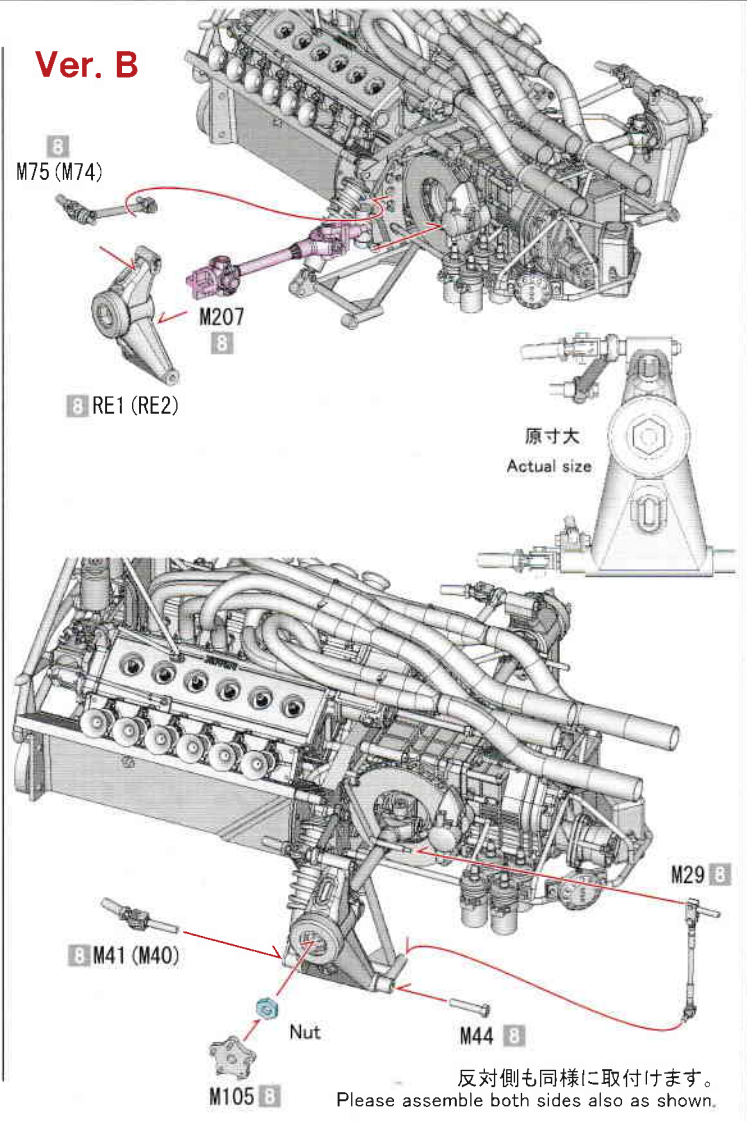
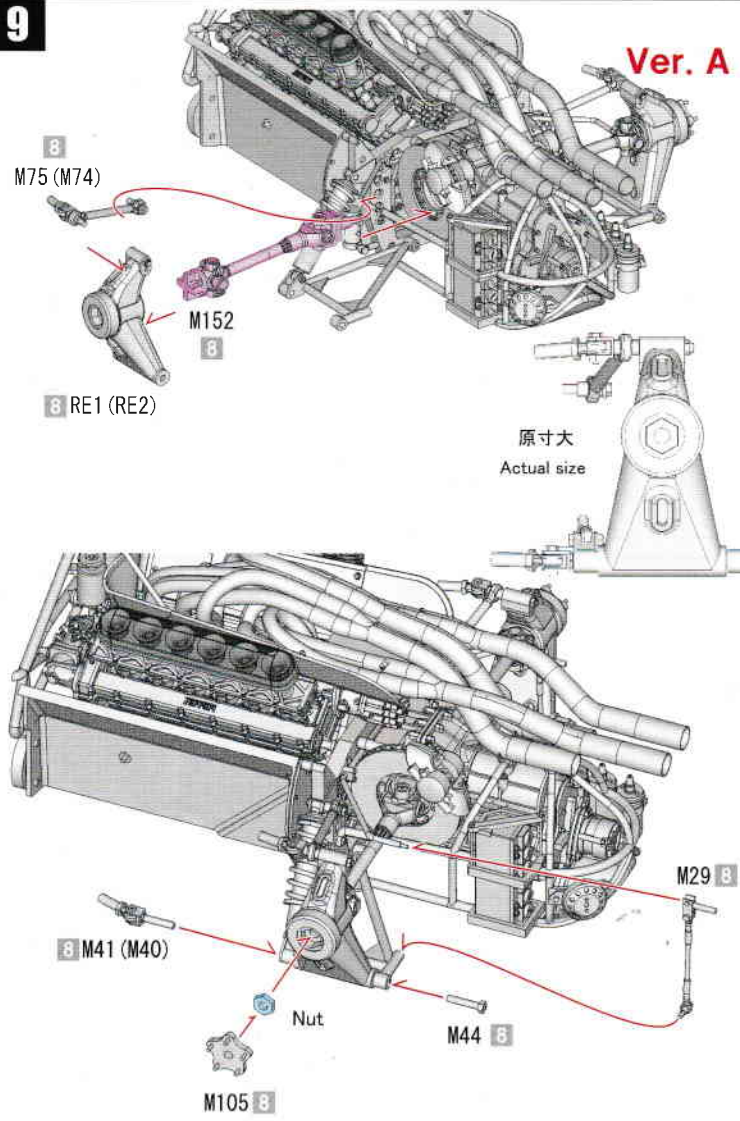

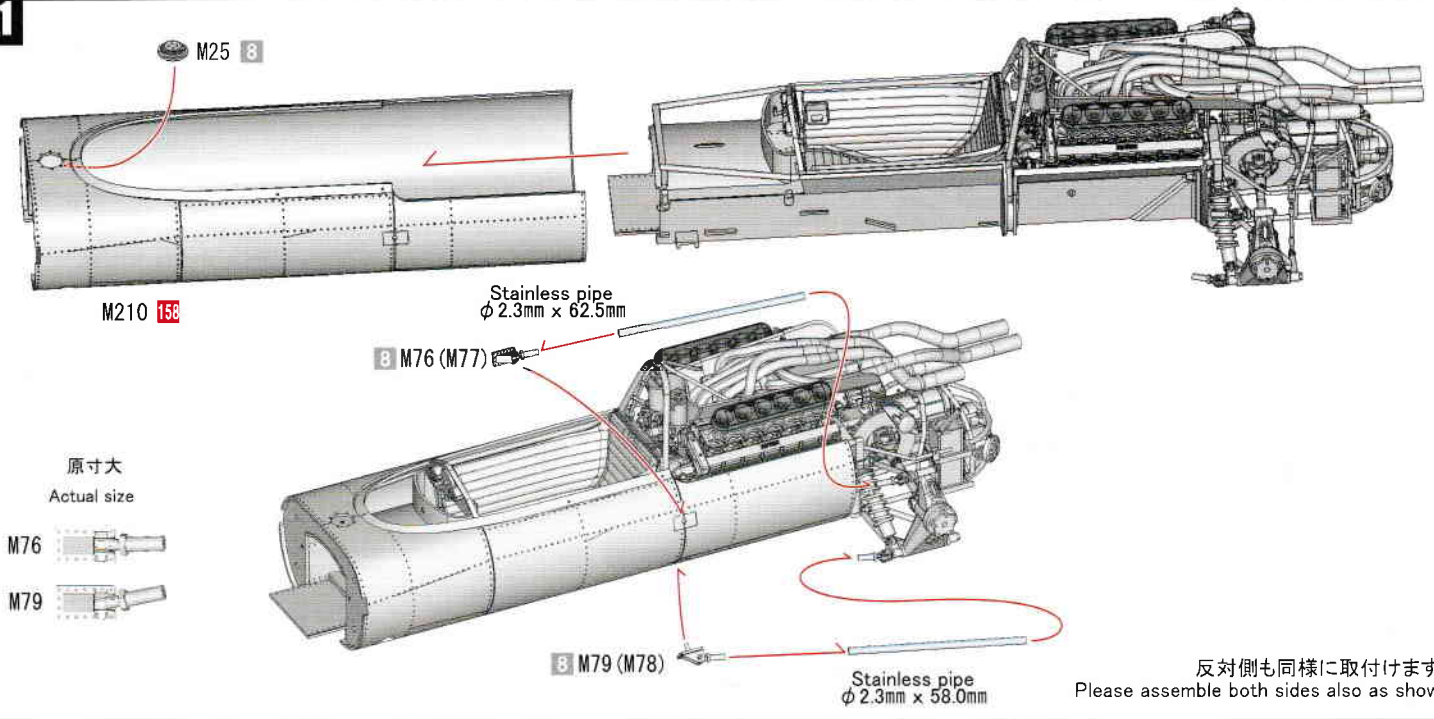
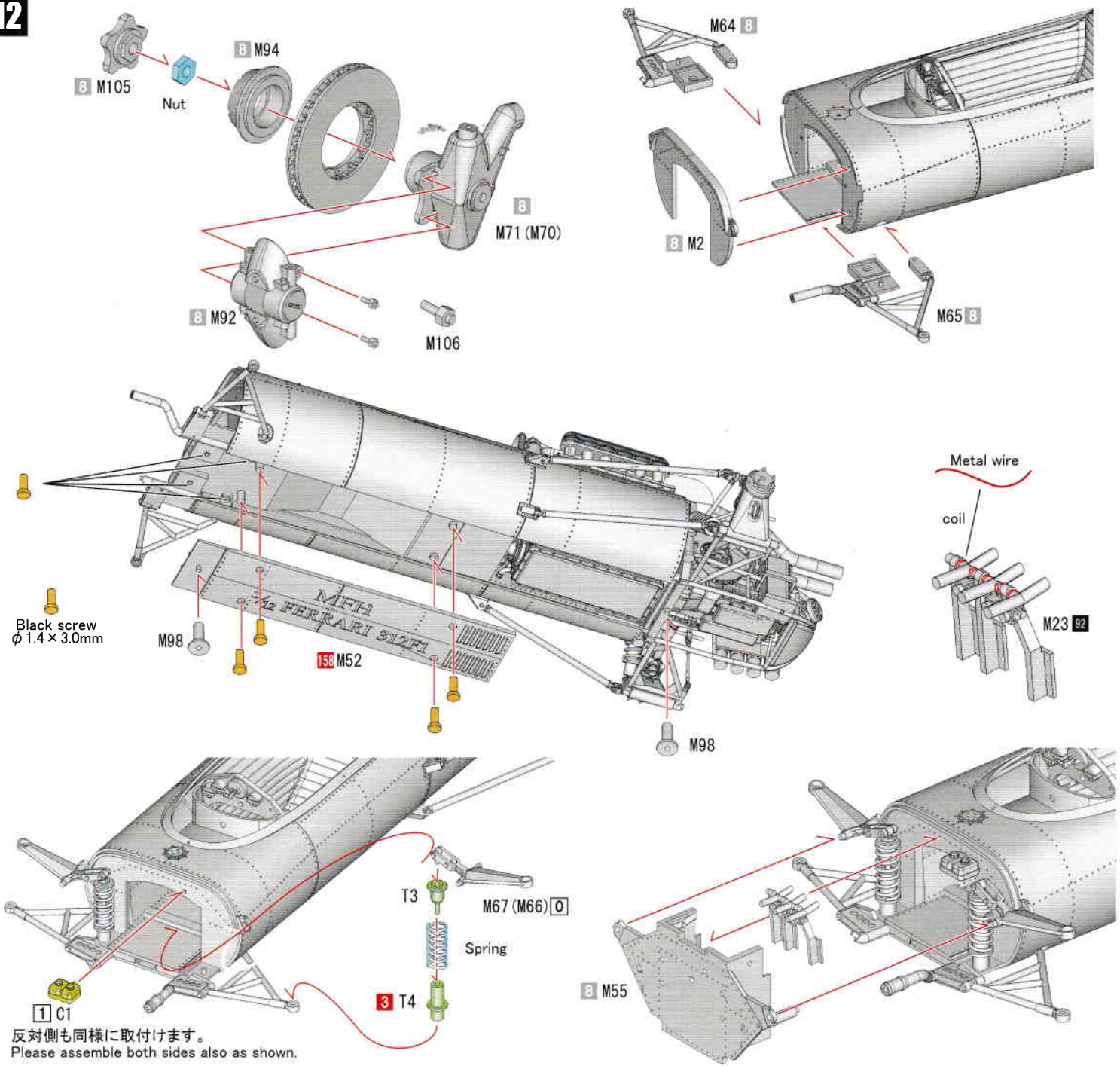
11**12**

13

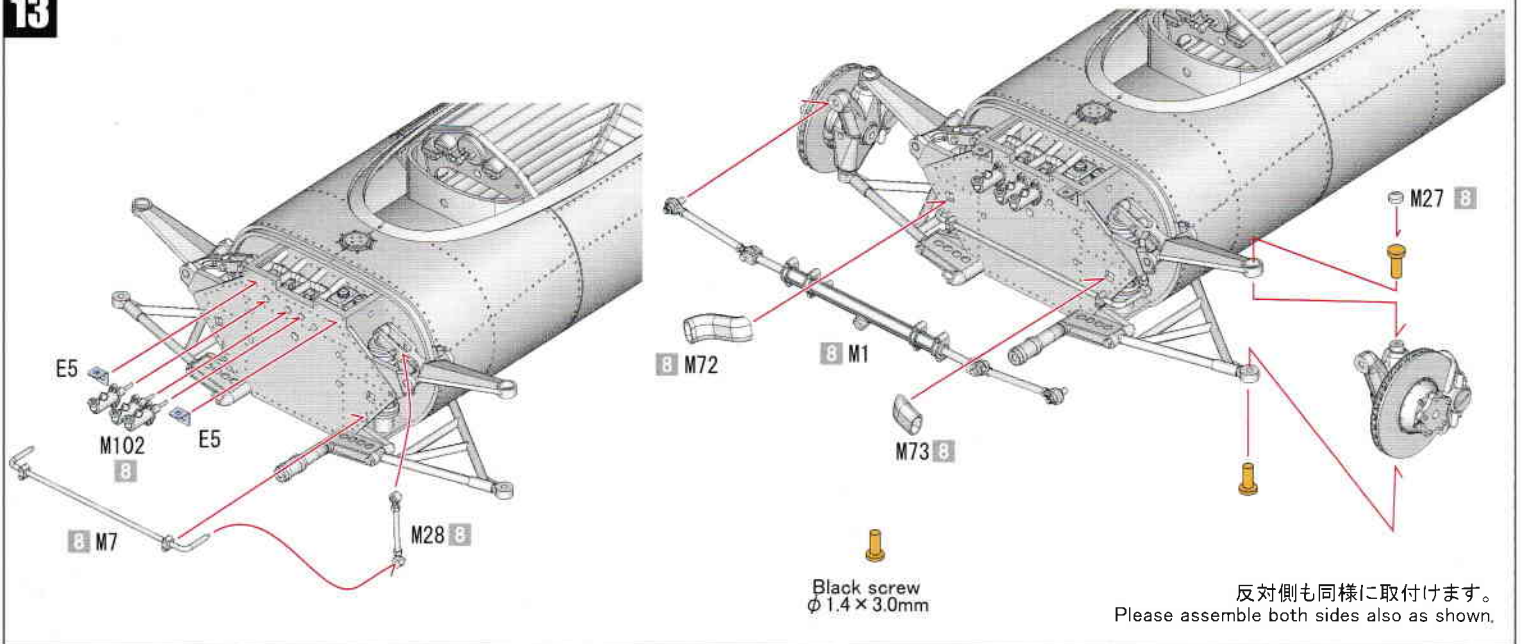

14

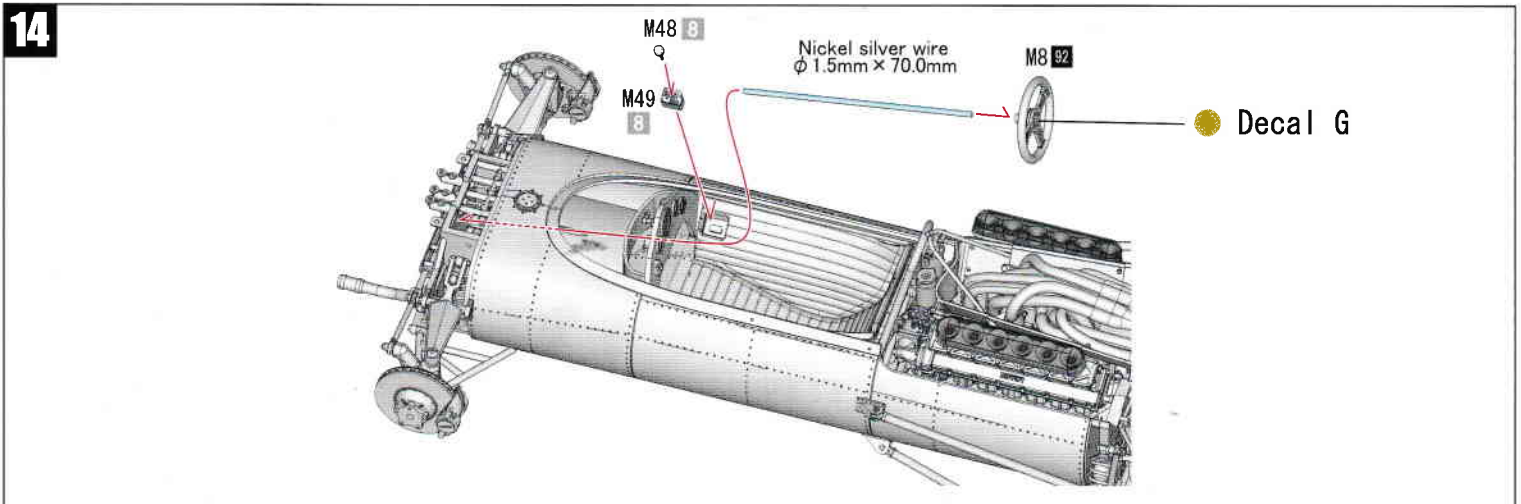

15

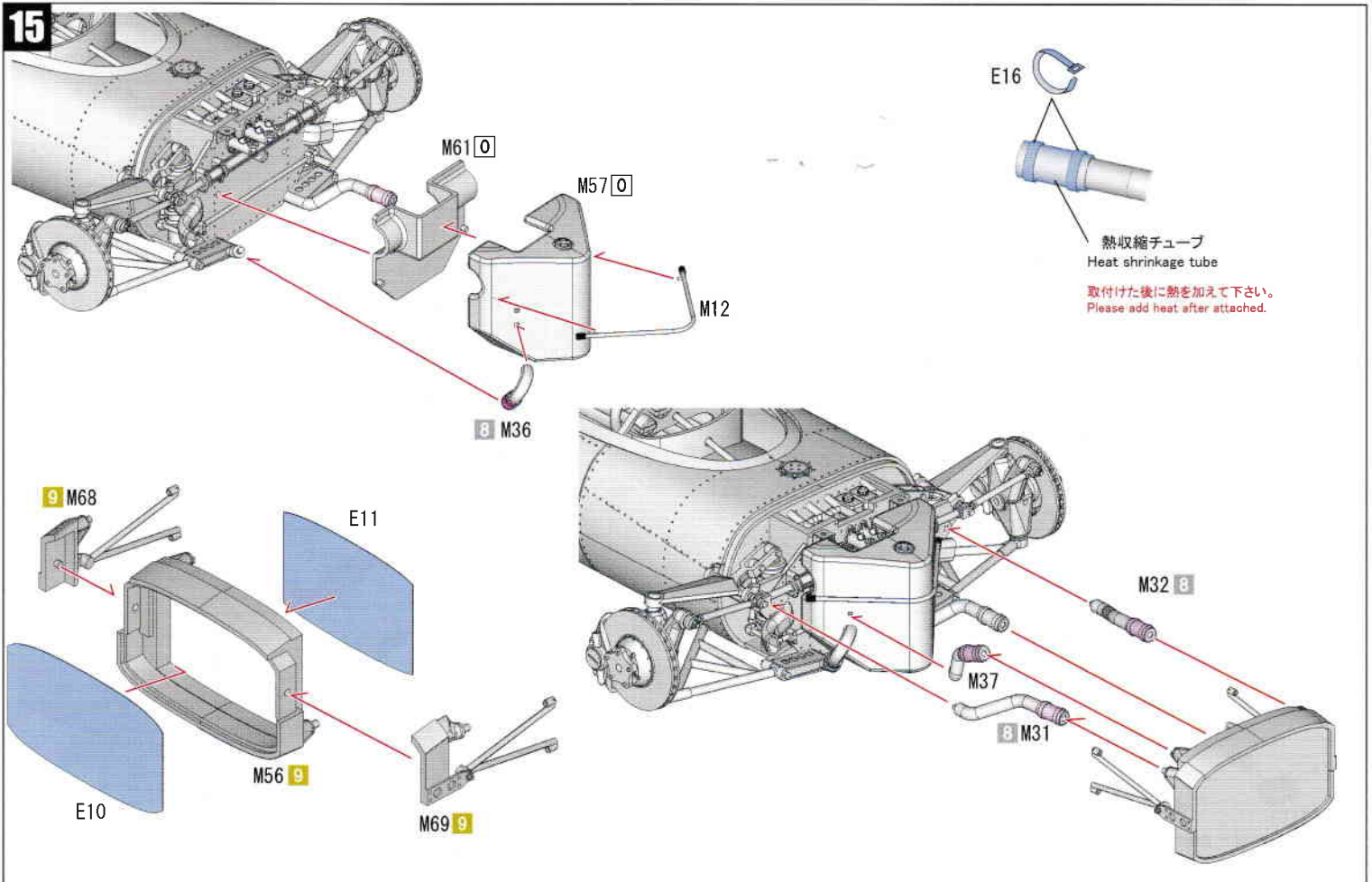

Ver. A

Ver. B

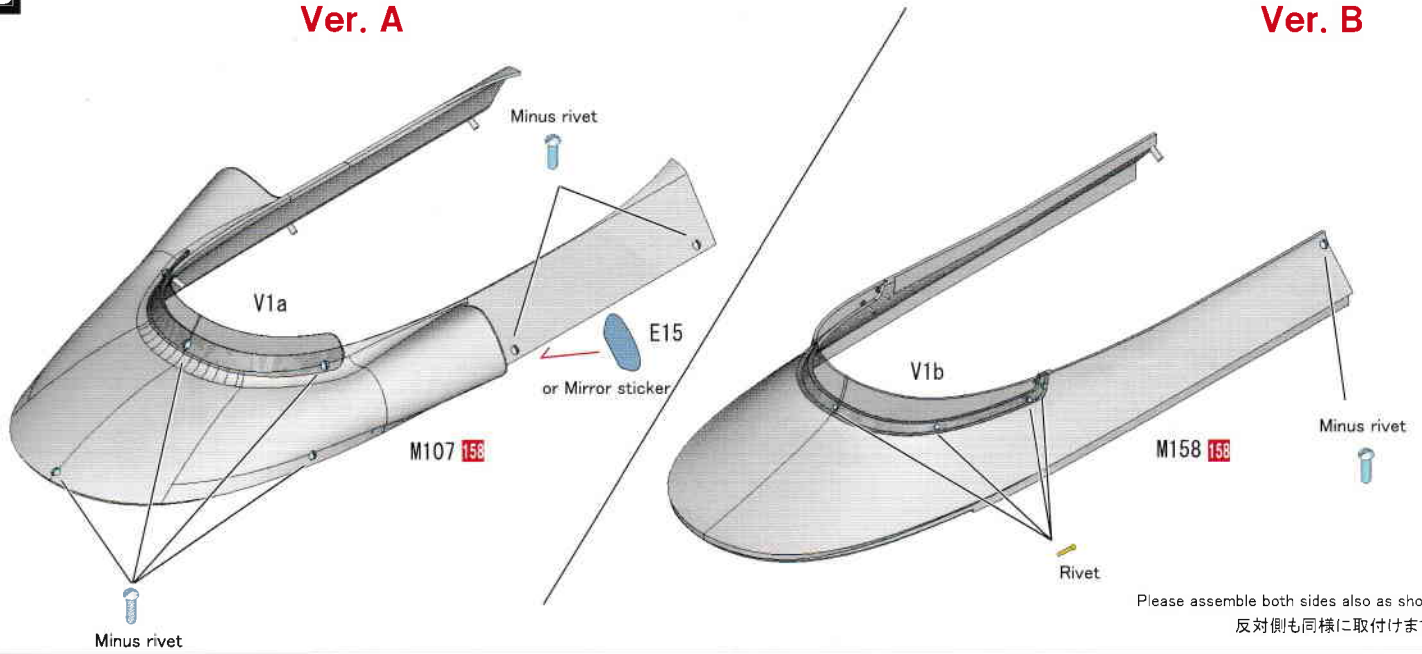

Ver. A

PROVA-NO.30 Decal K Car No. 20

PROVA-NO.30 Decal L Car No. 18

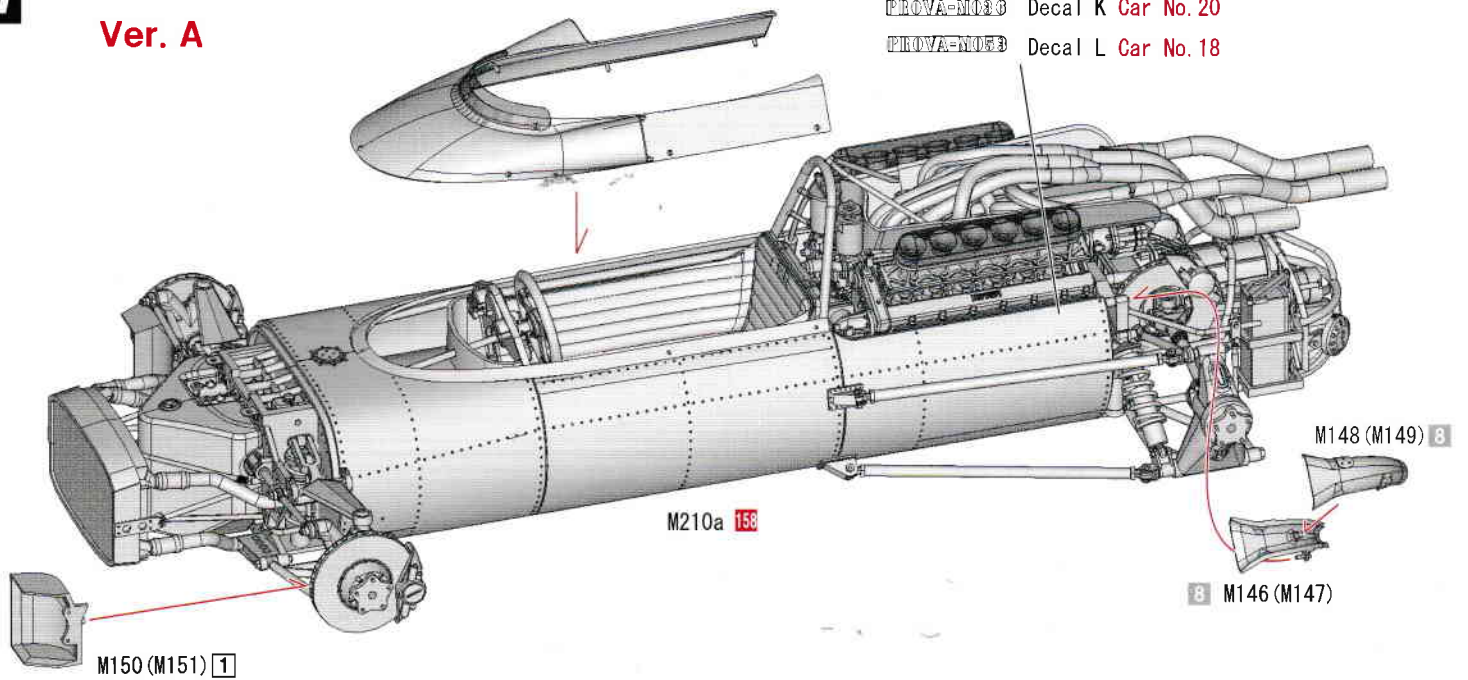

Ver. B

PROVA-NO.30 Decal M

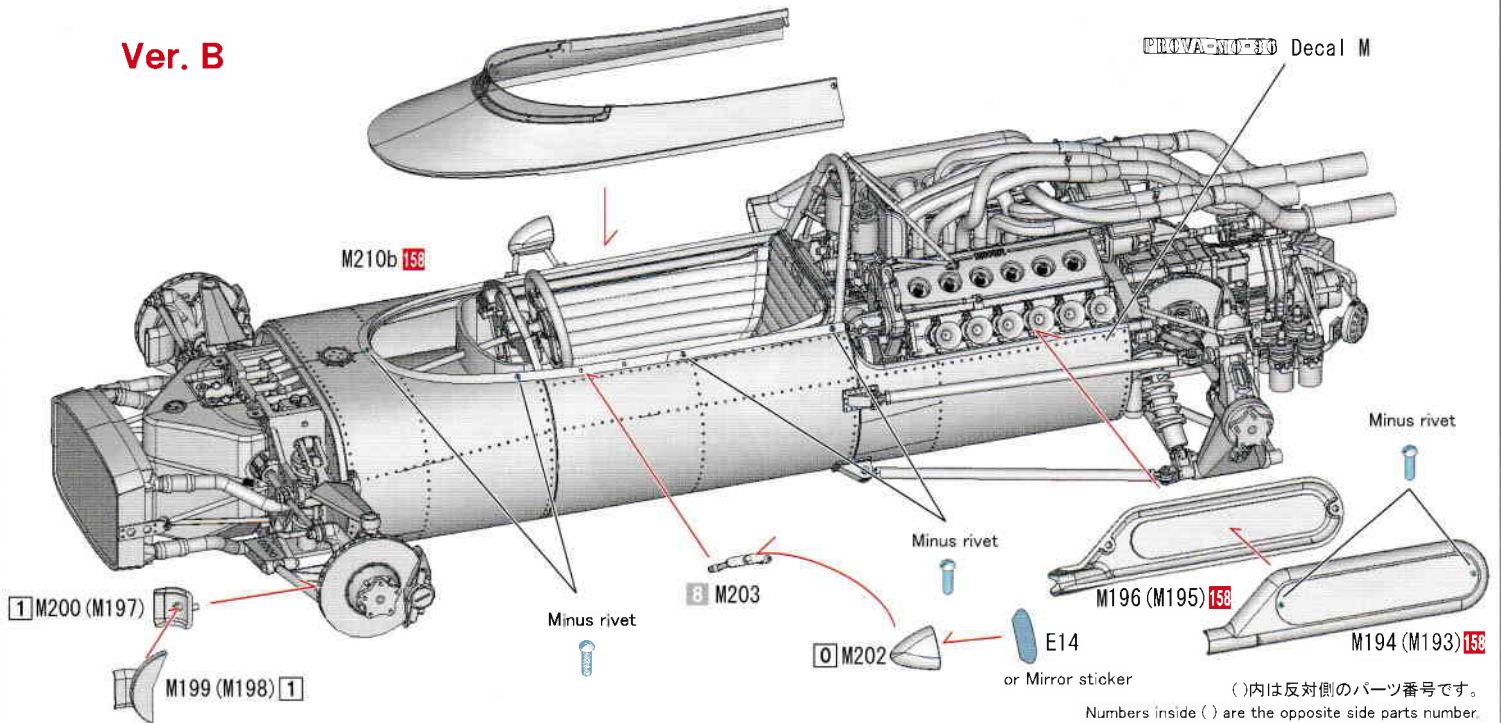

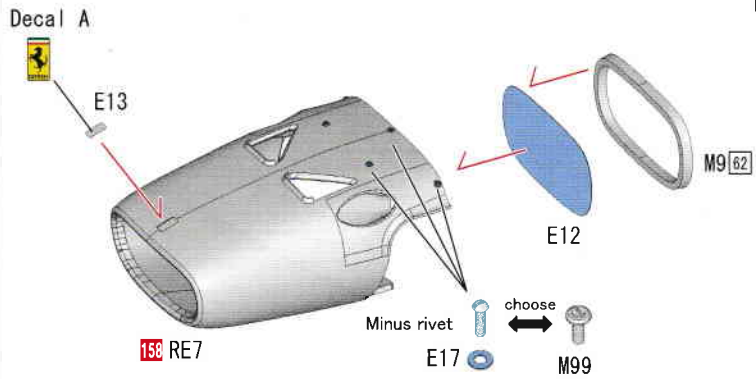
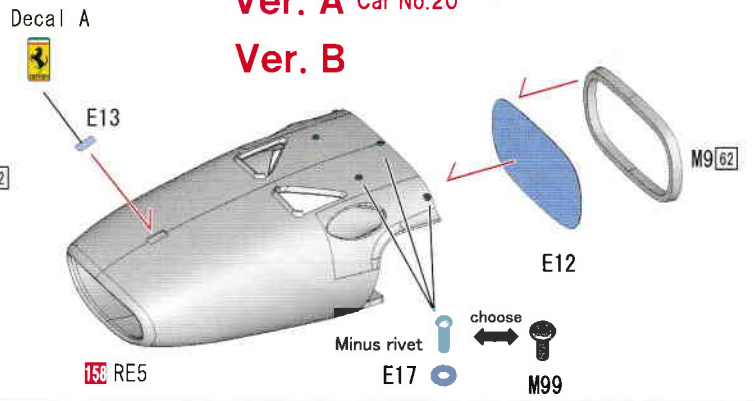
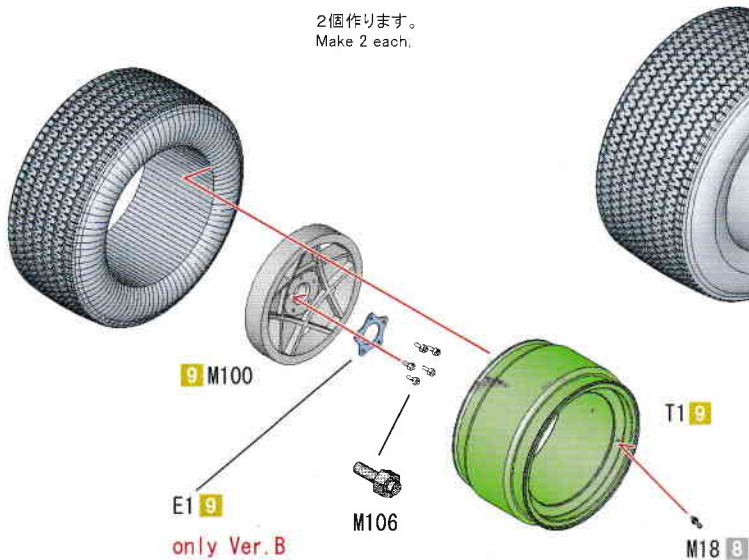
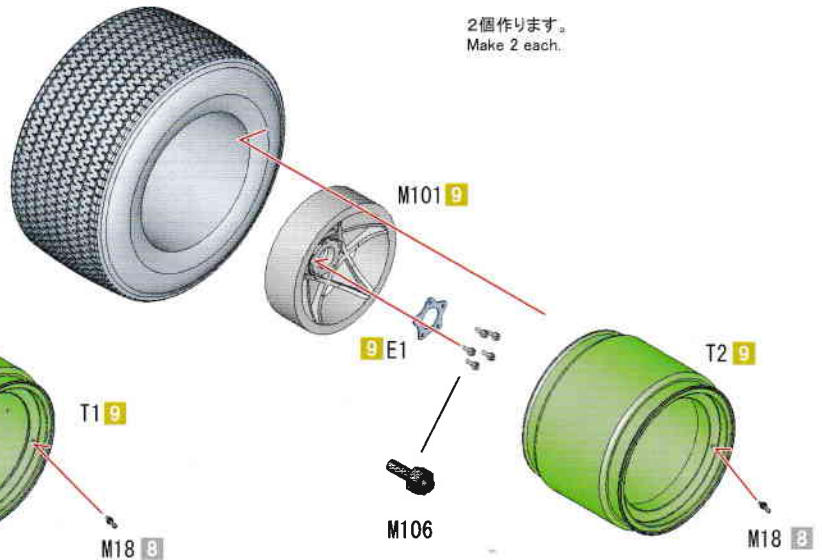
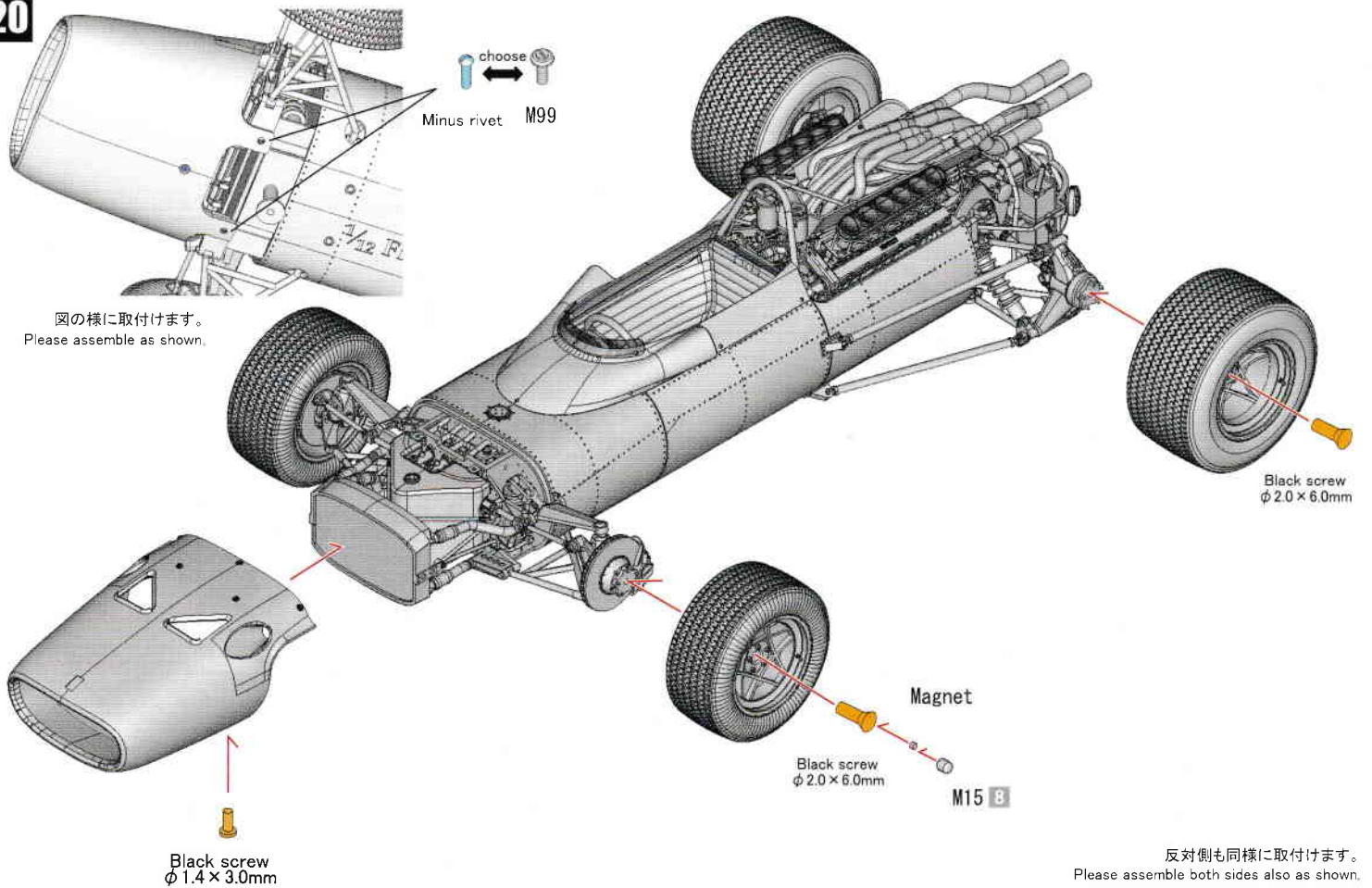
18**Ver. A Car No.18**Please assemble both sides also as shown.
反対側も同様に取付けます。**Ver. A Car No.20****Ver. B****19**2個作ります。
Make 2 each.2個作ります。
Make 2 each.**20**choose
Minus rivet M99図の様に取付けます。
Please assemble as shown.反対側も同様に取付けます。
Please assemble both sides also as shown.

Monaco GP
#18 L. Bandini

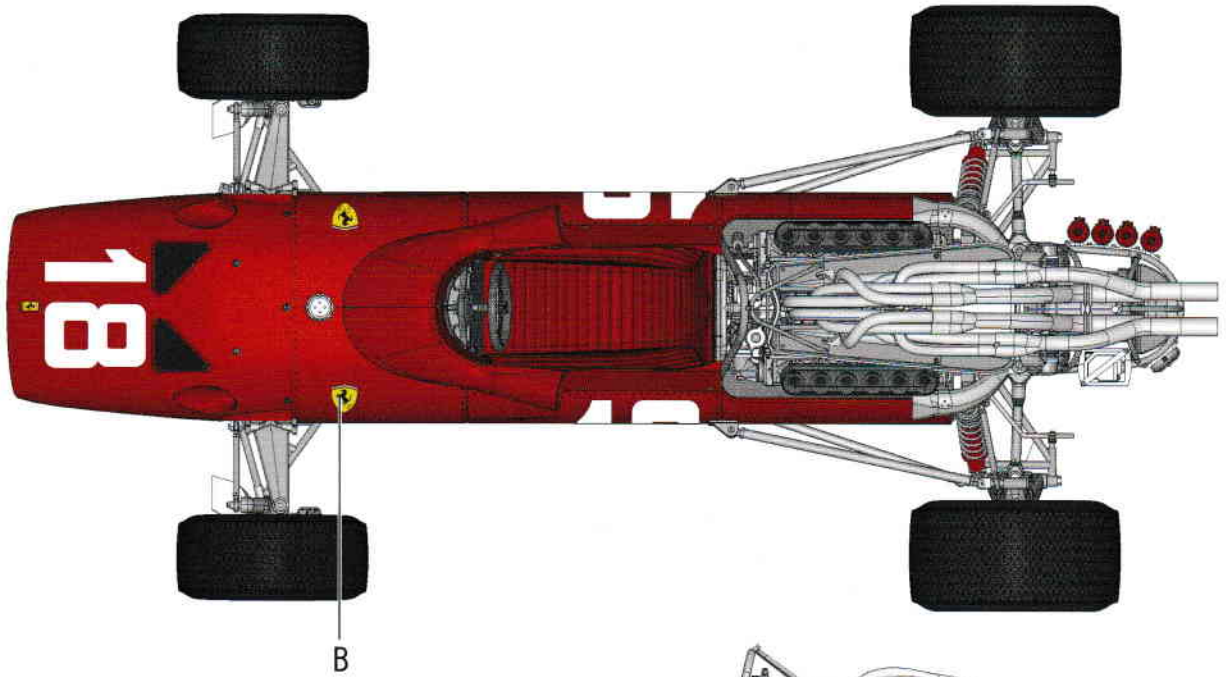

#20 C. Amon

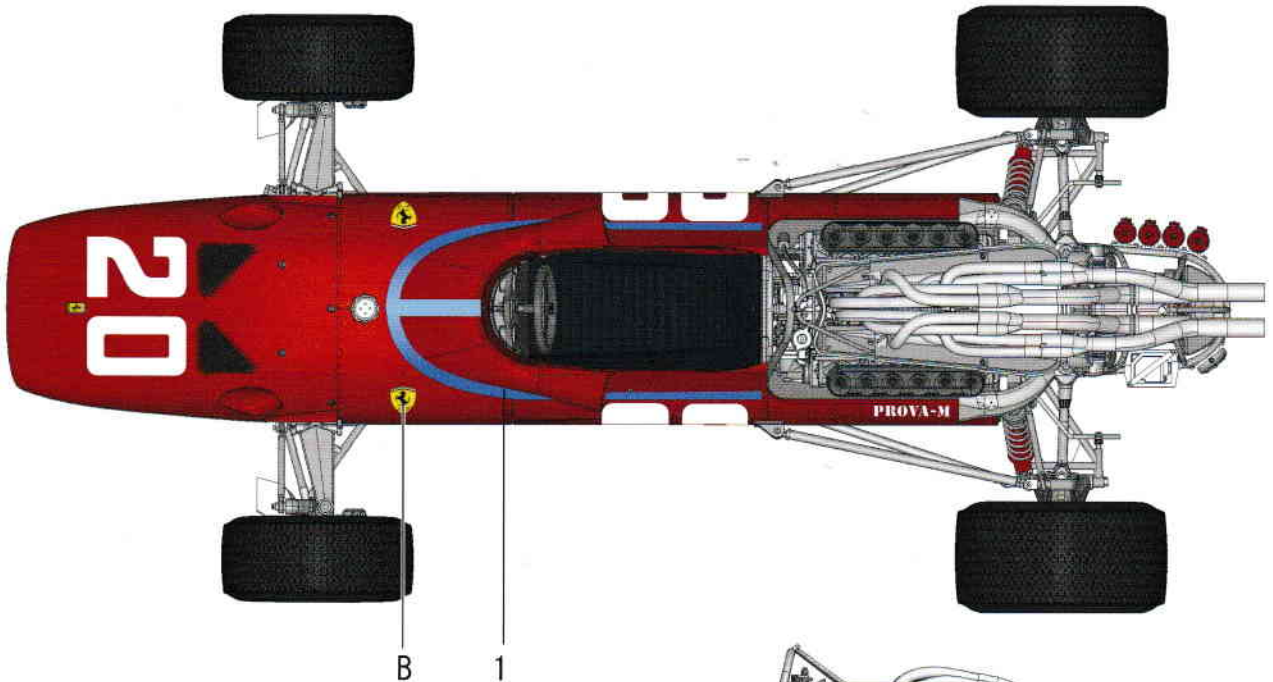

DECAL GUIDE

Italian GP

#2 C. Amon

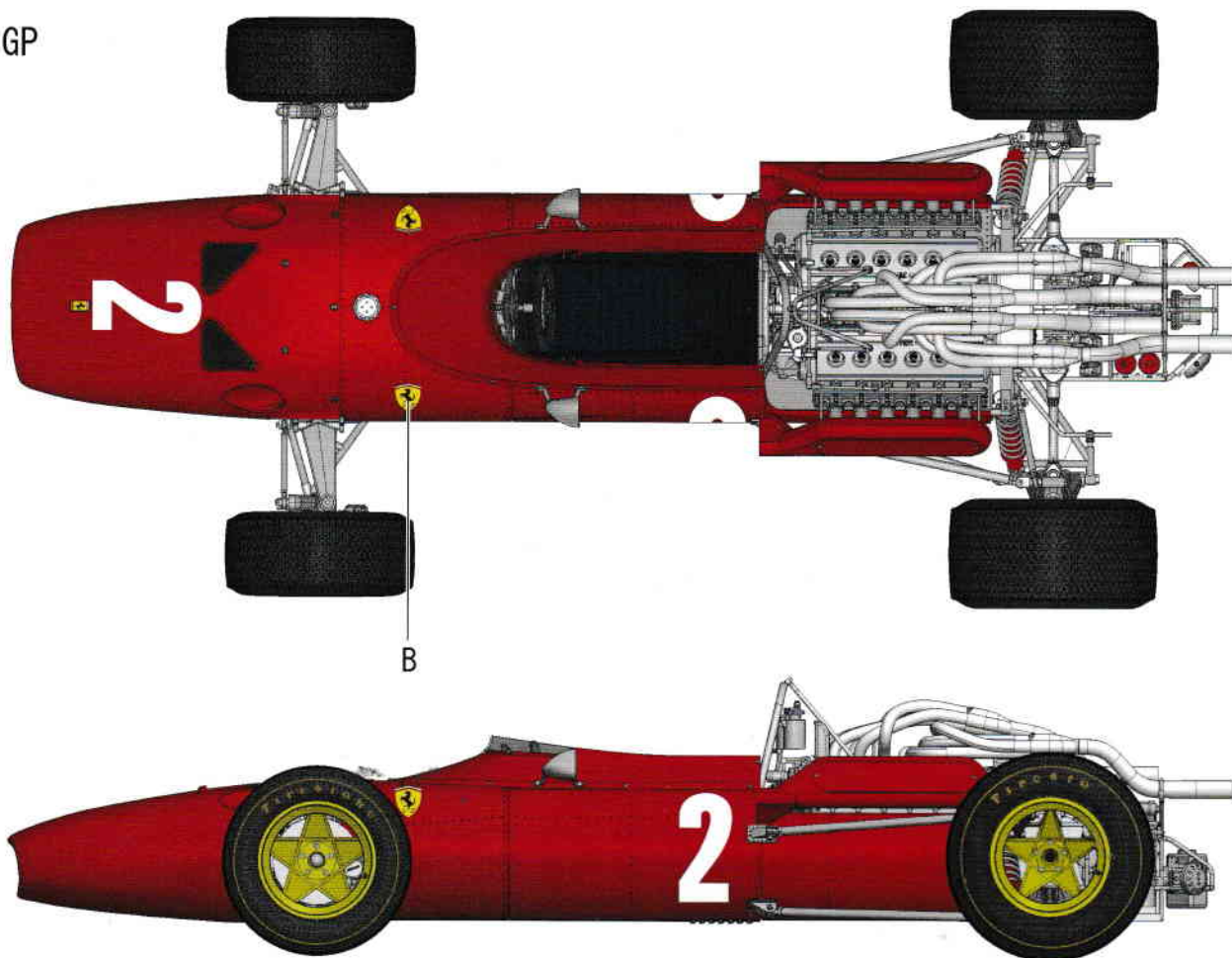

BONUS PARTS

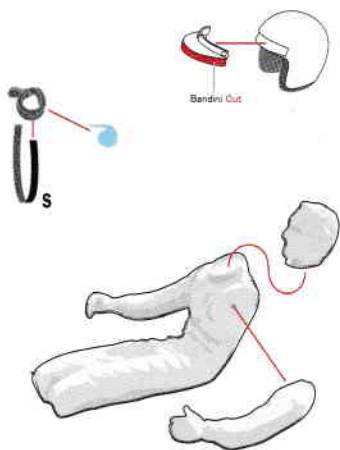

Color table

(注) この説明書ではグンゼ産業(GSIクレオス)の Mr Colorを使用しています。

notice. The color, using on this instruction is Mr color, from GUNZE SANGYO(GSI CREOS).

0	磨き出し	Polish
1	ホワイト	White
2	ブラック	Black
3	レッド	Red

8	シルバー	Silver
9	ゴールド	Gold
28	黒鉄色	Steel
3	ツヤ消し黒	Flat black

62	ツヤ消し白	Flat white
92	半ツヤ黒	Semi gloss black
158	スーパーイタリアンレッド	Super Italian Red

訂正 corrections

20

