

1/12 scale Fulldetail Kit

Ferrari 512BB LM



Ver.A

1979 Sarthe 24hours #62 J.C.Andruet / S.Dini
1979 Sarthe 24hours #63 C.B.Léna / M.Leclère / P.Gregg

Ver.B

1979 Sarthe 24hours #64 J.P.Delaunay / C.Grandet / P.Henn

Ver.C

1980 Sarthe 24hours #75 L.Guittény / G.Bleynie / J.P.Libert

Ver.D

1980 Sarthe 24hours #79 S.Dini / F.Violati / M.Micangeli

MFH

Model Factory Hiro

2-3-8 Higashihokima, Adachi-ku, Tokyo 121-0063
Phone: 81-3-5851-2522 Fax: 81-3-5851-2524

URL: <http://www.modelfactoryhiro.com>
E-mail: cus@modelfactoryhiro.com

注意

- 組立て前に十分に仮組みを行って下さい。
- メタルパーツは変形している場合がありますが変形を調整しながら組立てを行って下さい。調整の際、多少の曲げは可能ですが破損にはご注意ください。
- レジンパーツの調整については、ドライヤー等で温めながら破損に注意しゆっくり行って下さい。
- 組立ての際、削り合わせ等が必要な部分もありますのでご注意ください。
- メタルパーツはバリやパーティングライン等を処理した後に、プライマーサフェーサー等で下地処理を行って下さい。
- レジンパーツは組立て、塗装前に離型剤クリーナー等で洗浄して下さい。
- 組立てには瞬間接着剤やエポキシ系ボンドをご使用下さい。
- デカールはファイル等に入れ、高温多湿を避けて保存して下さい。
- 本製品は、中級者以上を対象とした組立てキットです。このキットには、尖った部品や小さな部品が含まれています。子供の誤飲や怪我、又はビニール袋による窒息などの事故にご注意ください。塗料、工具、接着剤等は、説明書に従い正しくお使い下さい。

CAUTION

- Please try temporarily constructing the kit before applying any adhesives.
- Metal parts may be slightly out of shape when first taken out of the box. You can restore the shape by carefully bending the part, but take caution as overexerting the part will cause it to snap.
- You can change the shape of the resin casting parts by applying heat (eg. using a dryer), but please be careful of damaging the part
- Please be aware that some parts may have to be altered by cutting before they can fit together.
- After blur/parting lines have been removed from metal parts, please apply under coating (eg. primer surfacer) before continuing.
- Please clean resin parts (eg. using releasing agent) before applying color.
- Please use super glue or epoxy resin when building the kit.
- Protect decals by keeping them in dry and cool place inside a folder/file holder.
- This kit is intended for ages 16 and over. Please keep out of reach from children as kit contains many small/sharp parts. Please read instructions carefully before applying colour/adhesives/altercation of parts etc.

PARTS LIST

TURNED PARTS

□ T1	フロントホイールリム	Front wheel rim	2
□ T2	リアホイールリム	Rear wheel rim	2
□ T3	シャフト	Shaft	4
□ T4	センターロック	Center lock	4
□ T5	ファンネル	Funnel	12
□ T6	エキゾーストエンド	Exhaust end	4
□ T7	ライトリム	Light rim	2
□ T8	給油口	Fuel filler	2

VACUUM PARTS

□ V1	ウインドシールド	Wind shield	1
□ V2	サイドウィンドウ(左)	Side Window L	1
□ V3	サイドウィンドウ(右)	Side Window R	1
□ V4	ヘッドライトカバー(左)	Head light cover L	1
□ V5	ヘッドライトカバー(右)	Head light cover R	1
□ V6	フォグランブカバー	Fog lamp cover	1

CLEAR PARTS

□ C1~C15

RUBBER PARTS

□ R1~7

OTHERS

□ 黒ネジ	Black screw	53
□ 平リベット	Flat rivet	7
□ 洋白線	Nickel silver wire	Ver. A
		1
		2
		1
□ 真鍮線	Brass wire	2
□ コード黒	Black code	1
		1
		Ver. A
		1
□ コード青	Blue code	1
□ コード黄	Yellow code	1
□ 黒チューブ	Black tube	1
□ クリアチューブ	Clear tube	1
		1
		1
□ 熱収縮チューブ(黒)	Black heat shrinkable tube	1
□ 熱収縮チューブ(赤)	Red heat shrinkable tube	1
□ アルミシート	Aluminium sheet	1
□ カットイングシート	Cutting sheet	1
□ クリアシート	Clear sheet	1
□ メーターガラス	Meter glass	3
		1
		1
		6
□ ダンパースプリング	Damper spring	4
□ ジャックスプリング	Jack spring	1
□ 引きばね	Pull spring	4
□ 磁石	Magnet	1
□ シートベルトセット	Seat belt set	1
□ UVプリントセット	UV Print set	1
□ フロントタイヤ	Front tire	2
□ リヤタイヤ	Rear tire	2
□ エッチング	Photo etched plate	3
□ デカール	Decal	2
		Ver. A/C
		Ver. B/D
		1

Color table

(注) この説明書ではグンゼ産業(GSIクレオス)の Mr Colorを使用しています。
notice. The color, using on this instruction is Mr.color, from GUNZE SANGYO(GSI CREOS).

1	白	White	10	銅	Copper	48	クリアイエロー	Clear yellow
3	赤	Red	16	濃緑色	Dark green	49	クリアオレンジ	Clear orange
4	黄	Yellow	28	黒鉄色	Steel	58	黄橙色	Orange
7	ブラウン	Brown	35	明灰白色	IJN Gray	62	ツヤ消し白	Flat white
8	シルバーク	Silver	46	クリア	Clear	92	半ツヤ黒	Semi gloss black
9	ゴールド	Gold	47	クリアレッド	Clear red	322	フタロシアンブルー	Phthalo cyan blue

1

Drill hole $\phi 2.0\text{mm}$

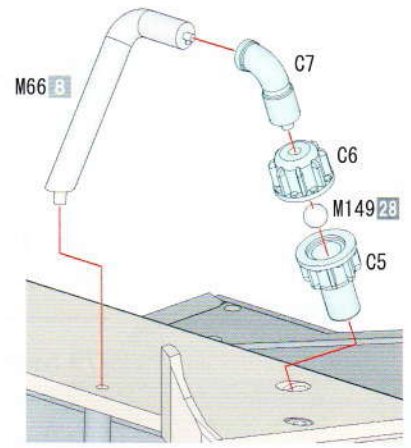
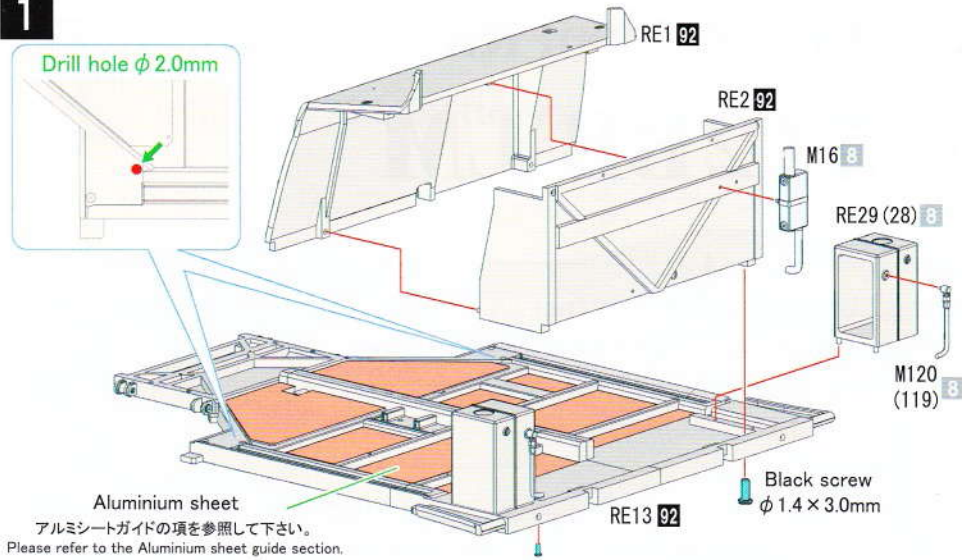

Seat belt A

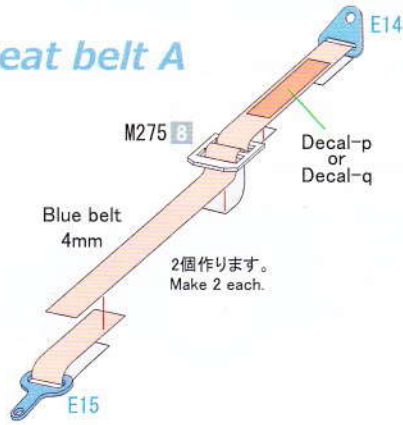

Seat belt B



Seat belt C

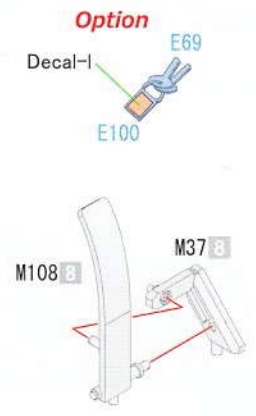
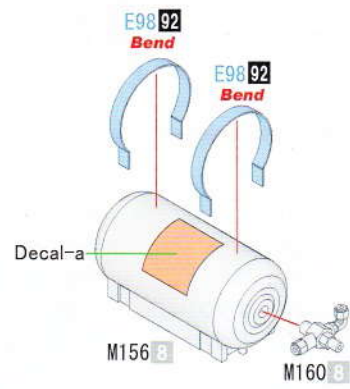
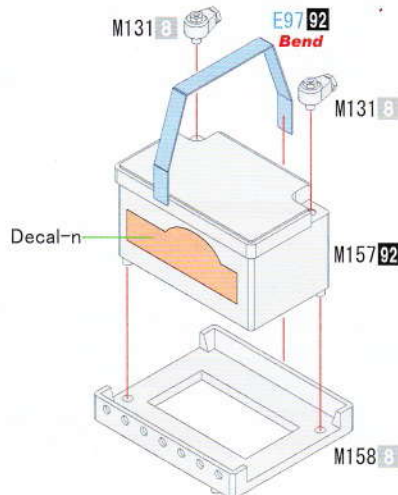
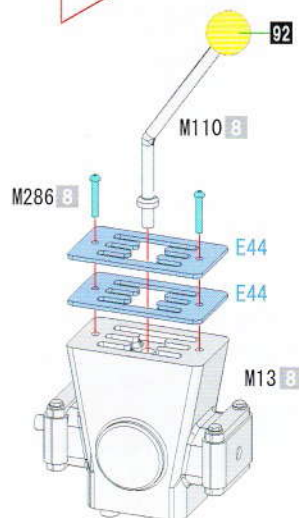
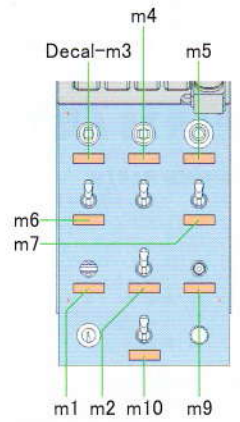
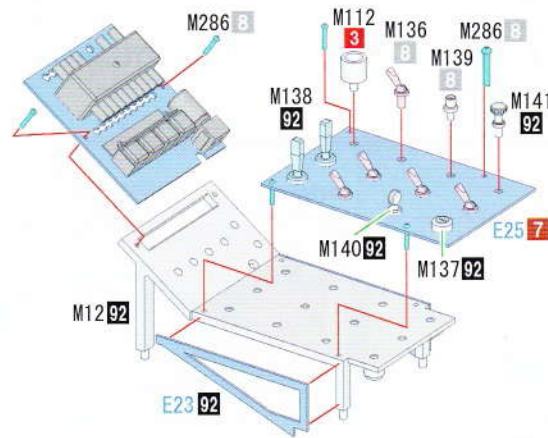
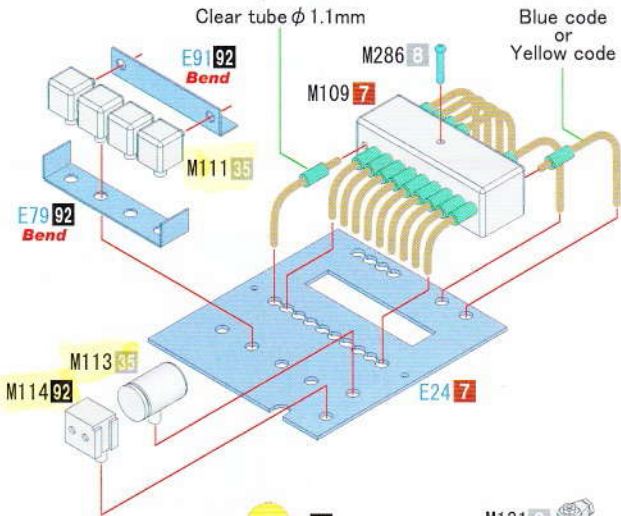
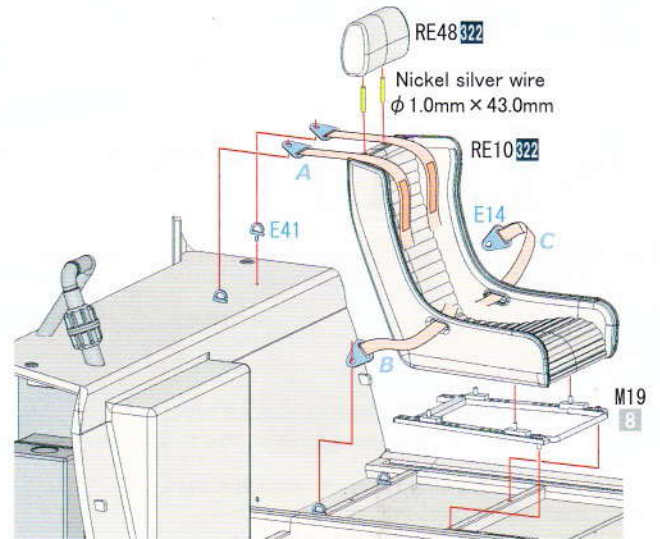

2

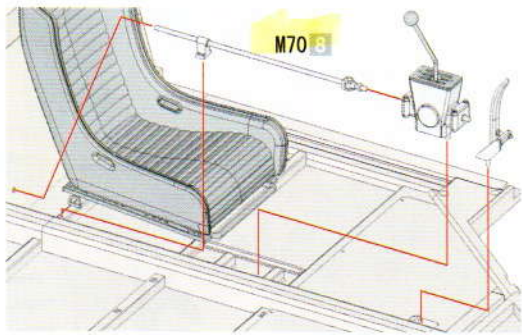

M70 8

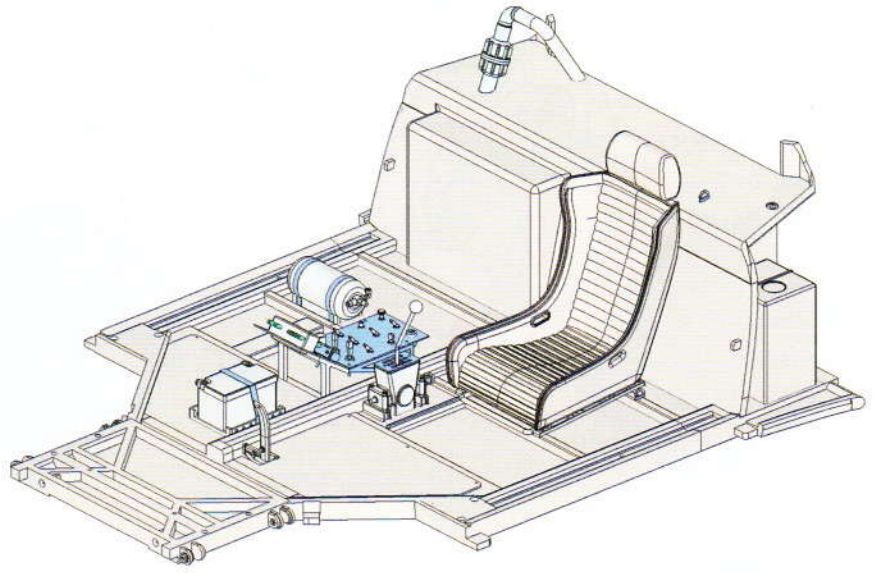

お手持ちの資料を
参考にどちらか
選択して下さい。
Choise

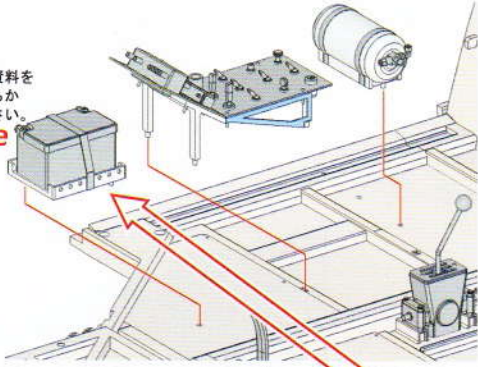

3

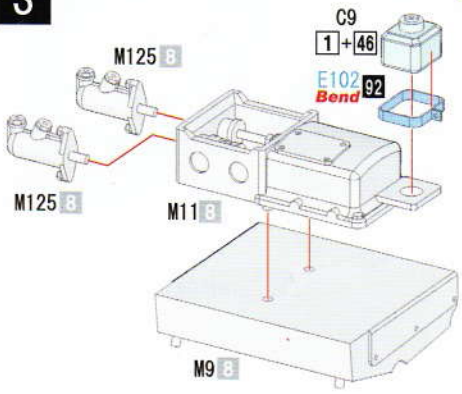

Choise
お手持ちの資料を
参考にどちらか
選択して下さい。

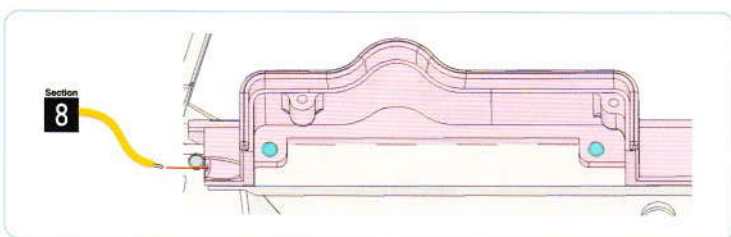
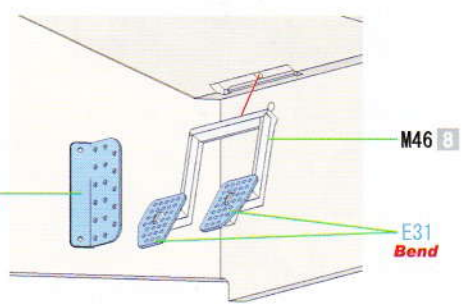
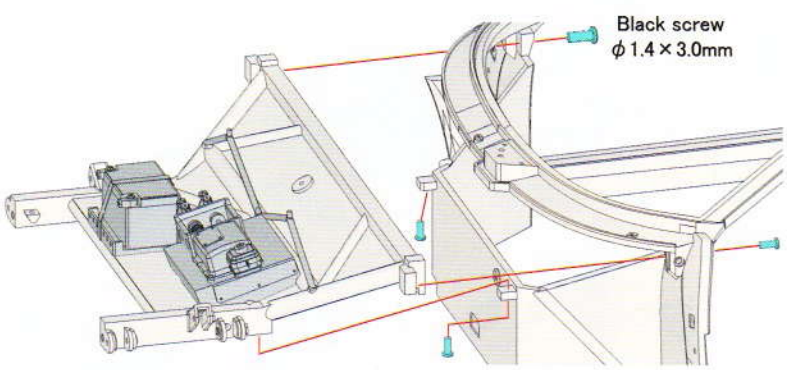
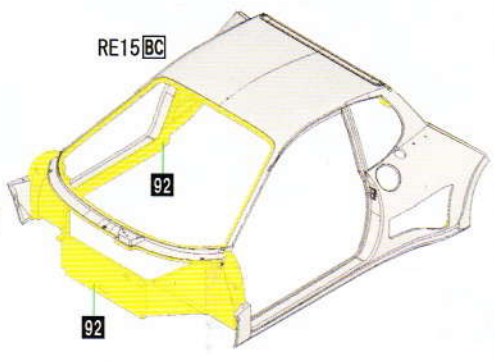
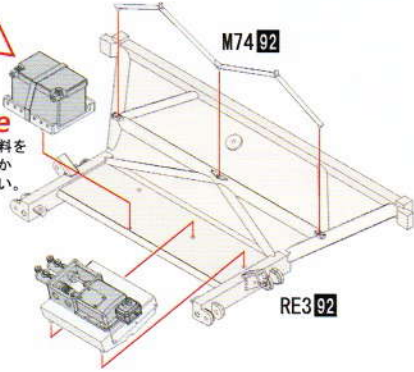

Section 8

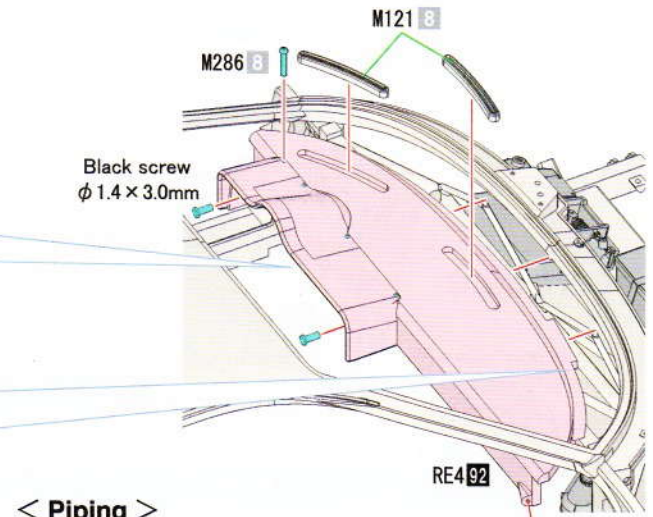
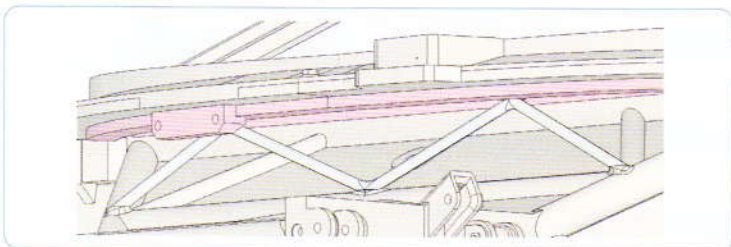

< Piping >

Nickel silver wire $\phi 0.5\text{mm}$
+
Clear tube $\phi 1.1\text{mm}$

Section 8

4

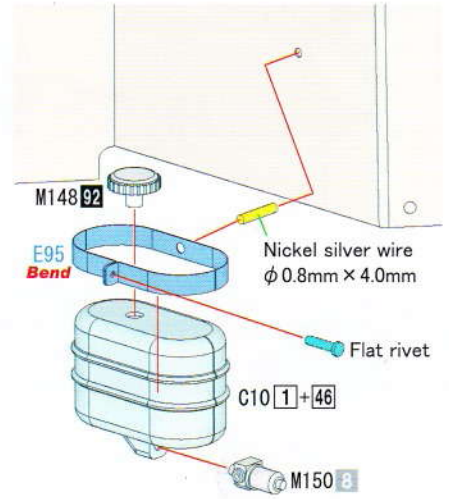
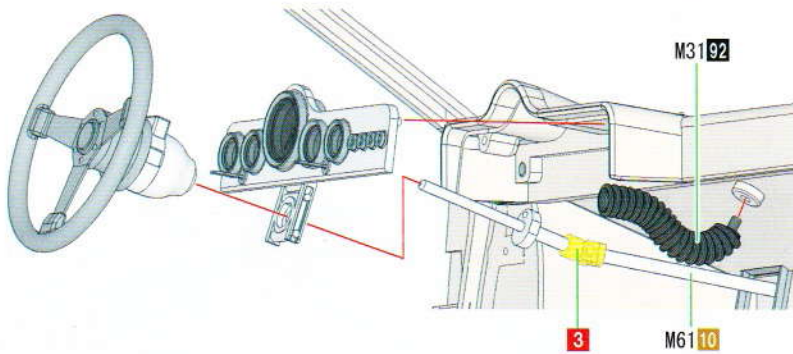
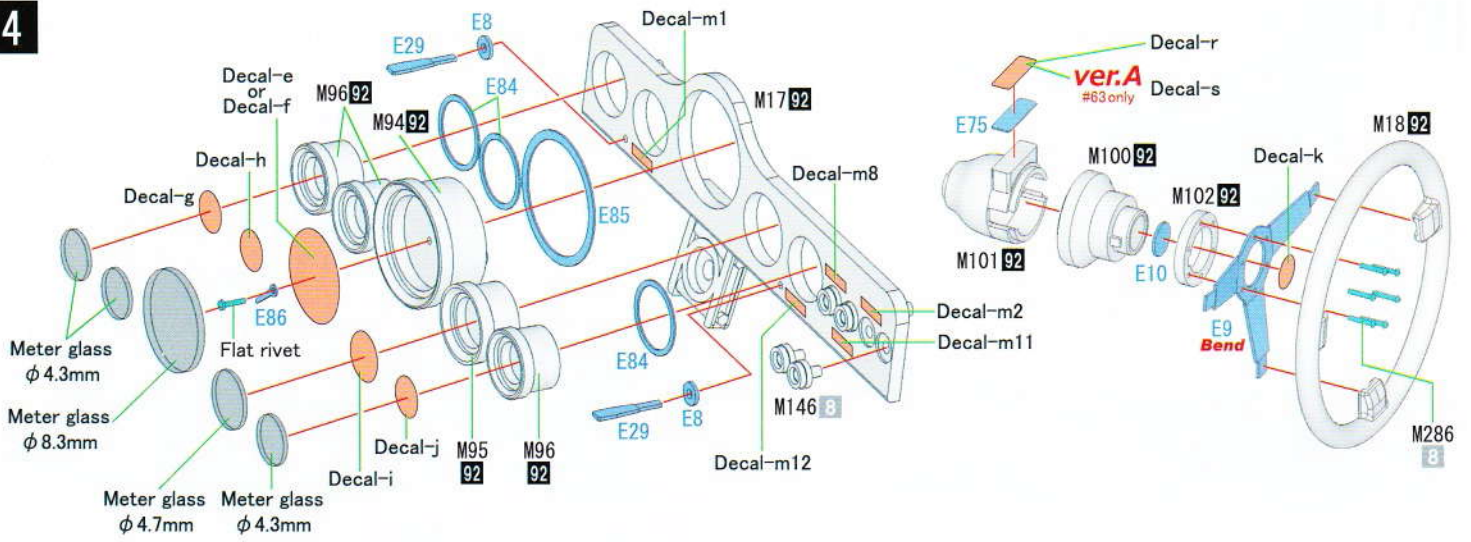

5

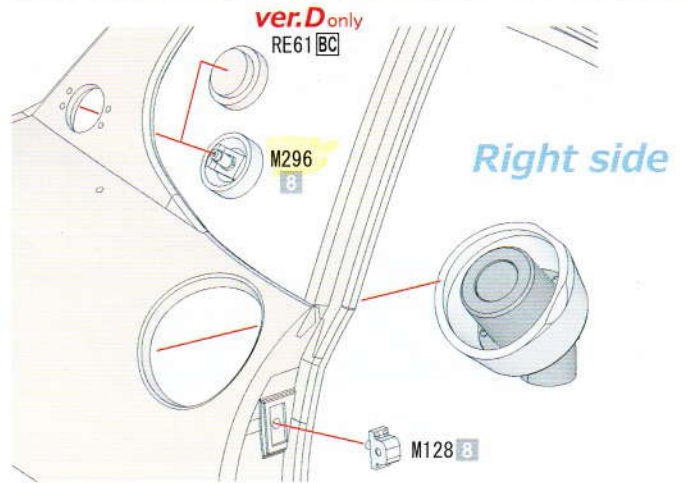
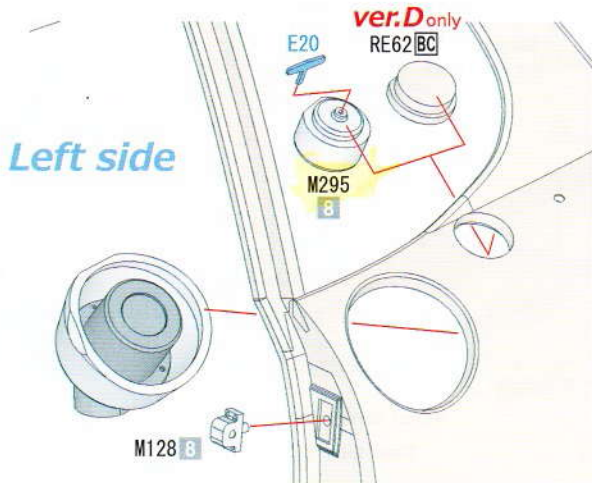
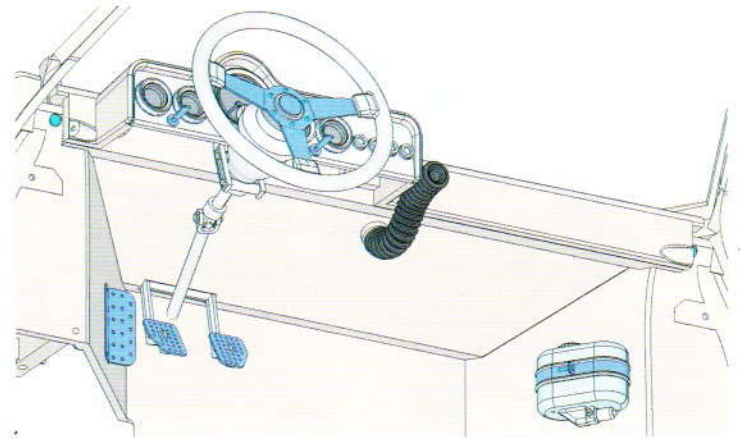
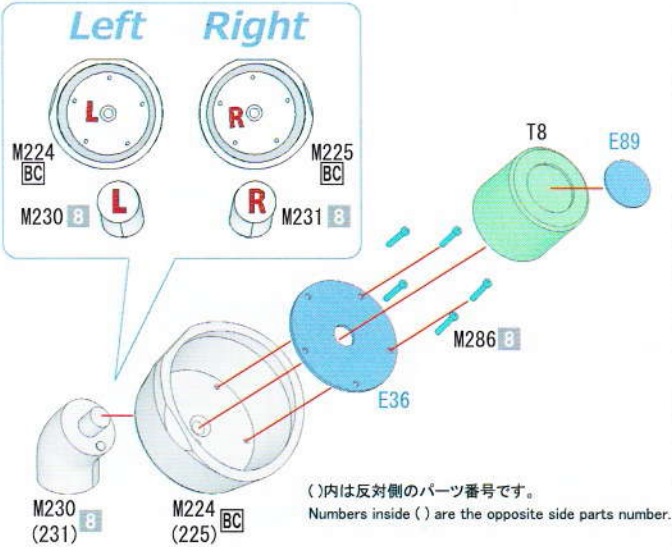

ver.A/B/C

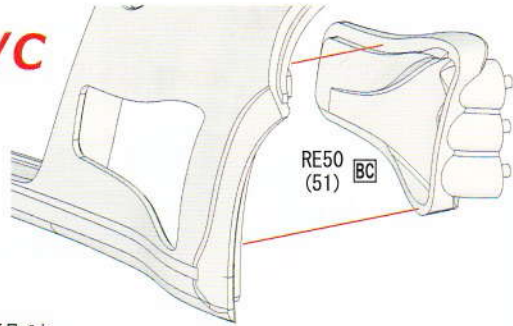

()内は反対側のパーツ番号です。
 Numbers inside () are the opposite side parts number.
 反対側も同様に取り付けます。
 Please assemble the other side also as shown.

ver.D

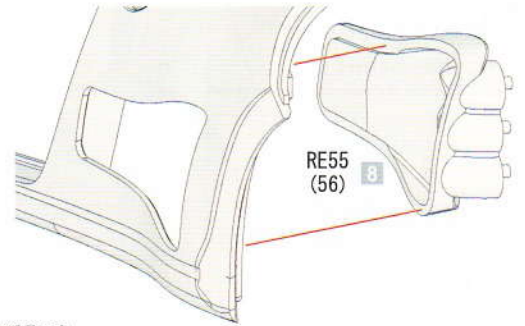

()内は反対側のパーツ番号です。
 Numbers inside () are the opposite side parts number.
 反対側も同様に取り付けます。
 Please assemble the other side also as shown.

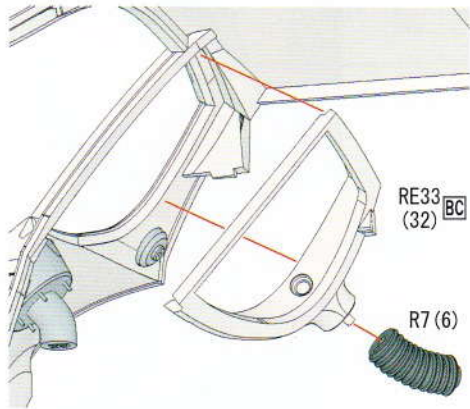

()内は反対側のパーツ番号です。
 Numbers inside () are the opposite side parts number.
 反対側も同様に取り付けます。
 Please assemble the other side also as shown.

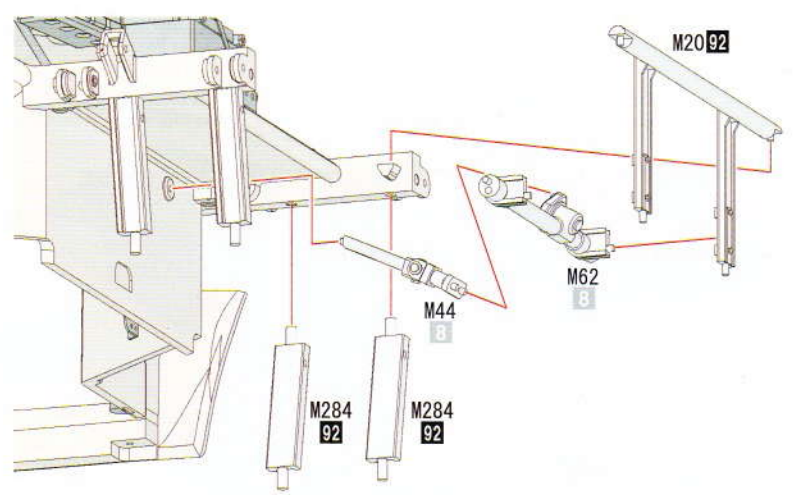
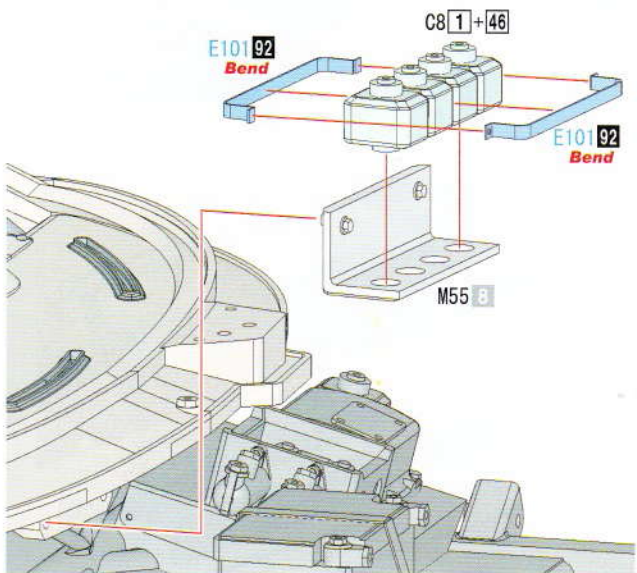
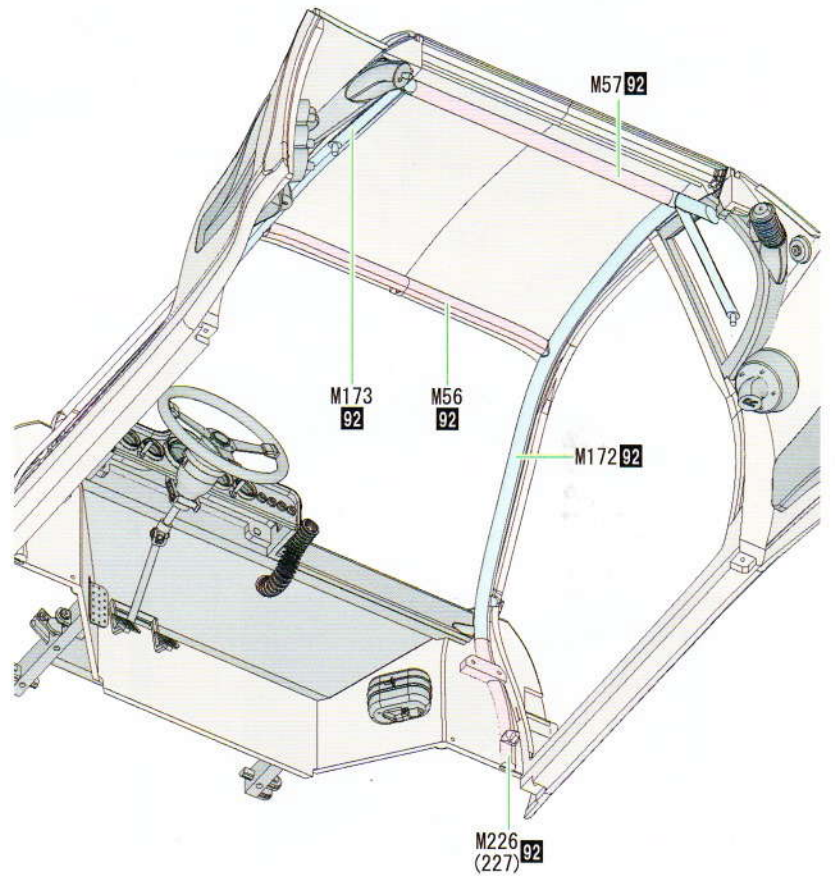
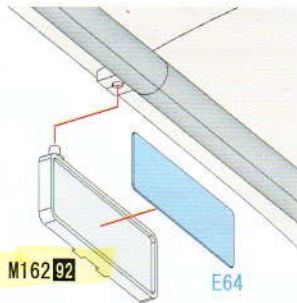

7

反対側も同様に取り付けます。
Please assemble the other side also as shown.

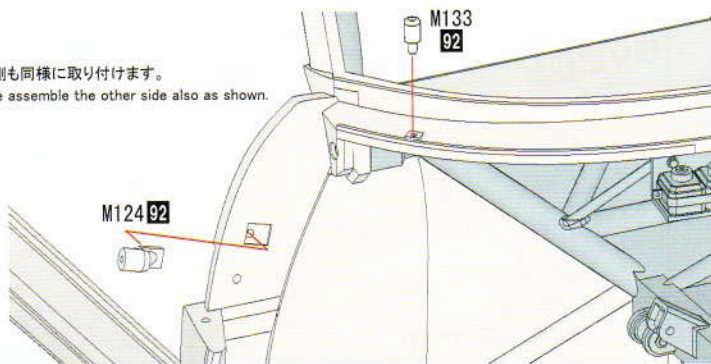

ver.D

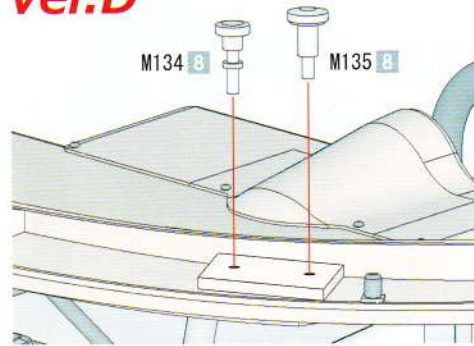

8

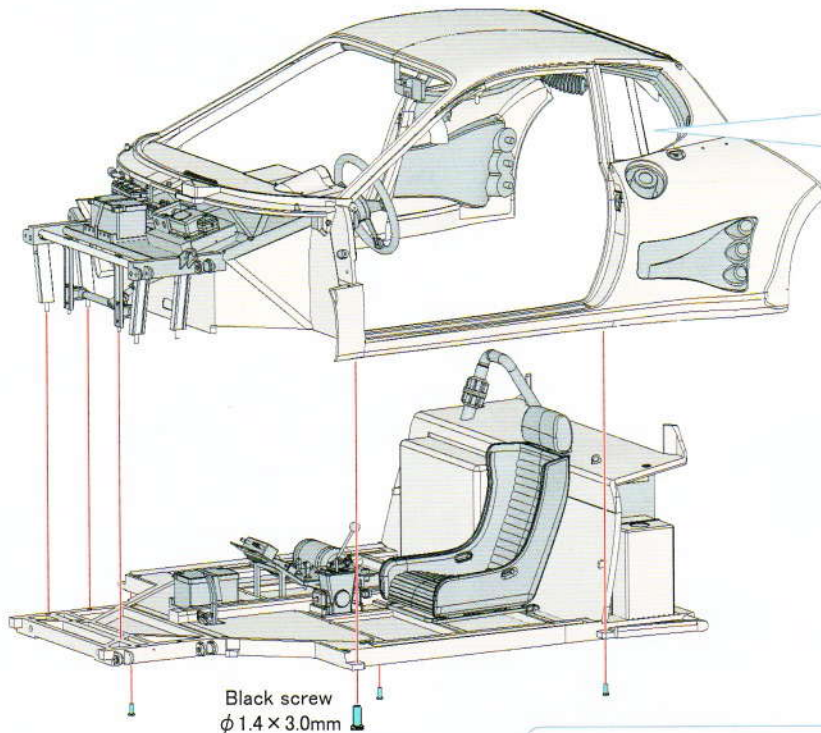

Black screw
φ 1.4 × 3.0mm

< Piping >

Nickel silver wire φ 0.5mm
+
Clear tube φ 1.1mm

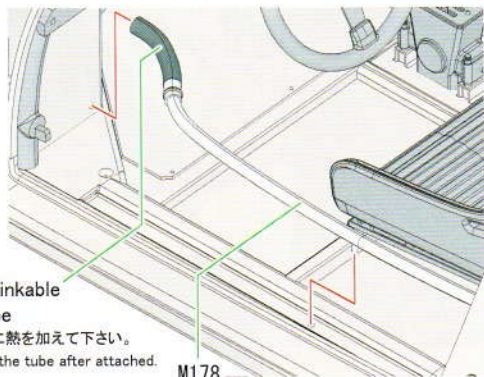

Heat shrinkable tube

取り付け後に熱を加えて下さい。
Please heat the tube after attached.

M178
(181)

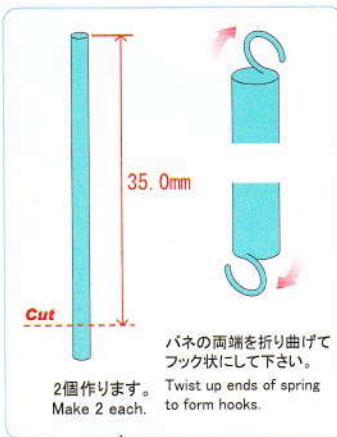

35.0mm

Cut

2個作ります。
Make 2 each.

バネの両端を折り曲げてフック状にして下さい。
Twist up ends of spring to form hooks.

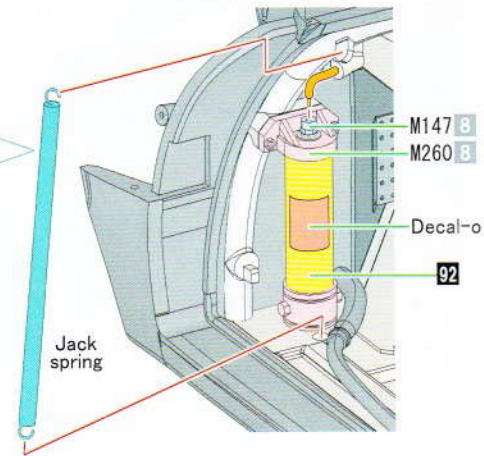

Jack spring

M147 8
M260 8
Decal-o
92

()内は反対側のパーツ番号です。
Numbers inside () are the opposite side parts number.

反対側も同様に取り付けます。
Please assemble the other side also as shown.

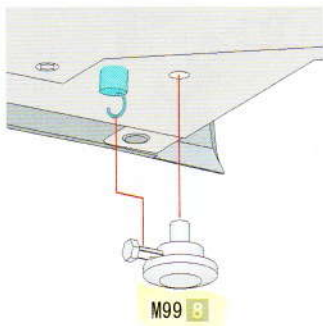

M99 8

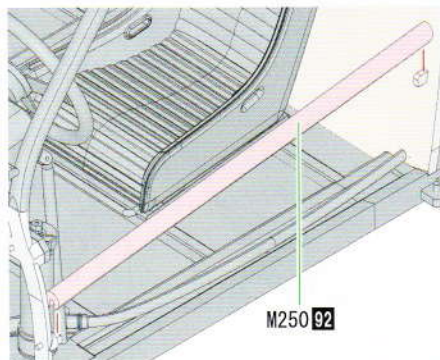

M250 92

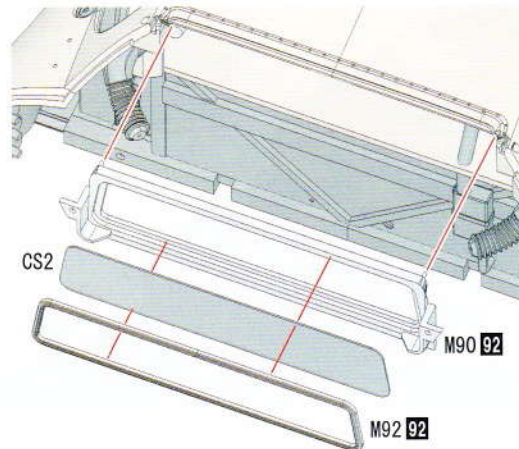

CS2

M90 92

M92 92

9 ver.A/C/D

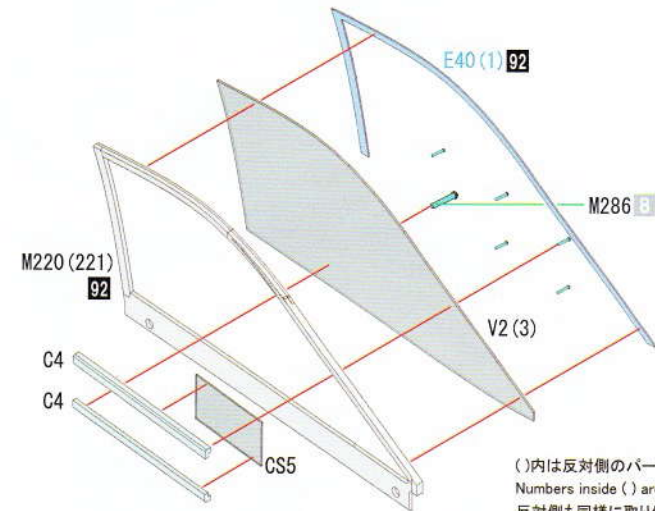
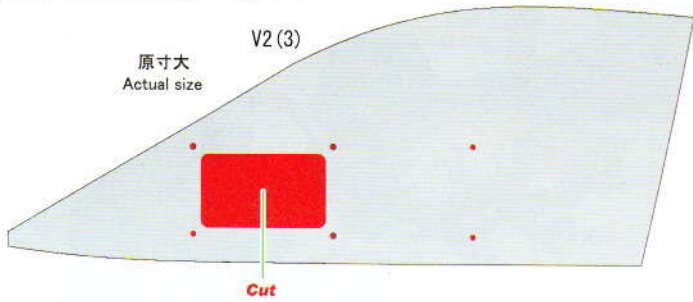

()内は反対側のパーツ番号です。
Numbers inside () are the opposite side parts number.
反対側も同様に取り付けます。
Please assemble the other side also as shown.

ver.B

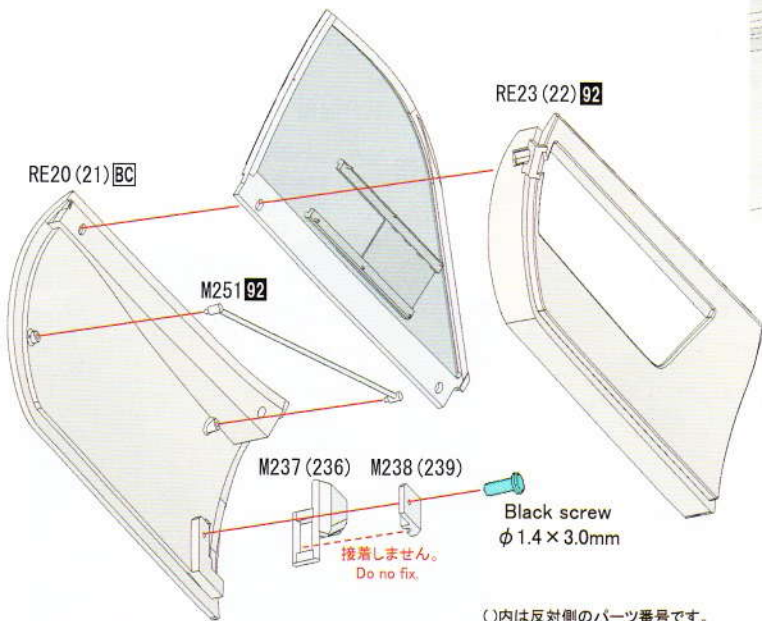
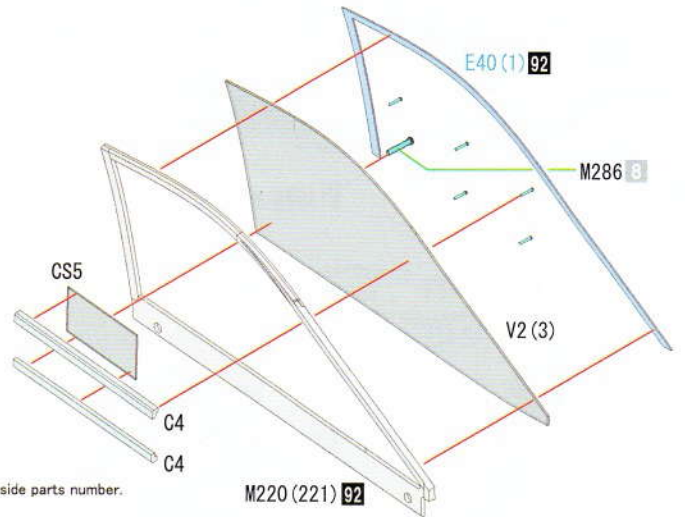
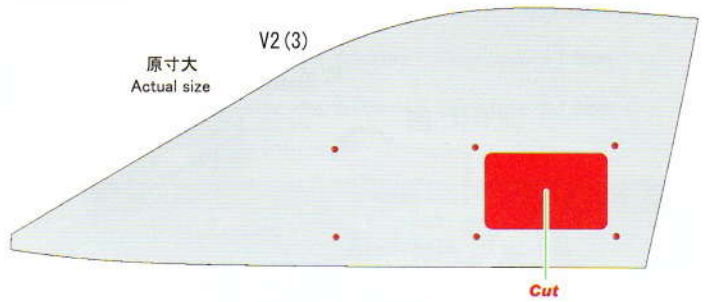

()内は反対側のパーツ番号です。
Numbers inside () are the opposite side parts number.
反対側も同様に取り付けます。
Please assemble the other side also as shown.

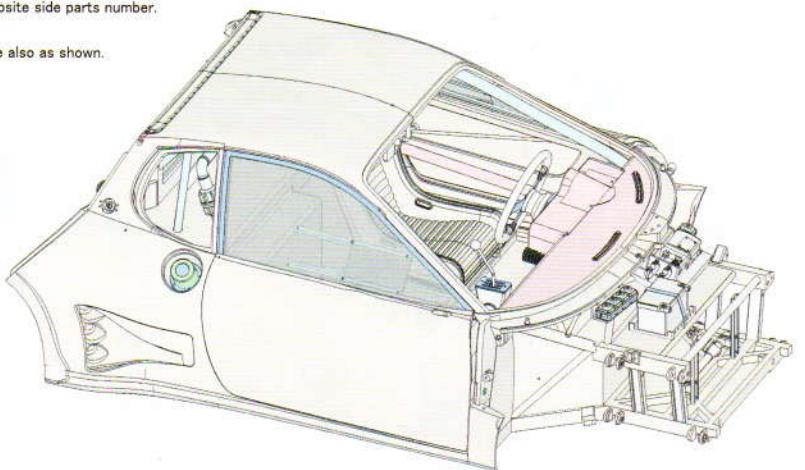
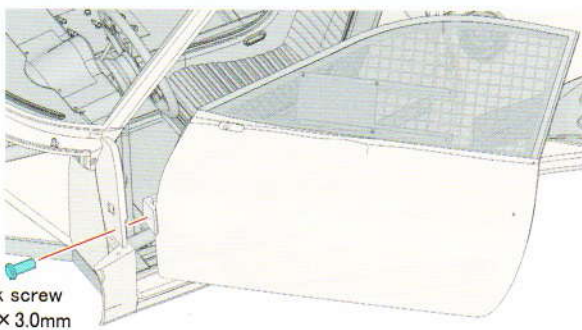
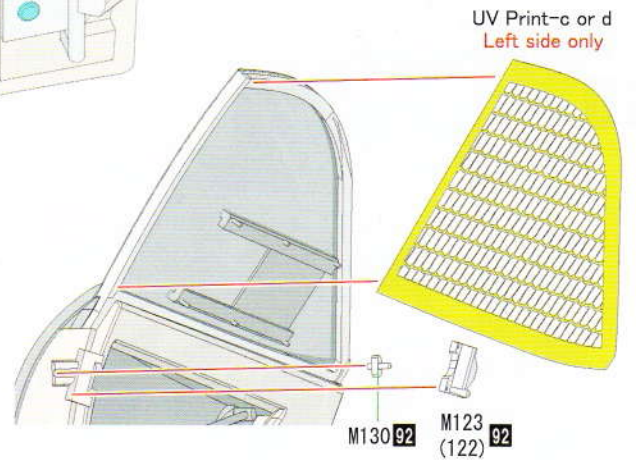
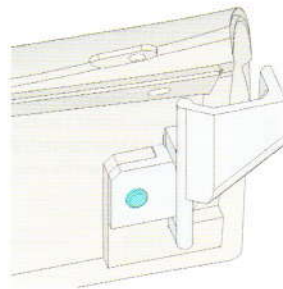

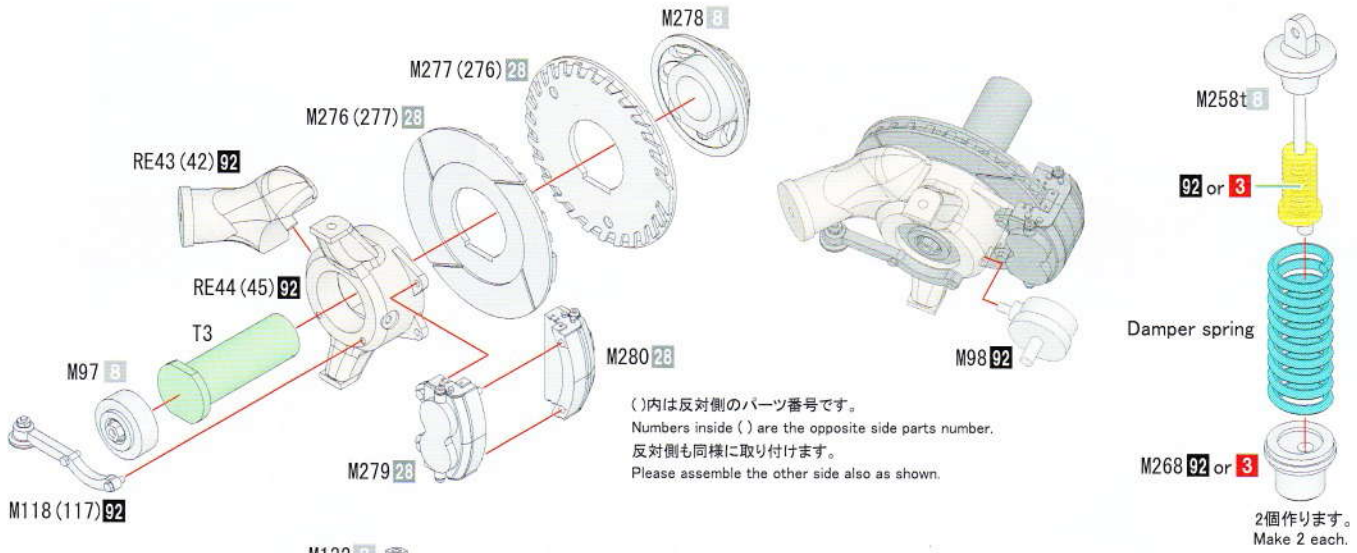

()内は反対側のパーツ番号です。
Numbers inside () are the opposite side parts number.
反対側も同様に取り付けます。
Please assemble the other side also as shown.

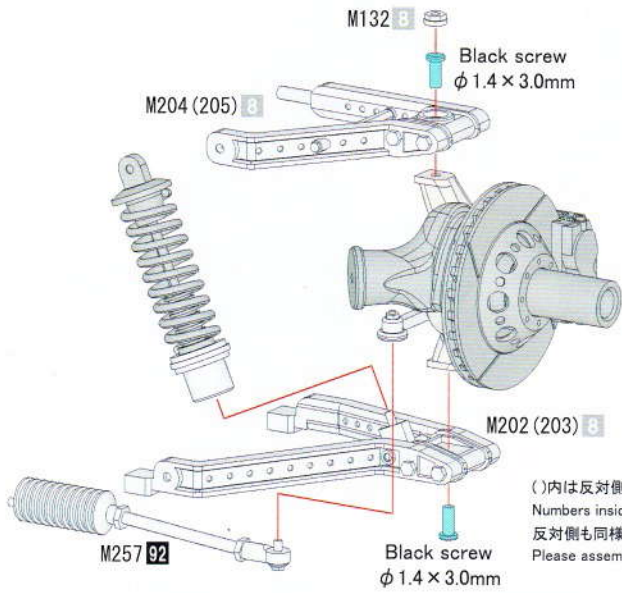

()内は反対側のパーツ番号です。
Numbers inside () are the opposite side parts number.
反対側も同様に取り付けます。
Please assemble the other side also as shown.

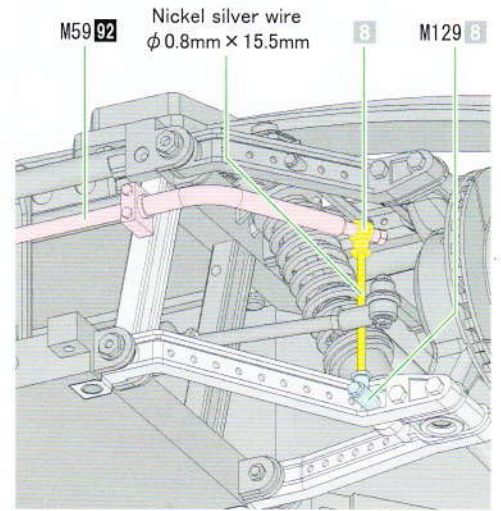
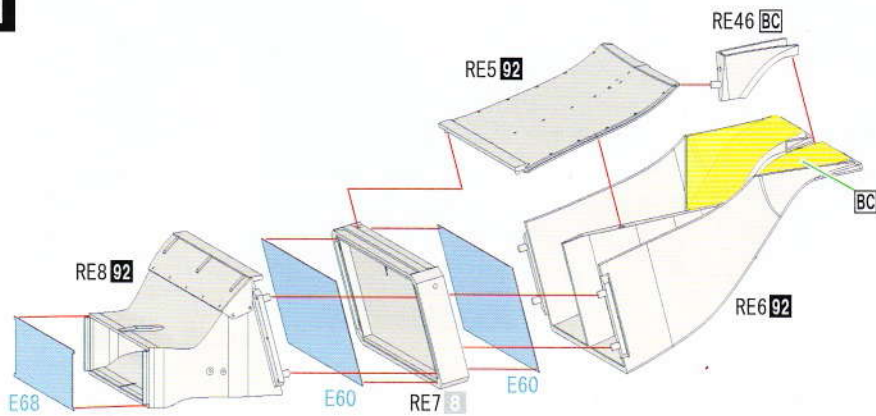
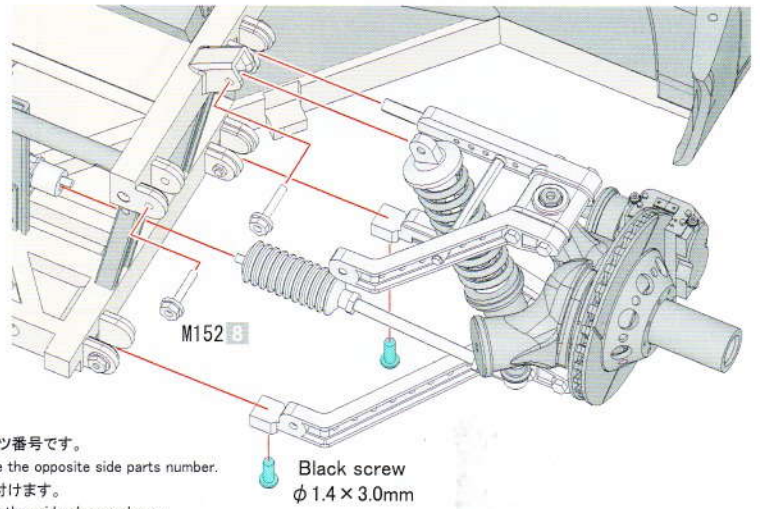

ver.D

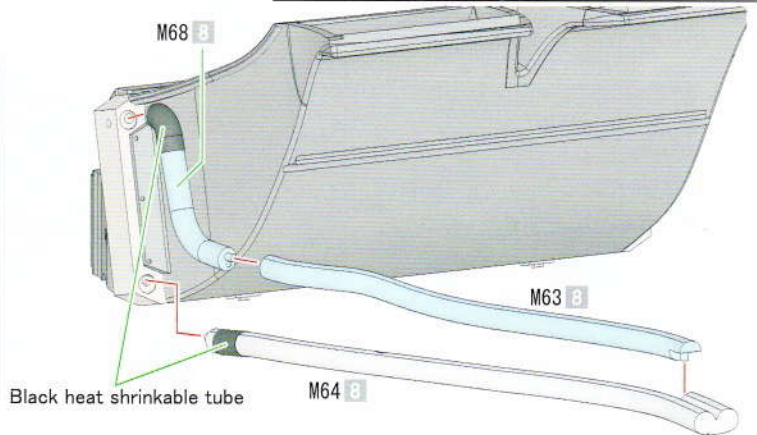
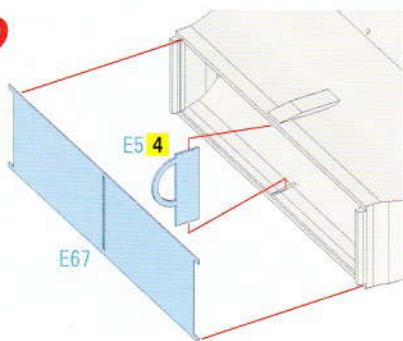

12

()内は反対側のパーツ番号です。
Numbers inside () are the opposite side parts number.

反対側も同様に取り付けます。
Please assemble the other side also as shown.

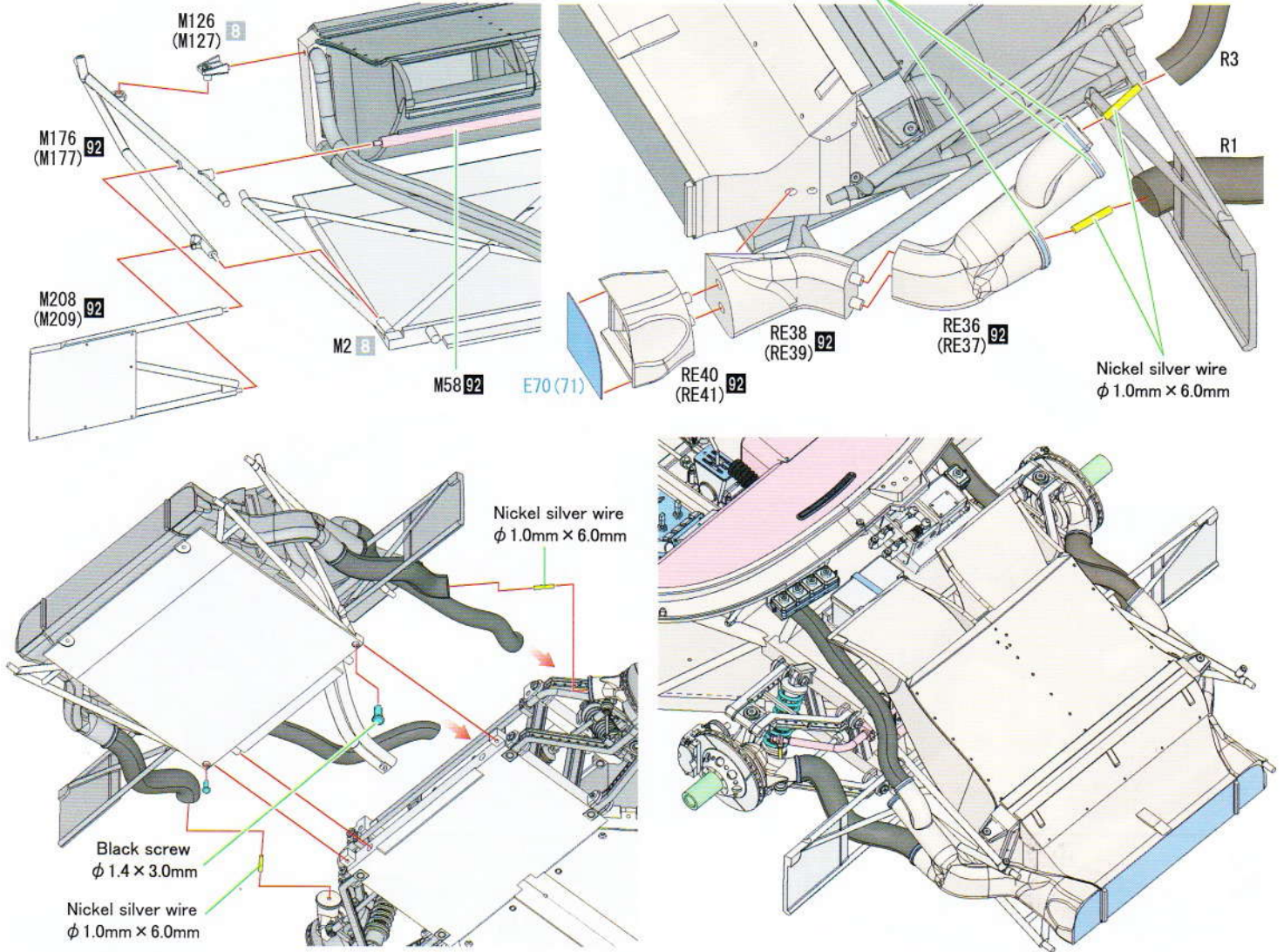

13

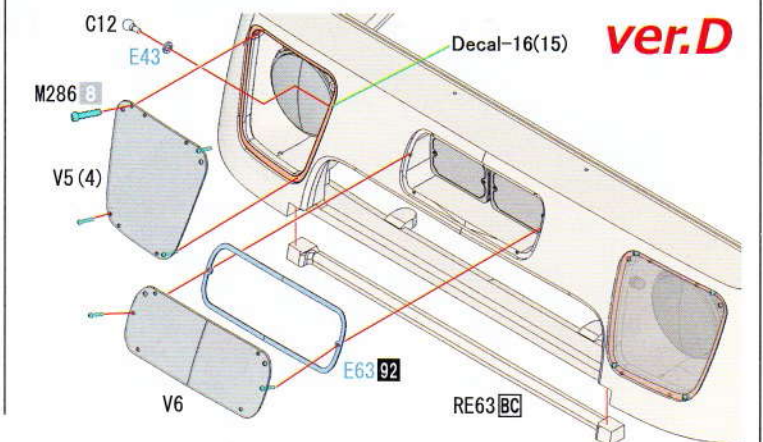
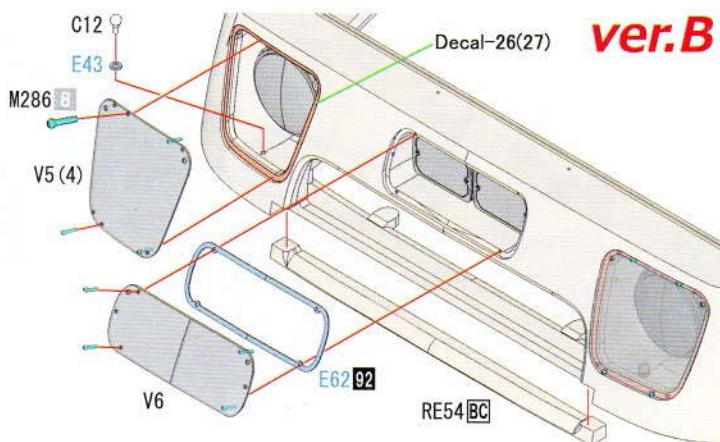
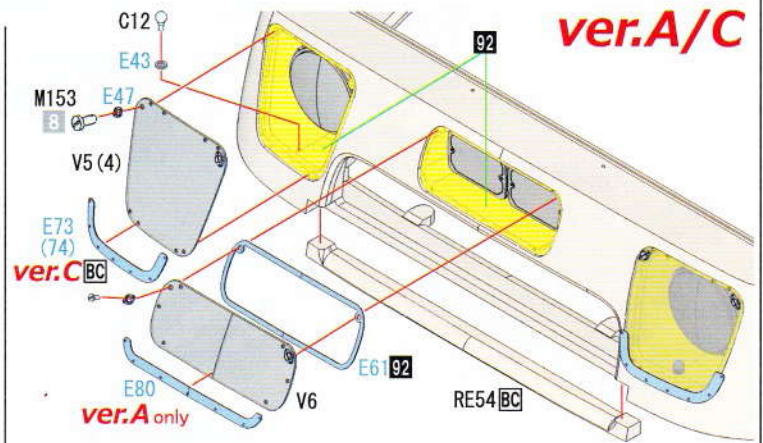
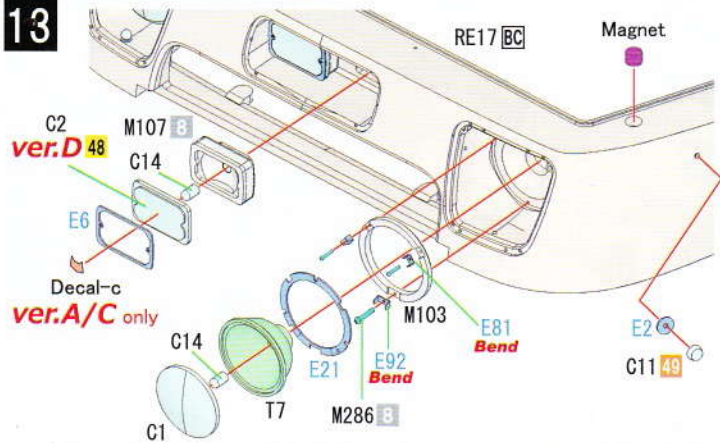

14

Black screw
φ 1.4 × 3.0mm

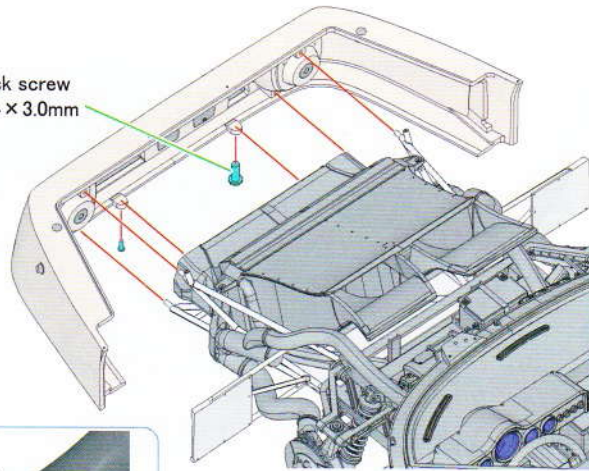

Nickel silver wire
φ 1.0mm × 6.0mm

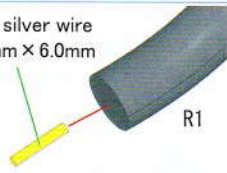

R1

R1

反対側も同様に取り付けます。
Please assemble the other side also as shown.
()内は反対側のパーツ番号です。
Numbers inside () are the opposite side parts number.

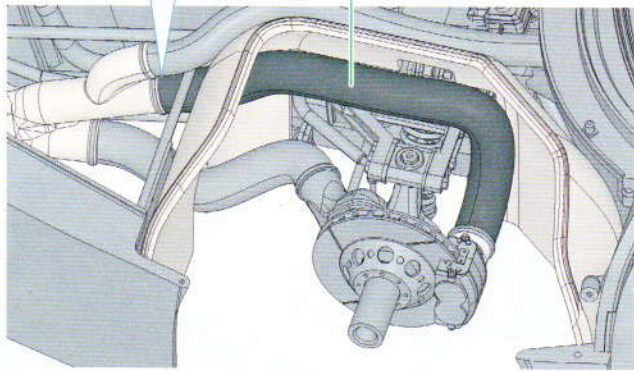

RE31 (RE30) 92

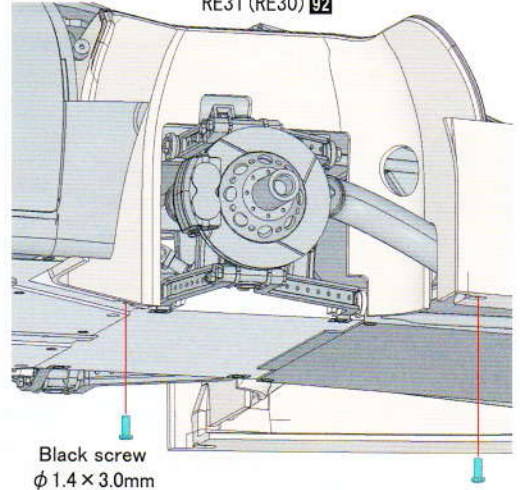

Black screw
φ 1.4 × 3.0mm

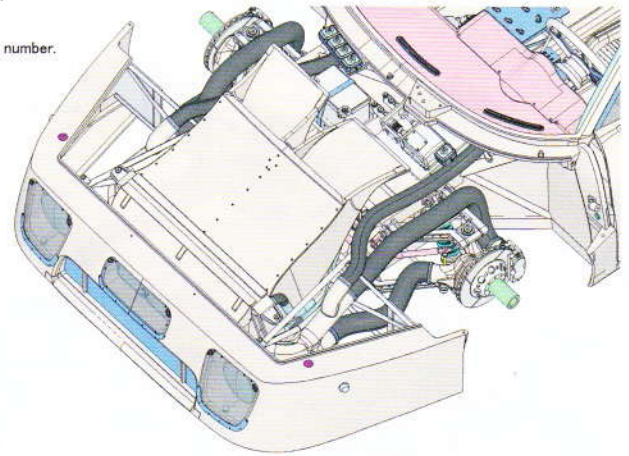

15

RE11 8

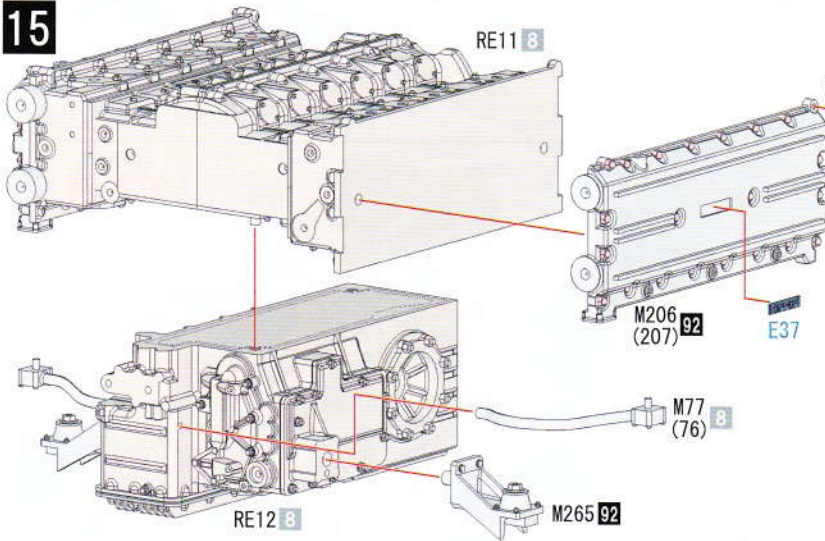

Left side

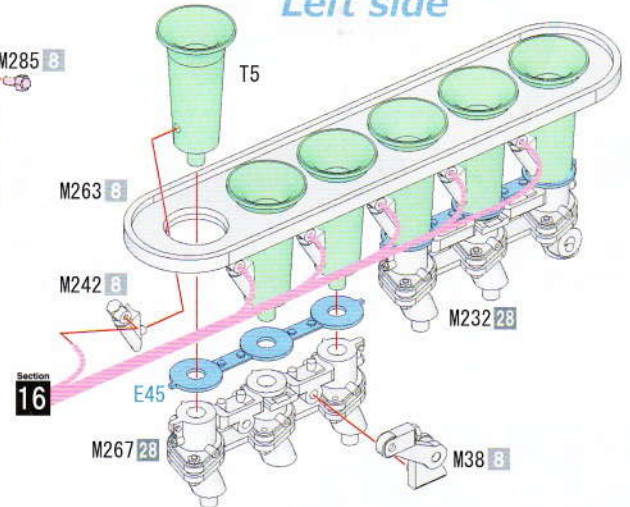

Section 16

Right side

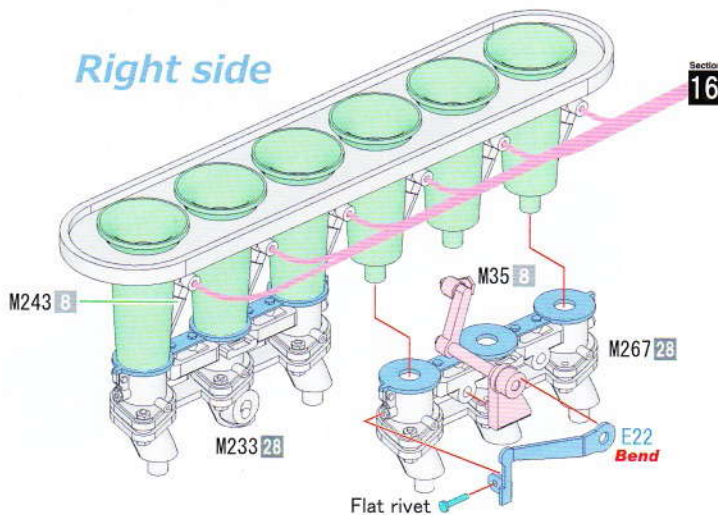

< Piping >

- Clear tube φ 0.6mm
- Black code φ 0.6mm

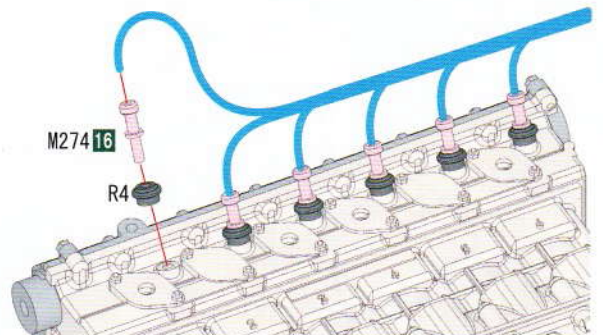

反対側も同様に取り付けます。
Please assemble the other side also as shown.

Section 16

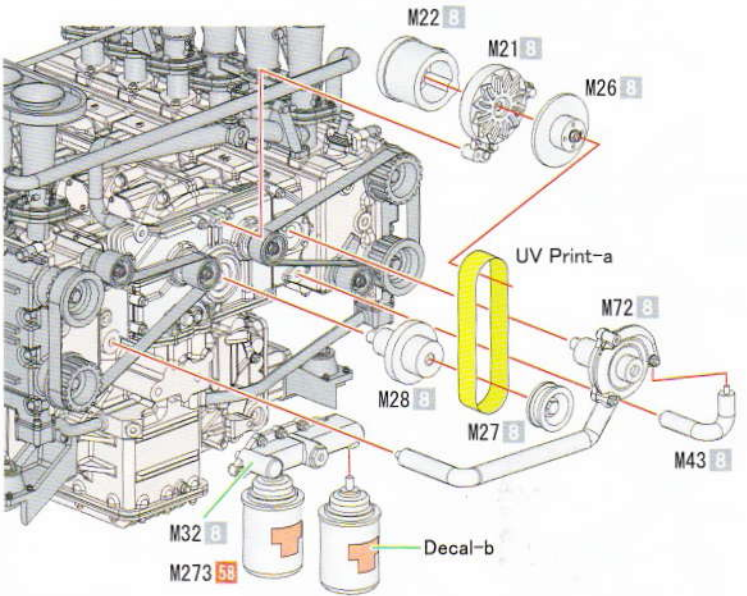
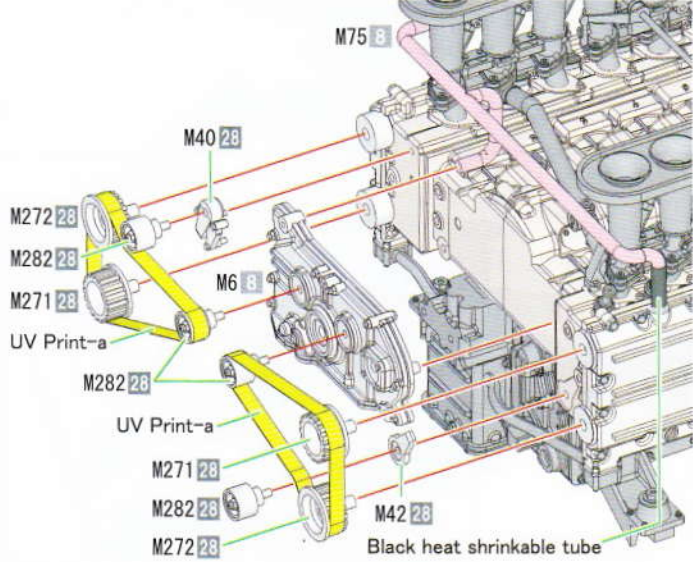
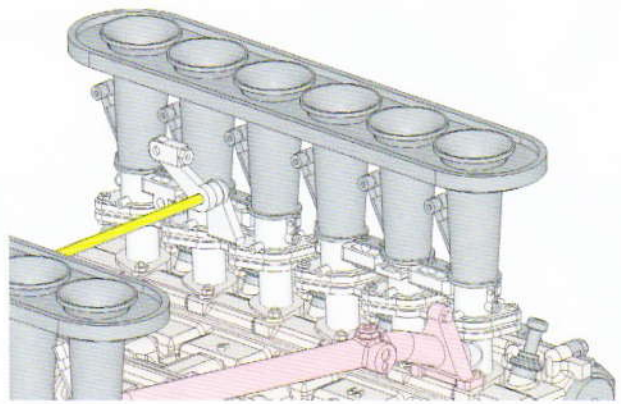
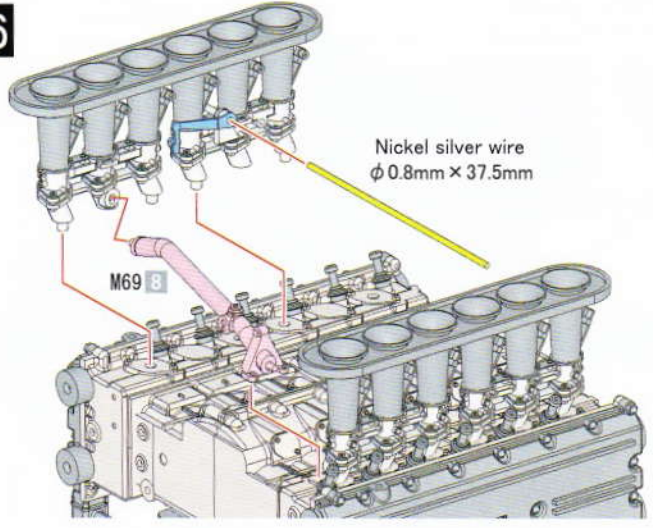

UV Print set UVプリントセット

UVプリントセットは、デカールの様に水に浸して台紙から剥がして使用して下さい。
 強く引っ張ったり、何度も折り曲げると破損の原因となります。
 after tightening UV Print set, use super glue on the head of the band to firmly secure it in place.
 clamping band may break/snap if too much force is exerted or if band is repeatedly twisted/pulled on.

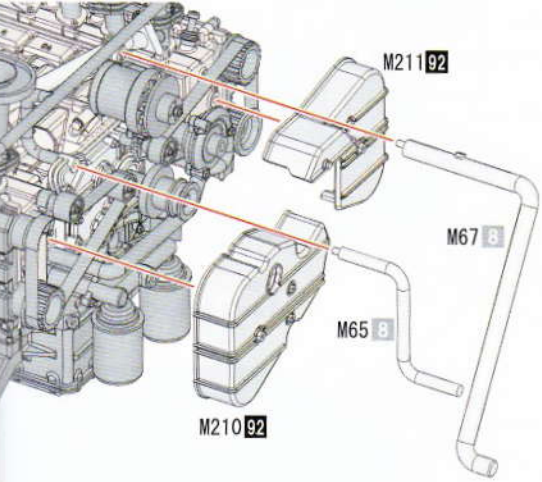

< Piping >
 Clear tube φ0.6mm
 Black code φ0.6mm

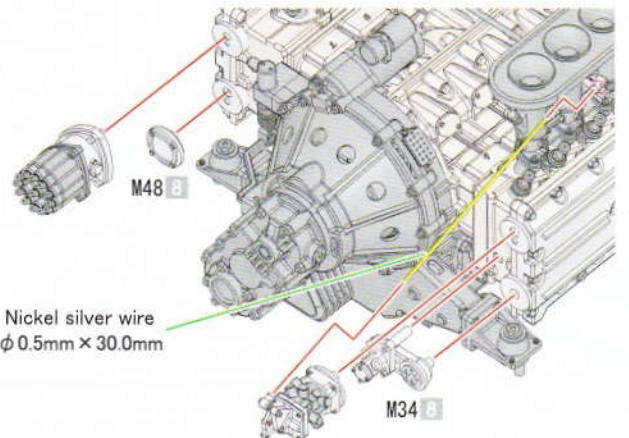
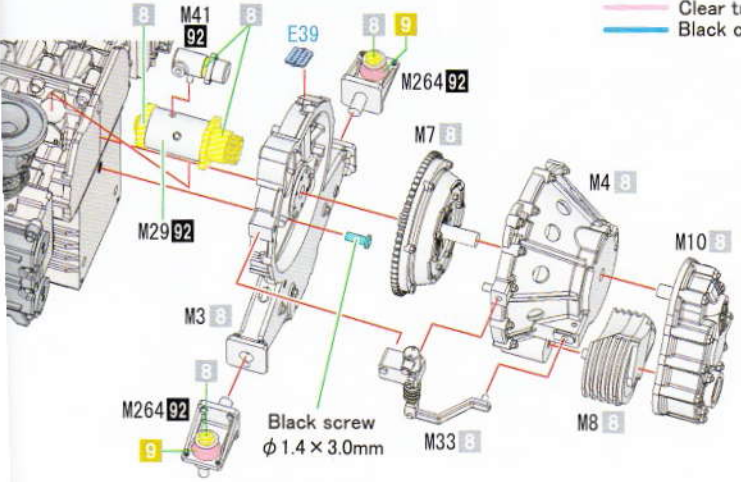
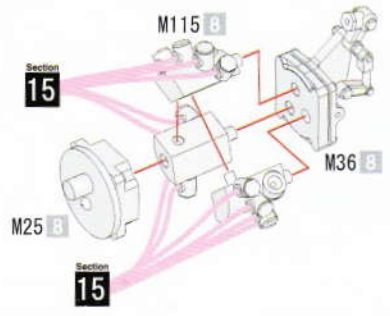

17

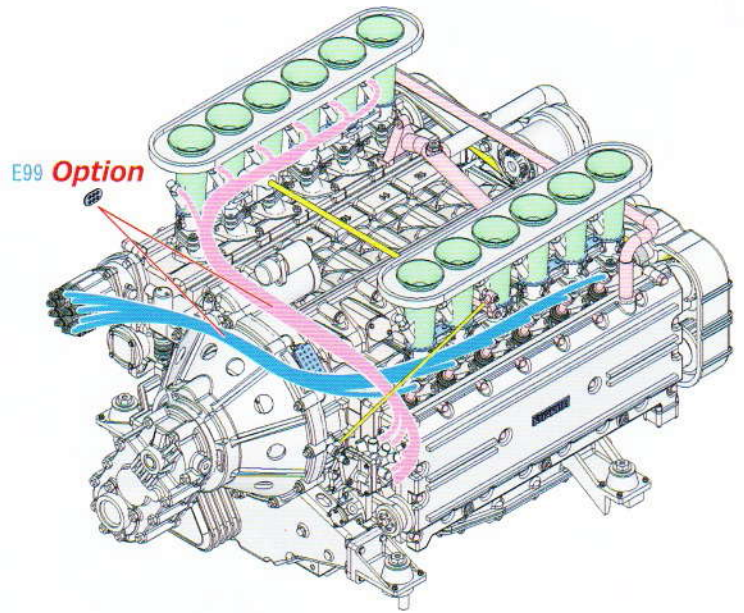
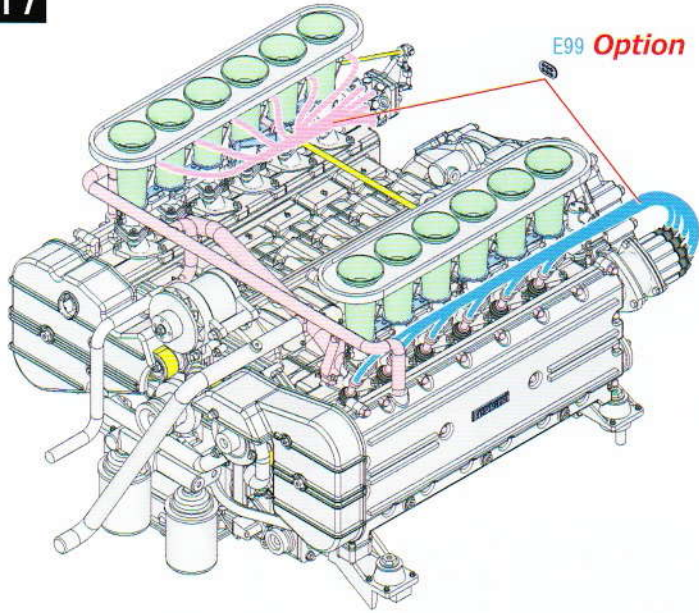

18

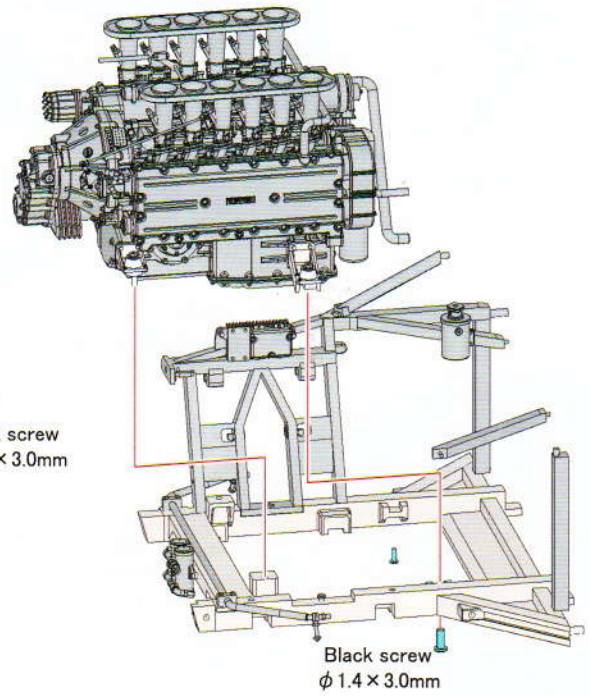
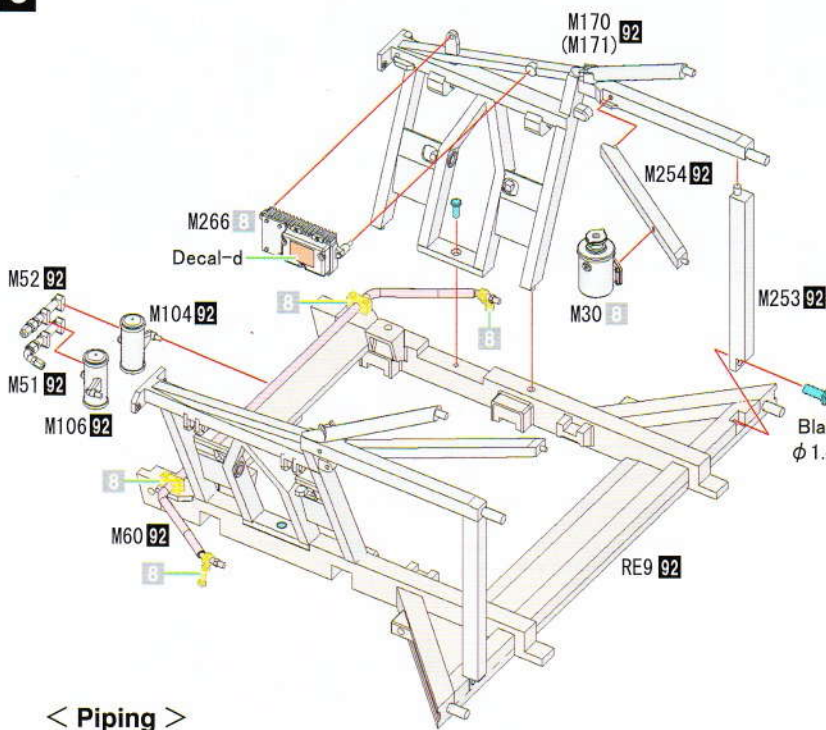

< Piping >

Nickel silver wire φ 0.5mm
+
Clear tube φ 1.1mm

2個作ります。
Make 2 each.

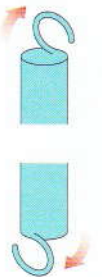

バネの両端を折り曲げてフック状にしてください。
Twist up ends of spring to form hooks.

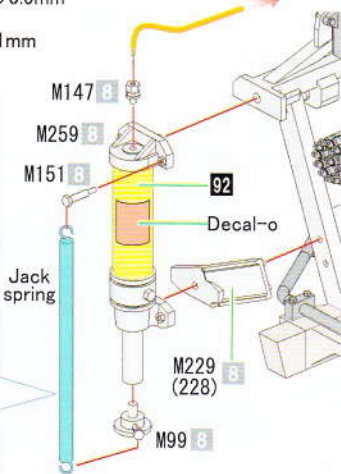

()内は反対側のパーツ番号です。
Numbers inside () are the opposite side parts number.
反対側も同様に取り付けます。
Please assemble the other side also as shown.

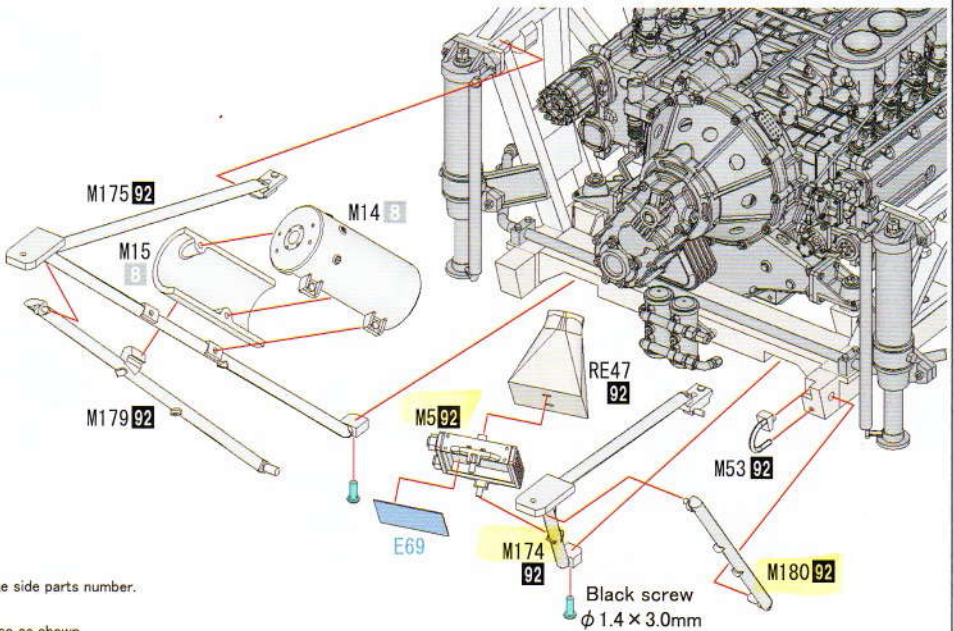

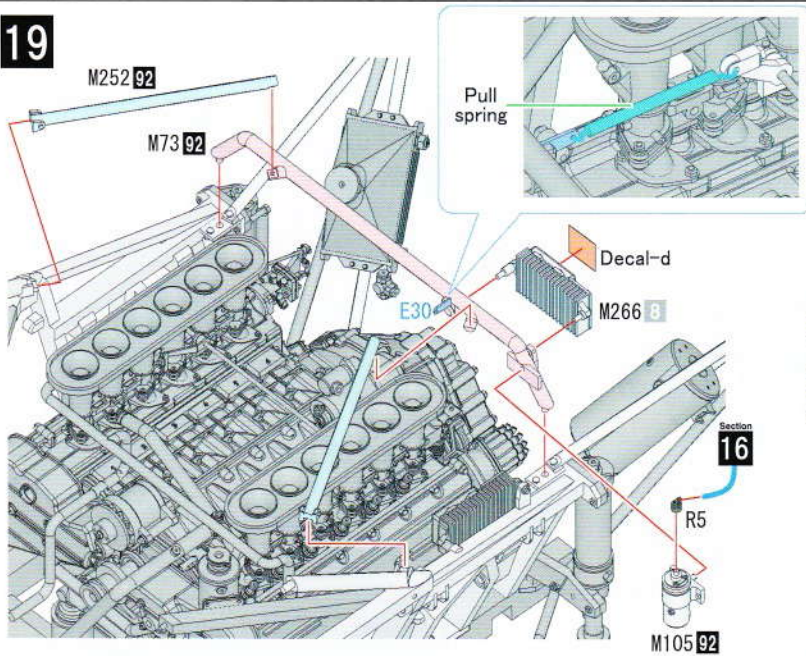

< Piping >

- Nickel silver wire $\phi 0.8\text{mm}$ + Red heat shrinkable tube
- Nickel silver wire $\phi 0.5\text{mm}$ + Clear tube $\phi 1.1\text{mm}$
- Nickel silver wire $\phi 0.5\text{mm}$ + Black tube $\phi 1.2\text{mm}$

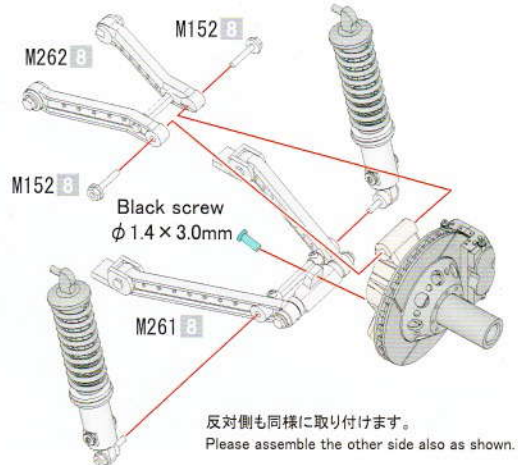
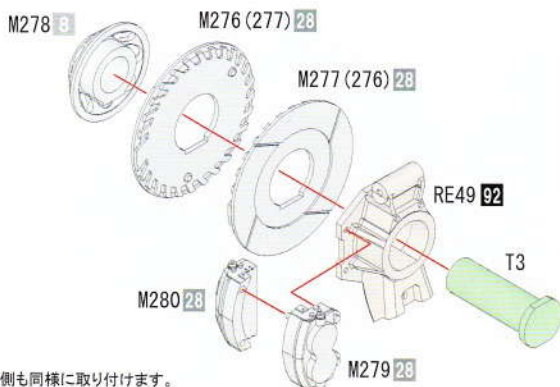
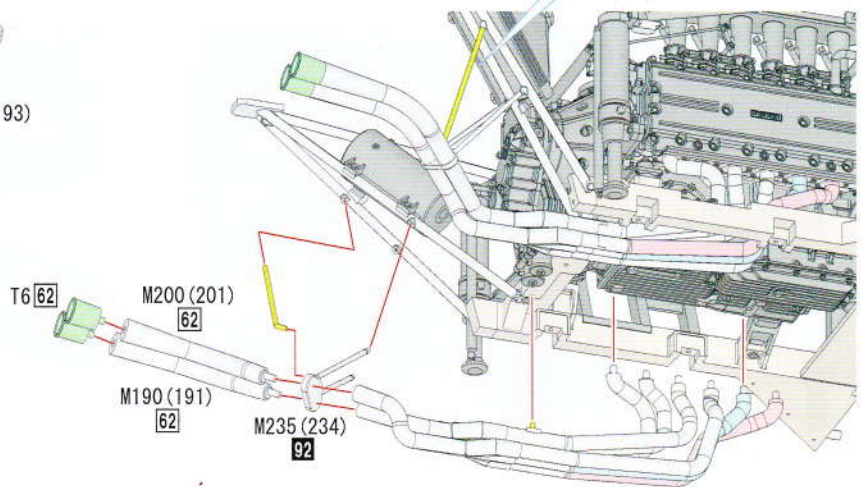
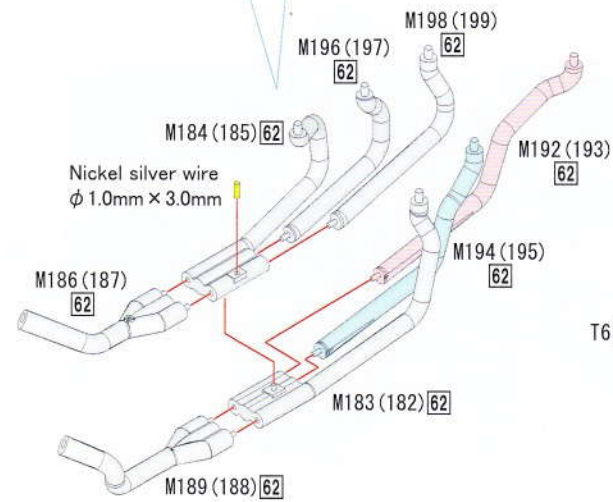
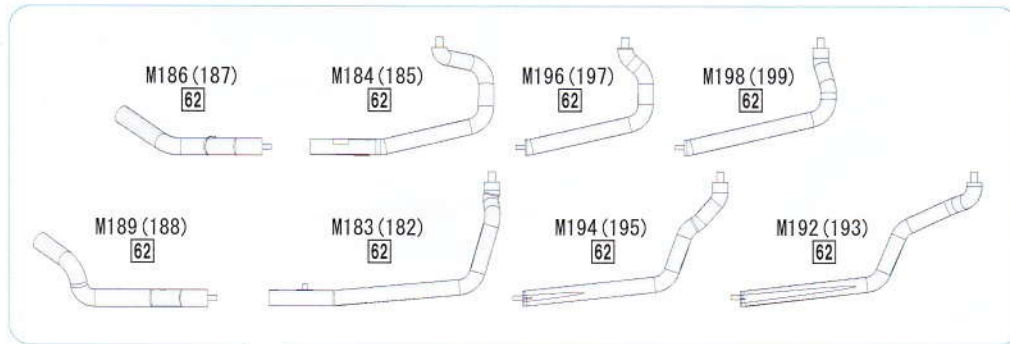
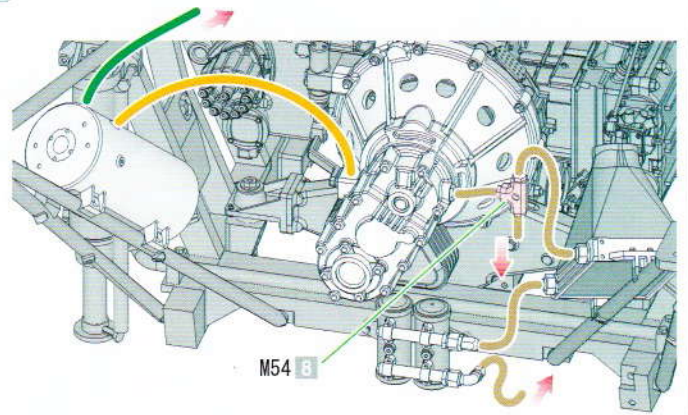

反対側も同様に取り付けます。
Please assemble the other side also as shown.
()内は反対側のパーツ番号です。
Numbers inside () are the opposite side parts number.

反対側も同様に取り付けます。
Please assemble the other side also as shown.

反対側も同様に取り付けます。
Please assemble the other side also as shown.

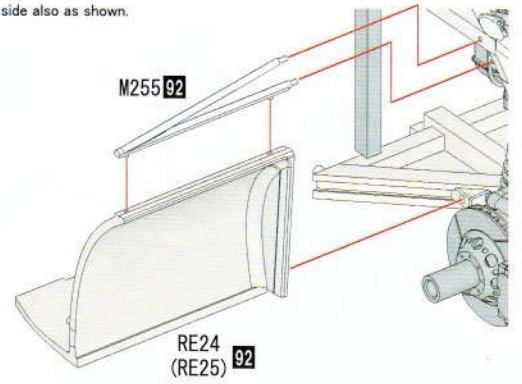
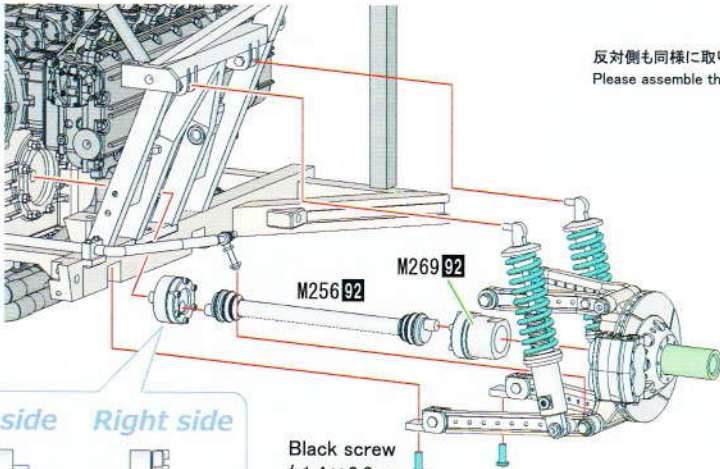

Left side Right side



M241 92

M240 92

Black screw
φ 1.4 × 3.0mm

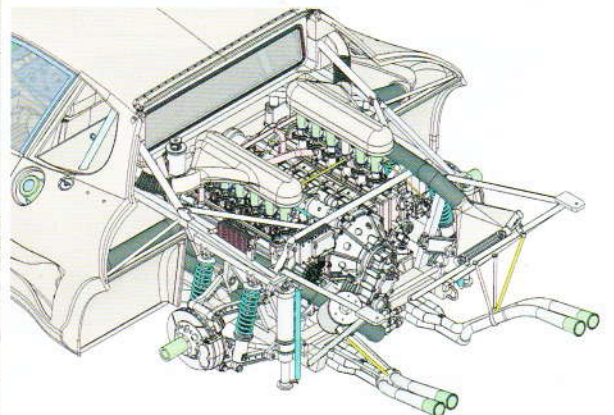
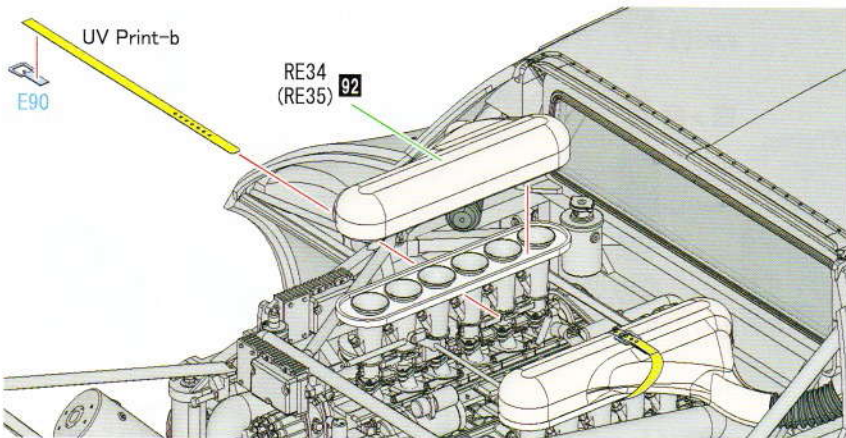
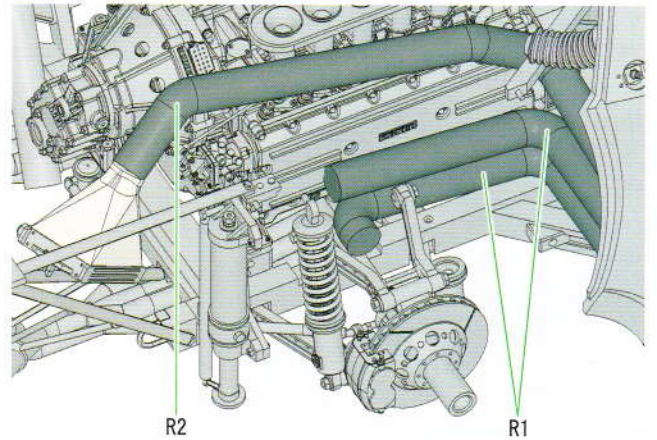
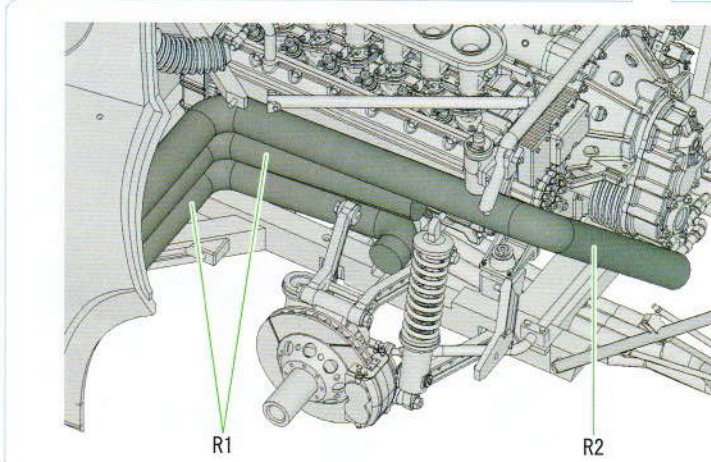
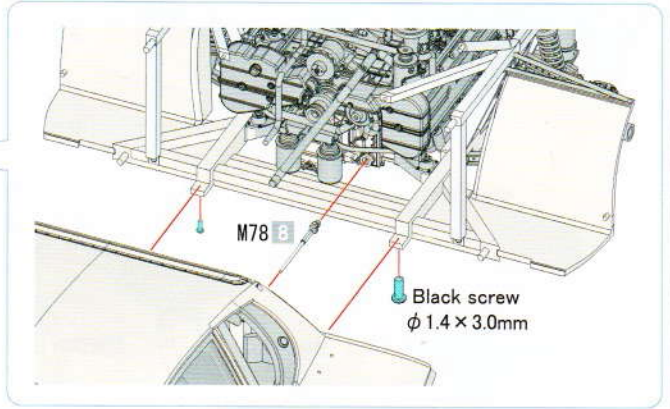
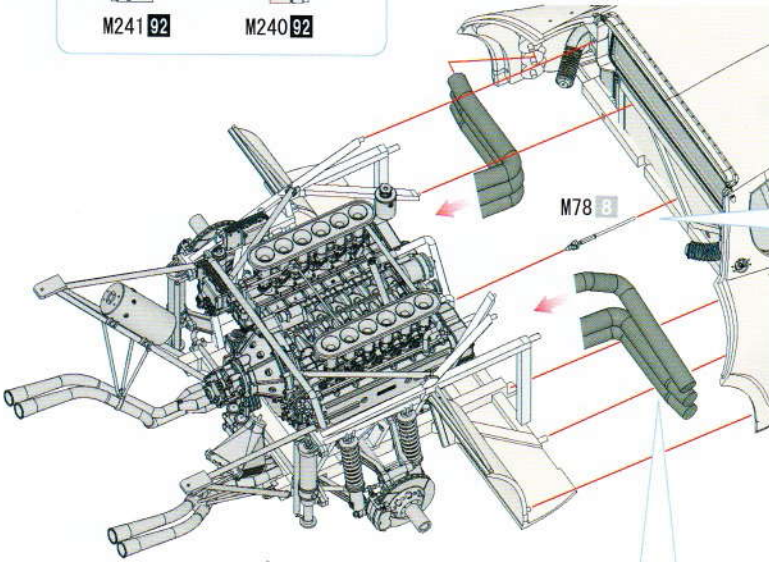

21

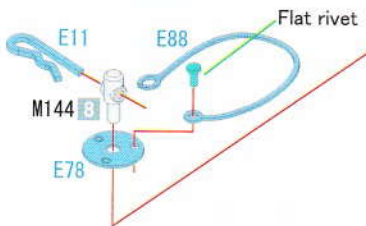
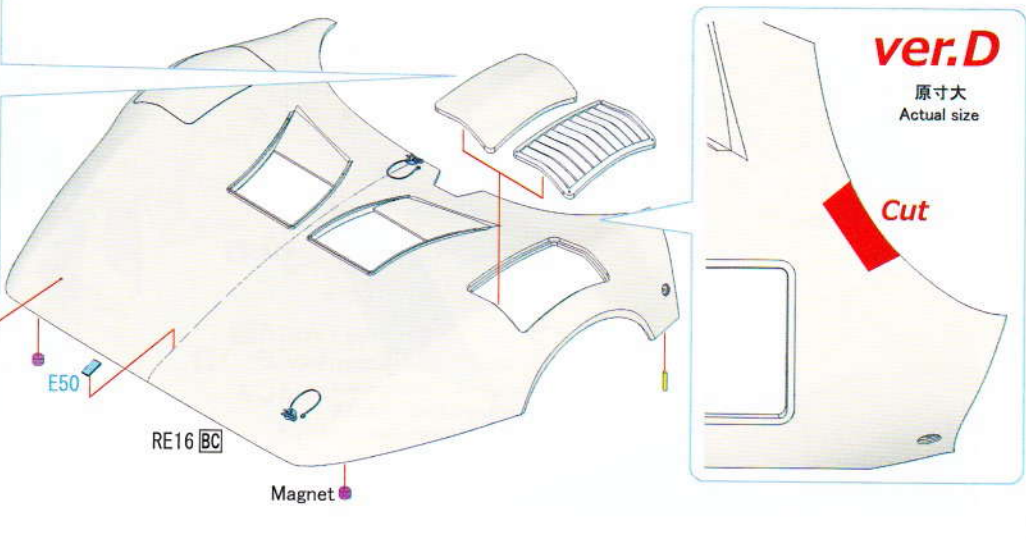
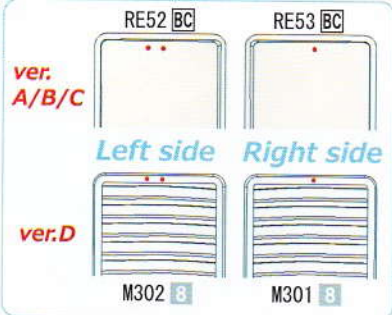

22

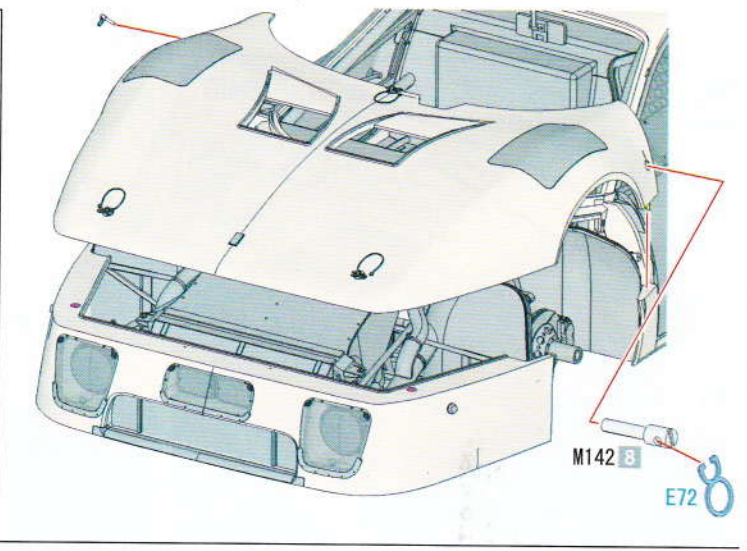
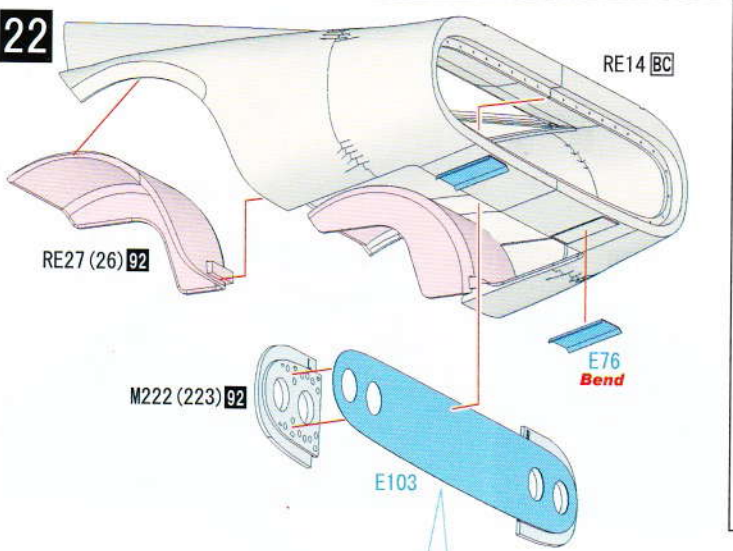

ver.A #62

Cutting sheet for masking



E103を黒で塗りつぶし、カッティングシートを使いマスキングをして、再度塗装してください。
 Please paint black and white.

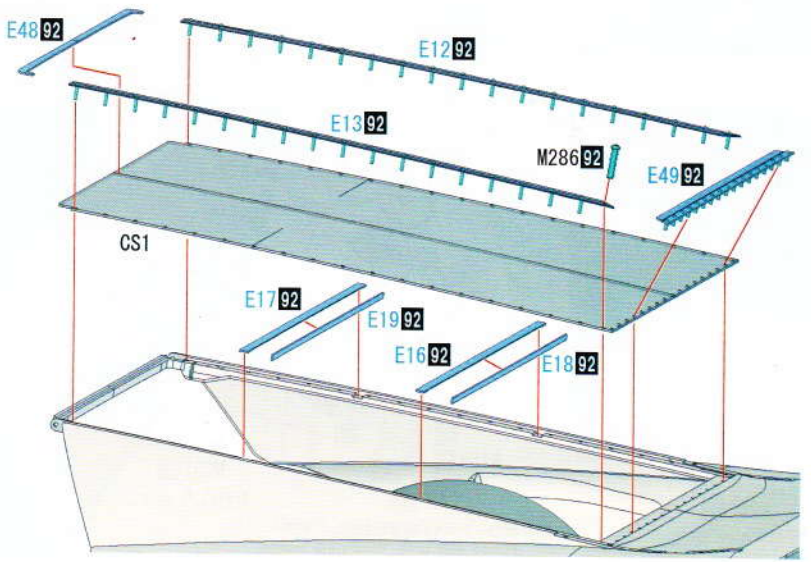
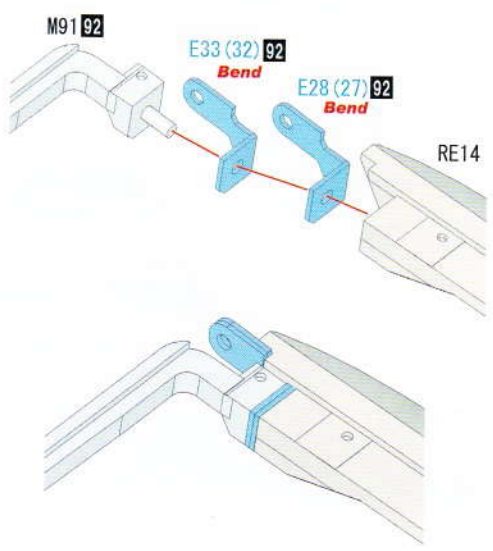
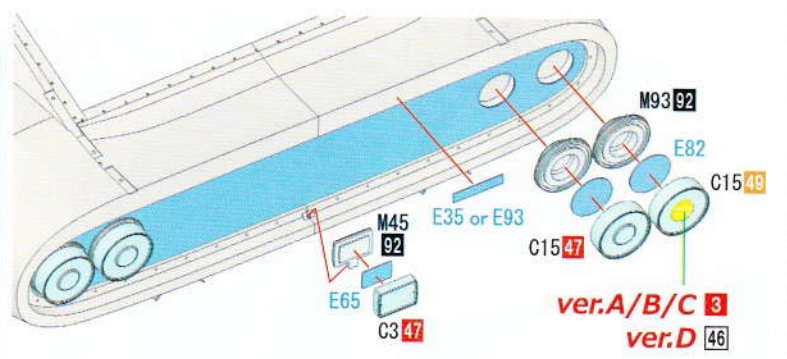

23

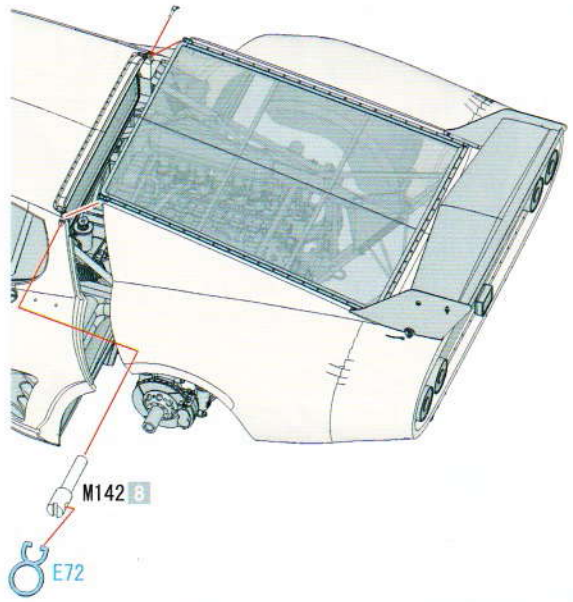
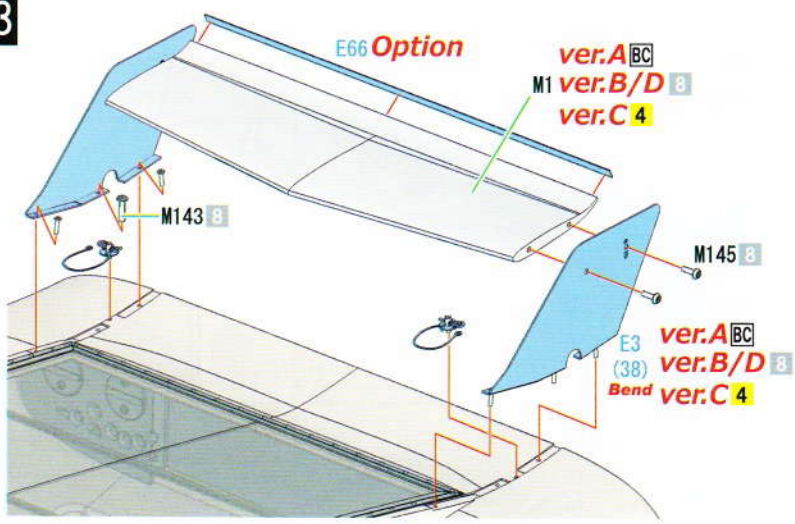

24

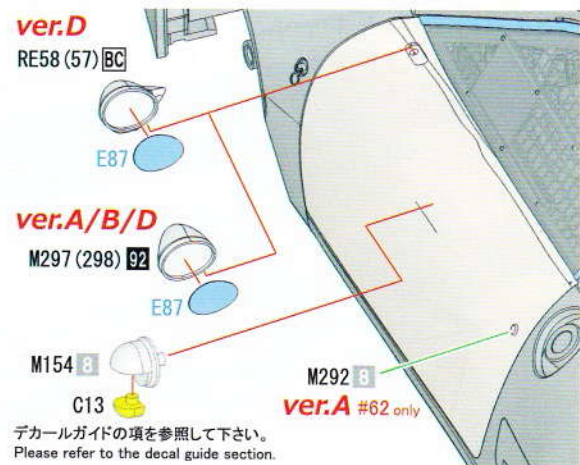
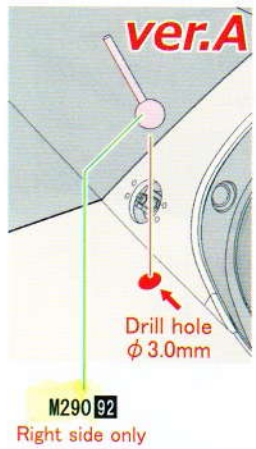
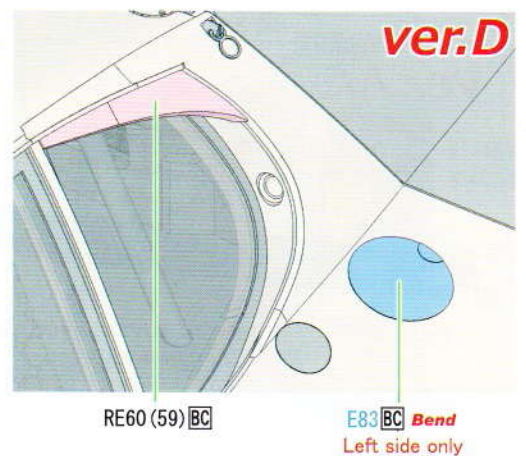
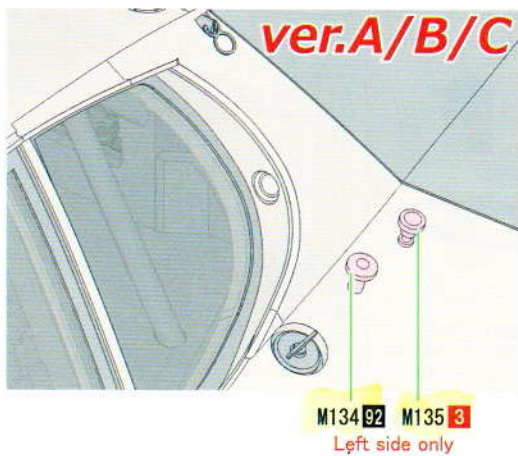
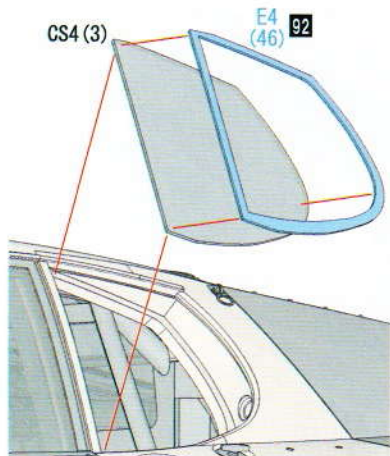
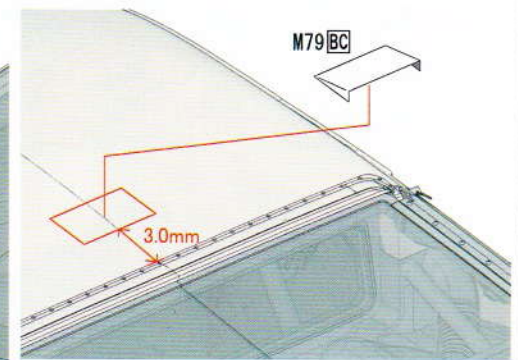
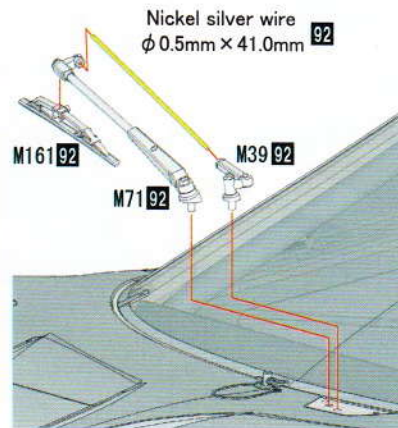
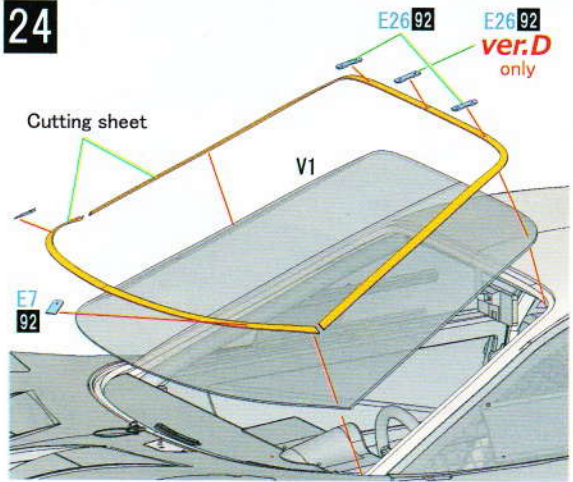

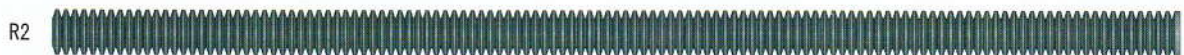
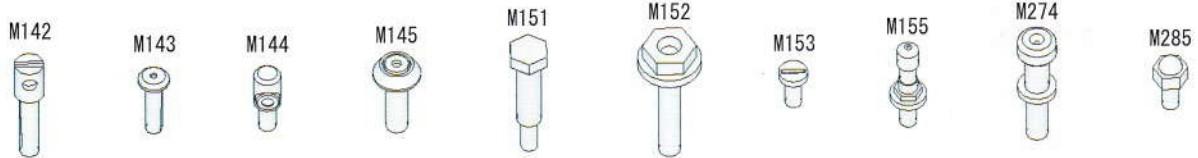
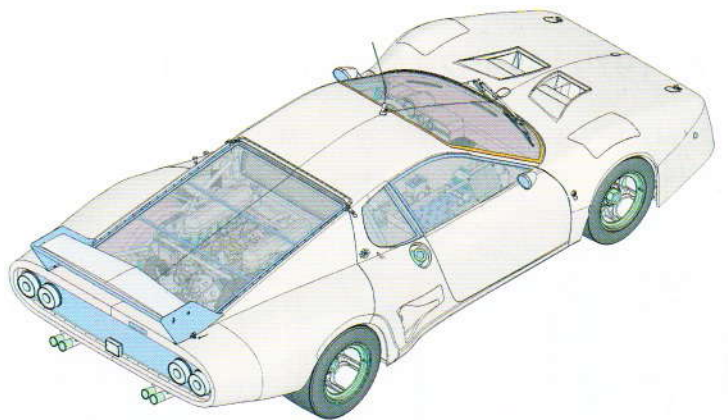
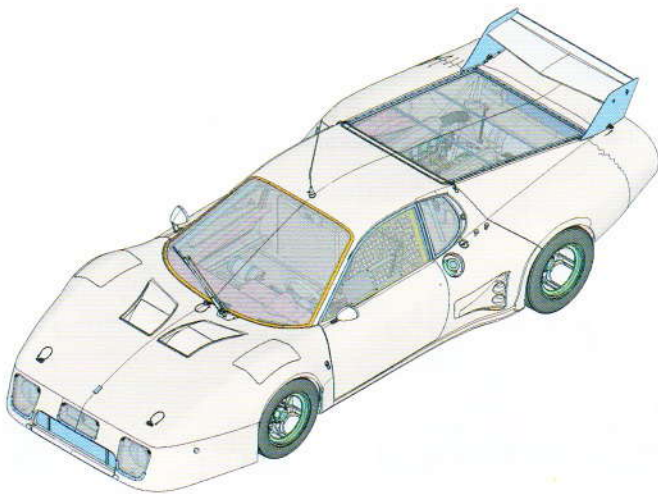
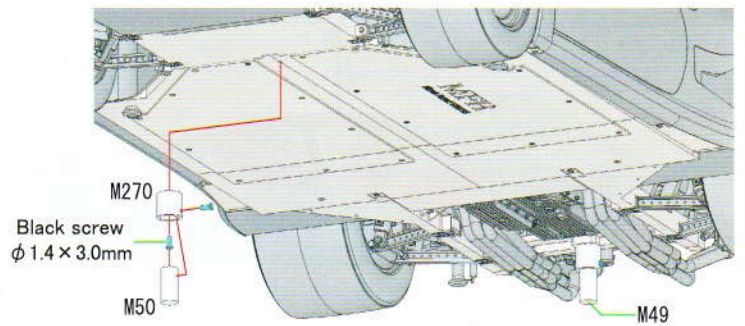
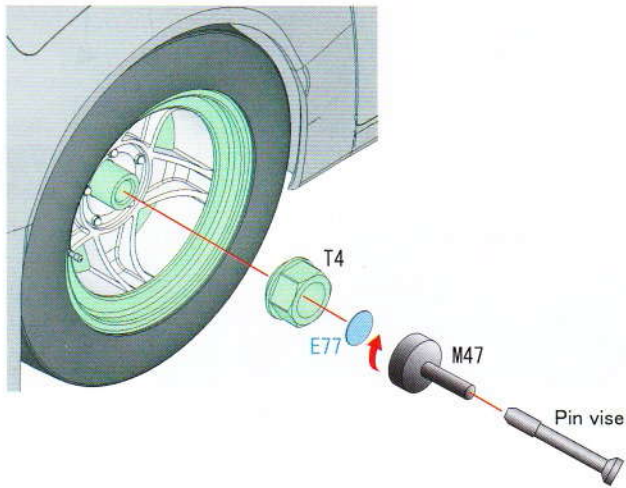
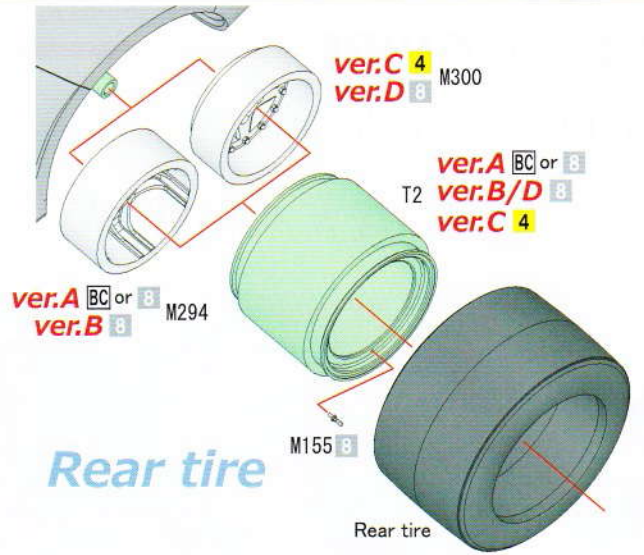
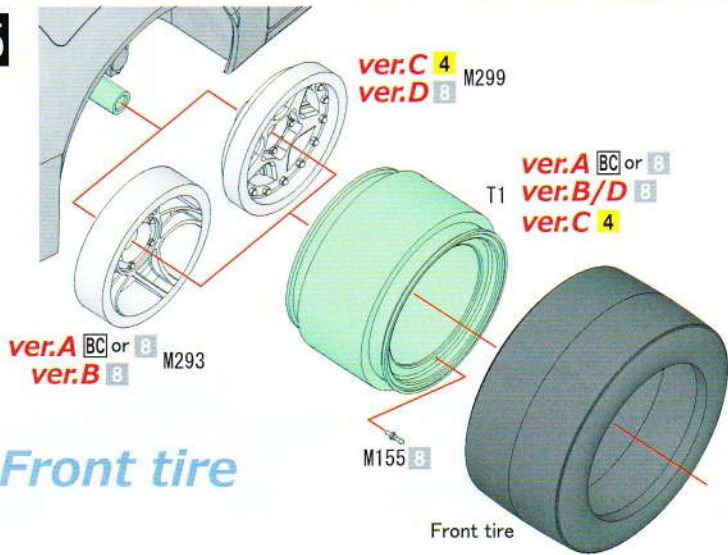

形状が解りづらいパーツの判別にお使い下さい。
Please use to determine the parts confusing shape.

DECAL GUIDE

Ver.A Base coloring

()内は反対側のデカール番号です。
Numbers inside () are the opposite decal number.

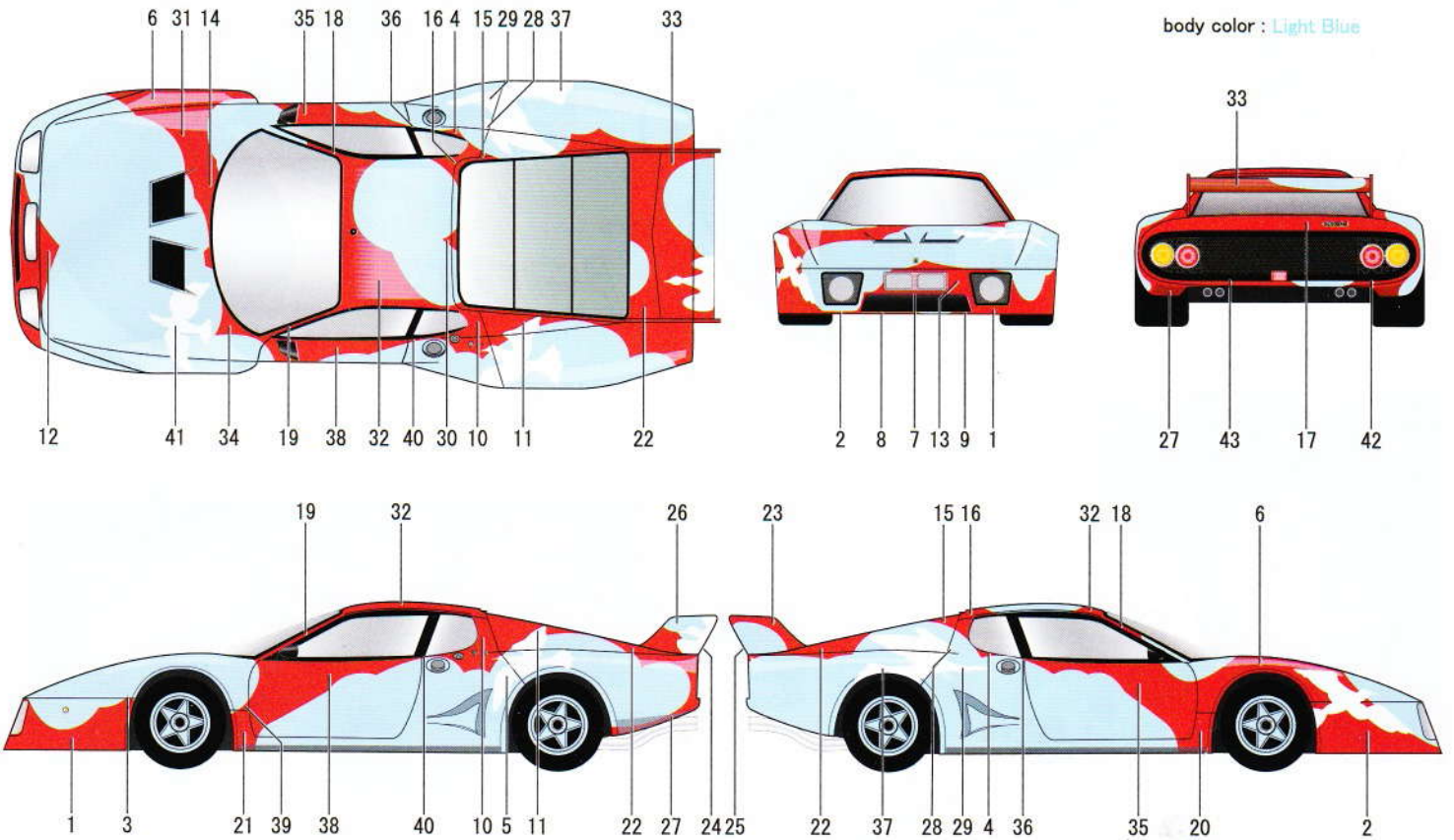

Ver.A : 1979 LM #62 J.C.Andruet / S.Dini

()内は反対側のデカール番号です。
Numbers inside () are the opposite decal number.

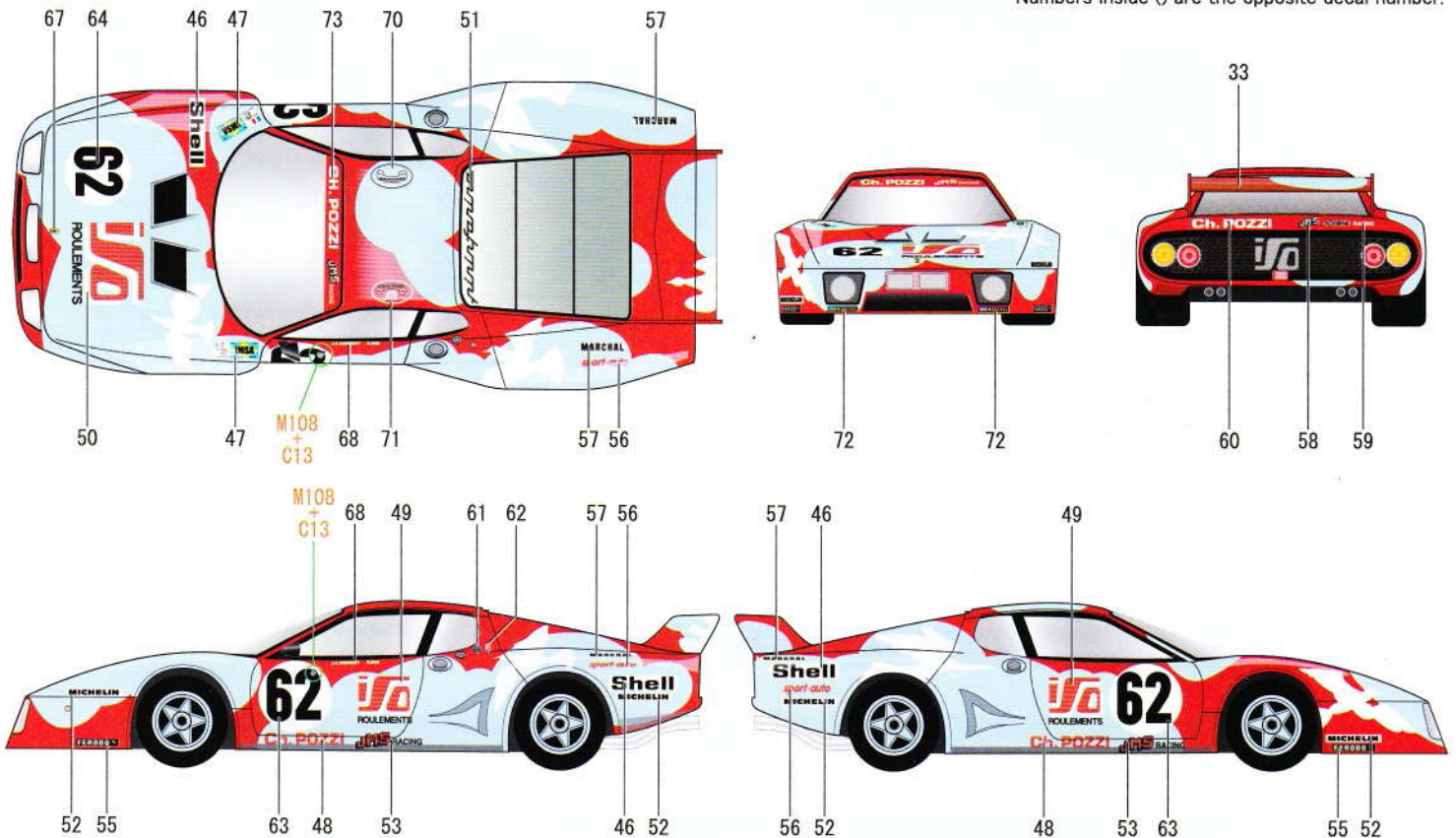

DECAL GUIDE

MFH

Model Factory Hiro

Ver.A : 1979 LM #63 C.B.Léna / M.Leclère / P.Gregg

()内は反対側のデカール番号です。
Numbers inside () are the opposite decal number.

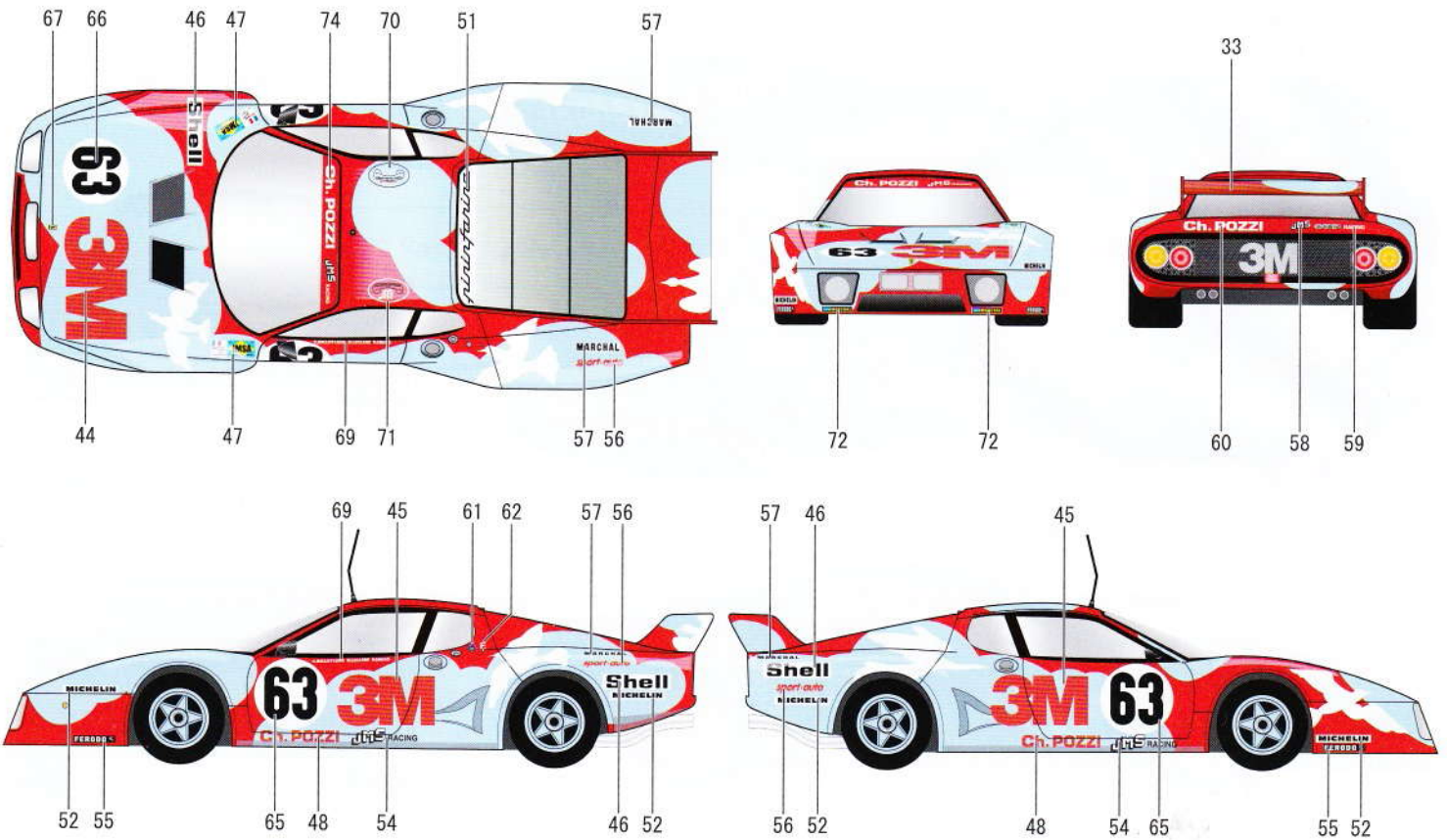

Ver.B : 1979 LM #64 J.P.Delaunay / C.Grandet / P.Henn

()内は反対側のデカール番号です。
Numbers inside () are the opposite decal number.

body color #158

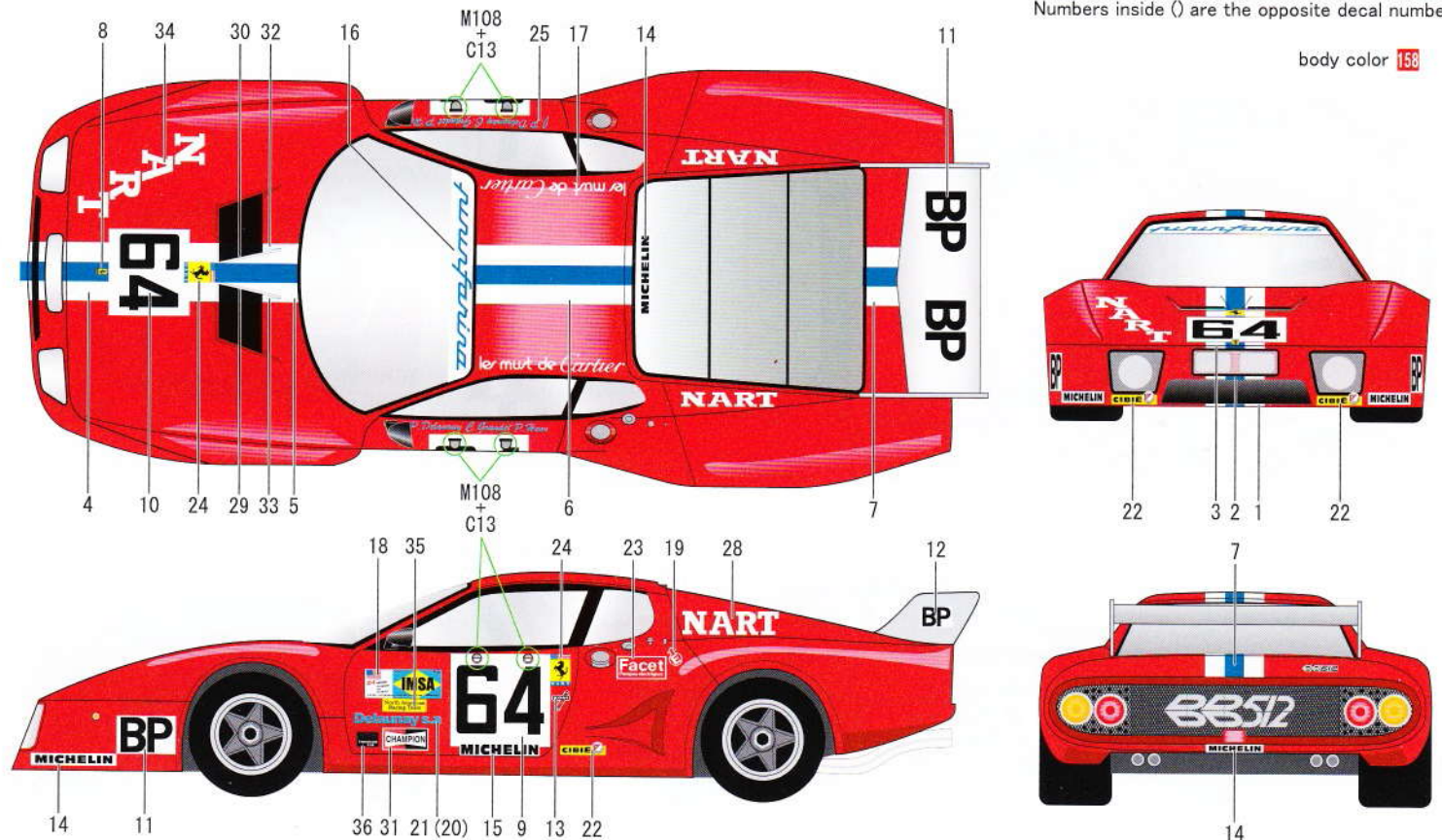

DECAL GUIDE

Ver.C : 1980 LM #75 L.Guitteny / G.Bleynie / J.P.Libert

()内は反対側のデカール番号です。
Numbers inside () are the opposite decal number.

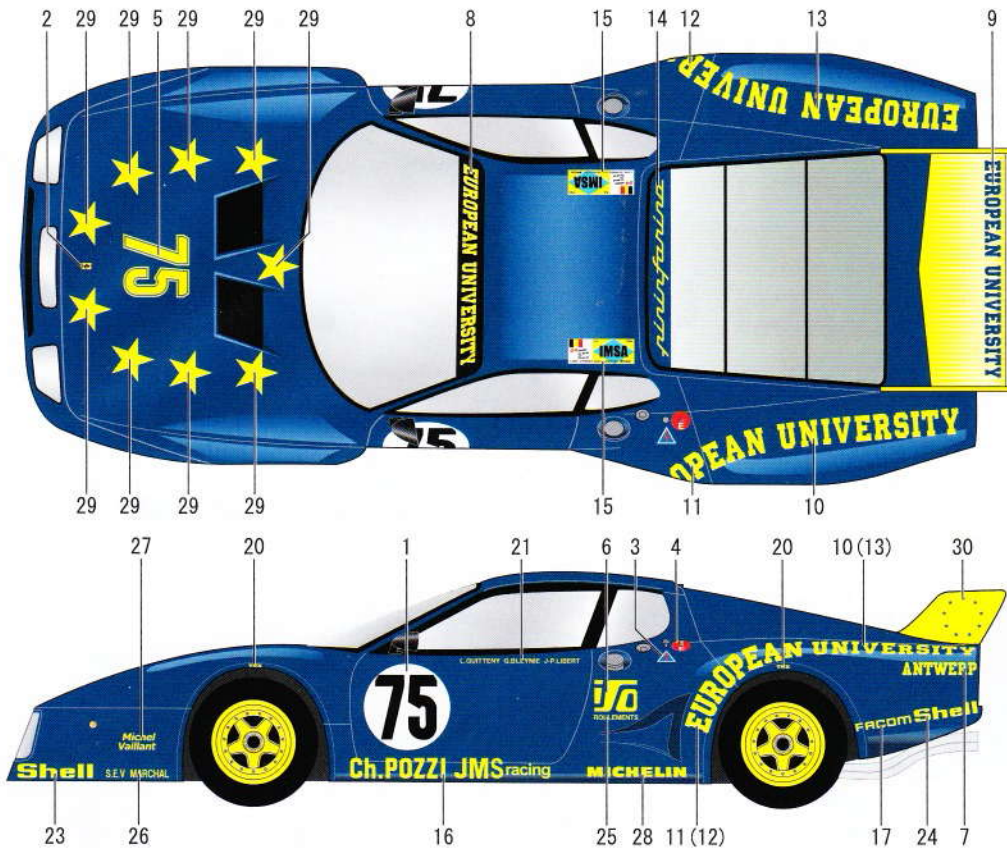

body color : Metallic Blue



Ver.D : 1980 LM #79 S.Dini / F.Violati / M.Micangeli

()内は反対側のデカール番号です。
Numbers inside () are the opposite decal number.

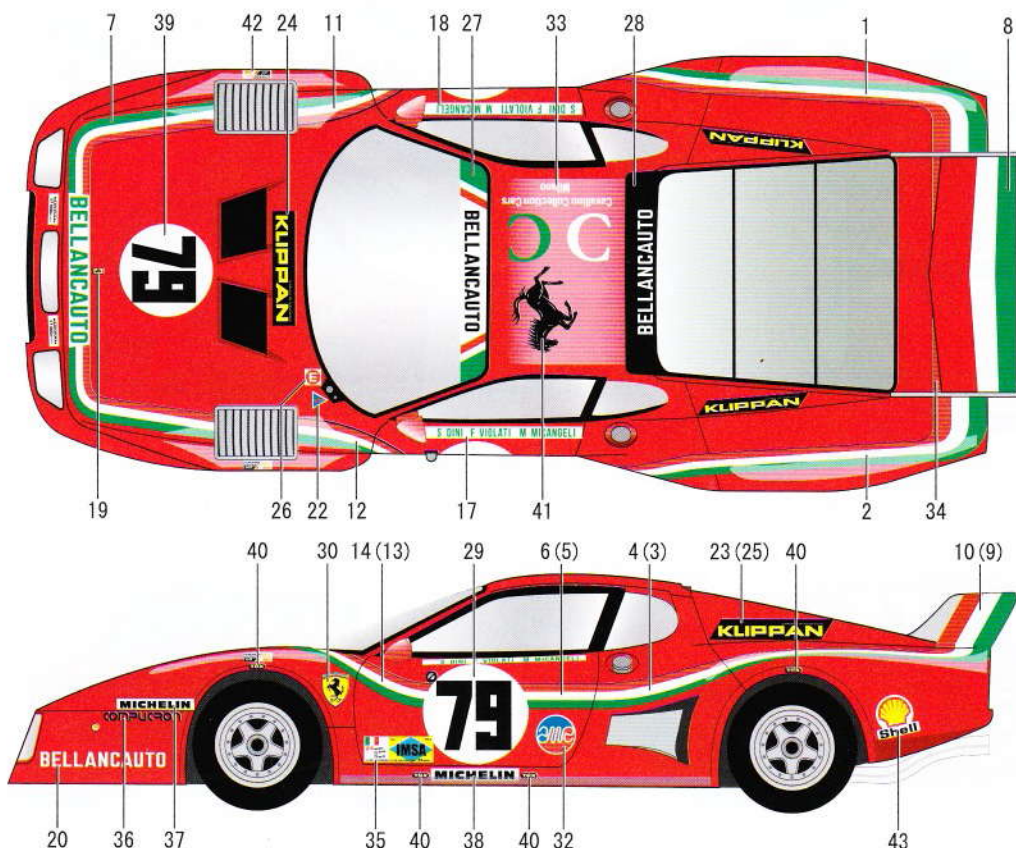

body color : 158



[Aluminium sheet guide]

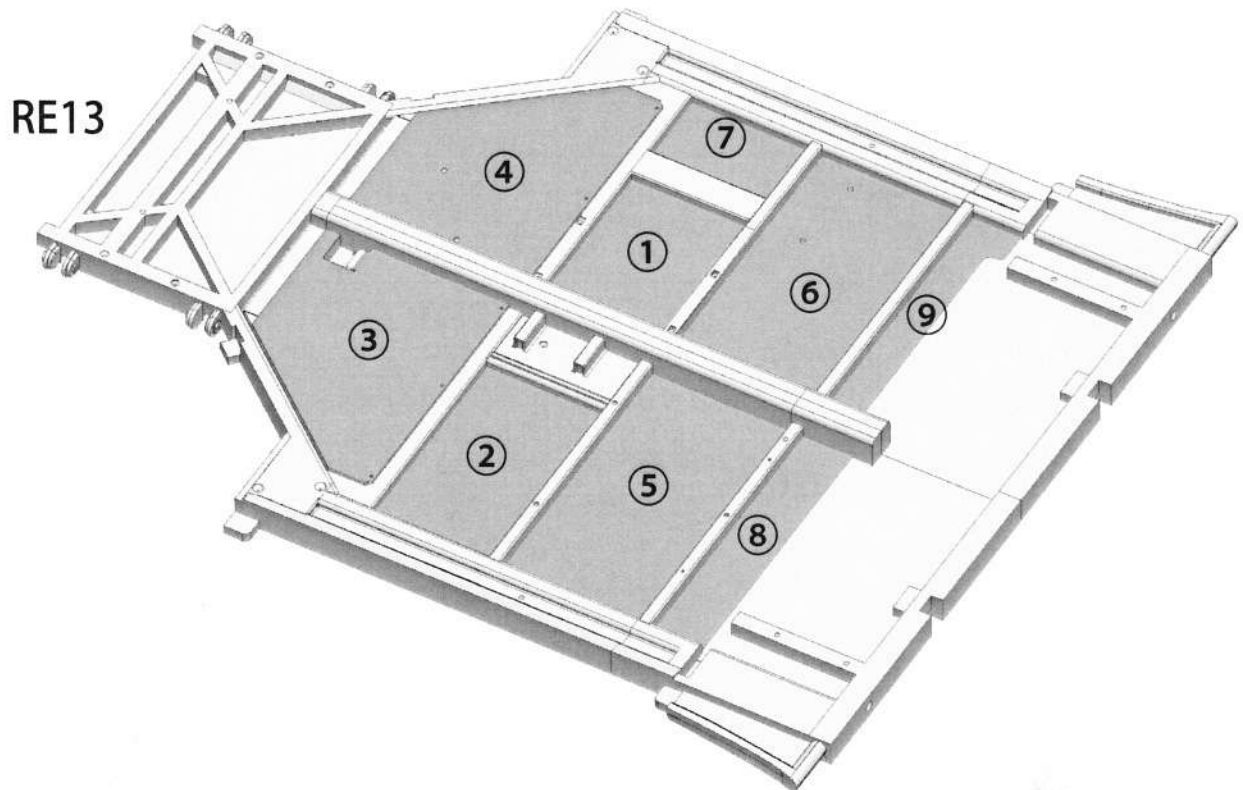

付属のアルミシートをカットする型紙としてコピーしてご利用ください。
Please use it as a cutting pattern of aluminium sheet.

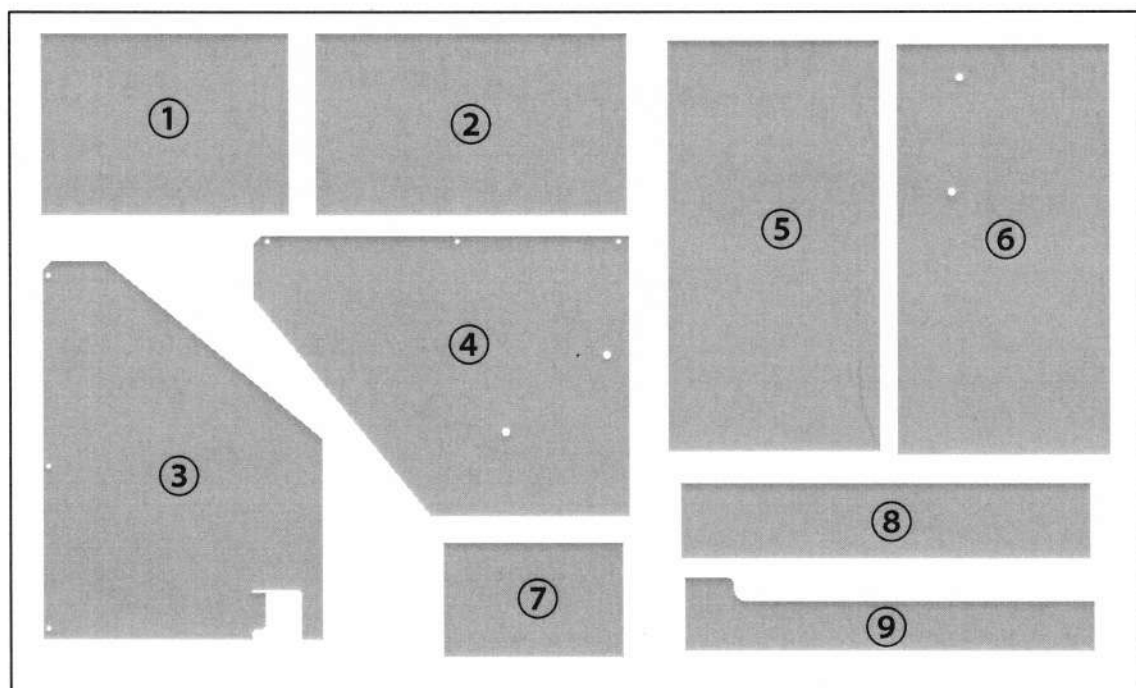

原寸大 Actual size

[Clear sheet guide]

付属のクリアシートをカットする型紙としてコピーしてご利用ください。
Please use it as a cutting pattern of clear sheet.

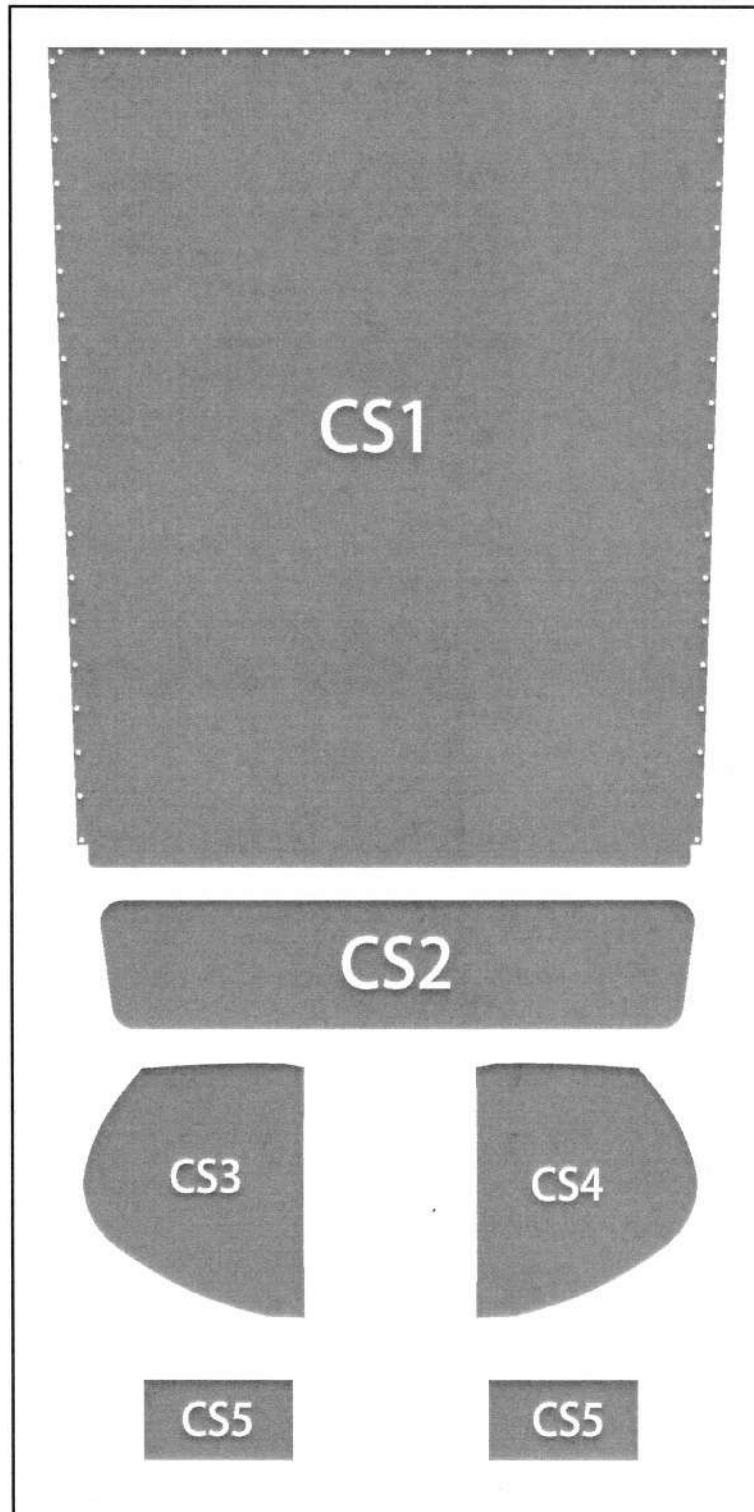

原寸大 Actual size