

1/12 scale Fulldetail Kit

Ferrari SF70H



Ver.A

2017 Rd.1 Australian GP

Ver.B

2017 Rd.6 Monaco GP

MFH
Model Factory Hiro

2-3-8 Higashihokima, Adachi-ku, Tokyo 121-0063
Phone: 81-3-5851-2522 Fax: 81-3-5851-2524

URL: <http://www.modelfactoryhiro.com/new/>
E-mail: cus@modelfactoryhiro.com

注意

* 組立て前に十分に仮組みを行って下さい。

- メタルパーツは変形している場合がありますが変形を調整しながら組立てを行って下さい。調整の際、多少の曲げは可能ですが破損にはご注意ください。
- レジンパーツの調整については、ドライヤー等で温めながら破損に注意しゆっくり行って下さい。
- 組立ての際、削り合わせ等が必要な部分もありますのでご注意ください。
- メタルパーツはバリやパーティングライン等を処理した後に、プライマーサフェーサー等で下地処理を行って下さい。
- レジンパーツは組立て、塗装前に離型剤クリーナー等で洗浄して下さい。
- 組立てには瞬間接着剤やエポキシ系ボンドをご使用下さい。
- デカールはファイル等に入れ、高温多湿を避けて保存して下さい。
- デカール保護紙がデカール面に密着しデカールニスに斑状の模様がつしまった場合は、デカールを貼った後にクリアを吹けば消えますので、そのように対処してください。
- 本製品は、中級者以上を対象とした組立てキットです。このキットには、尖った部品や小さな部品が含まれています。子供の誤飲や怪我、又ビニール袋による窒息などの事故にご注意ください。塗料、工具、接着剤等は、説明書に従い正しくお使い下さい。

CAUTION

* Please try temporarily constructing the kit before applying any adhesives.

- Metal parts may be slightly out of shape when first taken out of the box. You can restore the shape by carefully bending the part, but take caution as overexerting the part will cause it to snap.
- You can change the shape of the resin casting parts by applying heat (eg. using a dryer), but please be careful of damaging the part.
- Please be aware that some parts may have to be altered by cutting before they can fit together.
- After blur/parting lines have been removed from metal parts, please apply under coating (eg. primer surfacer) before continuing.
- Please clean resin parts (eg. using releasing agent) before applying color.
- Please use super glue or epoxy resin when building the kit.
- Protect decals by keeping them in dry and cool place inside a folder/file holder.
- If decal coating becomes damaged by the protective wax paper and forms a scaly pattern on the decal surface, apply a film of varnish after applying decal to restore coating.
- This kit is intended for ages 16 and over. Please keep out of reach from children as kit contains many small/sharp parts. Please read instructions carefully before applying colour/adhesives/altercation of parts etc.

PARTS LIST

TURNUED PARTS

<input type="checkbox"/>	T1	フロントホイールリム	Front wheel rim	2
<input type="checkbox"/>	T2	リアホイールリム	Rear wheel rim	2
<input type="checkbox"/>	T3	マフラーエンド	Muffler end	1

CLEAR PARTS

<input type="checkbox"/>	C1	テールランプ	Tail lamp	1
--------------------------	----	--------	-----------	---

OTHERS

<input type="checkbox"/>	黒ネジ	Black screw		
	φ1.4mm×3.0mm			
	φ2.0mm×6.0mm		12	
	φ2.0mm×10.0mm		2	
<input type="checkbox"/>	銀ネジ	Silver screw	5	
<input type="checkbox"/>	ピン	Pin	1	
<input type="checkbox"/>	洋白線	Nickel silver wire		
	φ0.4mm		1	
	φ0.8mm		1	

<input type="checkbox"/>	木目シール	Wood print sticker	1	
<input type="checkbox"/>	シートベルトセット	Seat belt set	1	
<input type="checkbox"/>	両面テープ	Adhesive tape	1	
<input type="checkbox"/>	フロントタイヤ	Front tire	2	
<input type="checkbox"/>	リヤタイヤ	Rear tire	2	
<input type="checkbox"/>	エッチング	Photo etched plate		
	φ0.15mm		1	
	φ0.3mm		1	
<input type="checkbox"/>	デカール	Decal	2	
<input type="checkbox"/>	マスキングデカール	Masking decal	2	

Color table

(注) この説明書ではグンゼ産業(GSIクレオス)のMr Colorを使用しています。
notice. The color, using on this instruction is Mr.color, from GUNZE SANGYO(GSI CREOS).

3	赤	Red
8	シルバー	Silver
9	ゴールド	Gold
33	ツヤ消し黒	Flat black
75	メタリックレッド	Metallic red
76	メタリックブルー	Metallic blue

92	半ツヤ黒	Semi gloss black
158	スーパーイタリアンレッド	Super Italian Red

マスキングデカール
Masking decal

C

詳しくは別紙を参照して下さい。
For details, please refer to the attached sheet

1

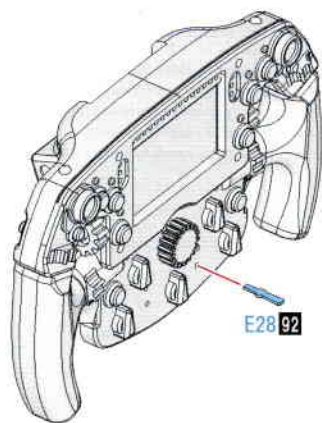
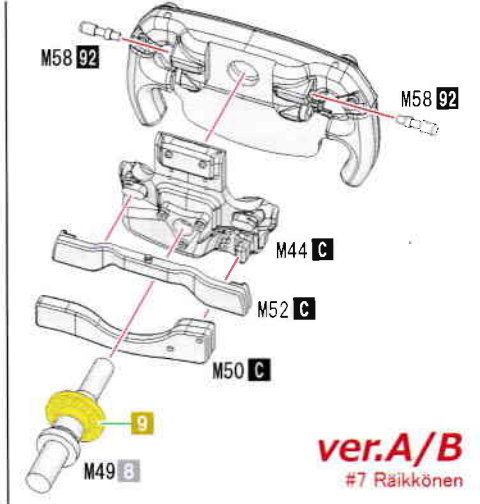
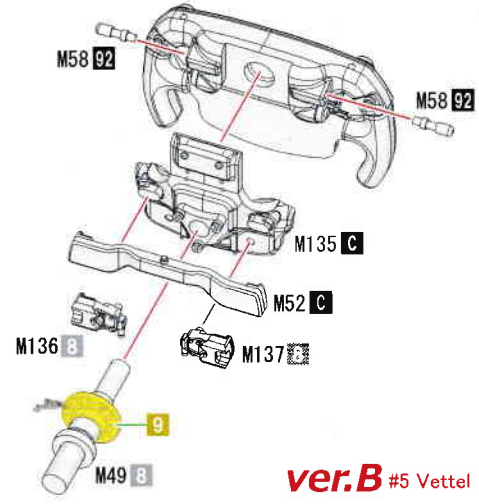
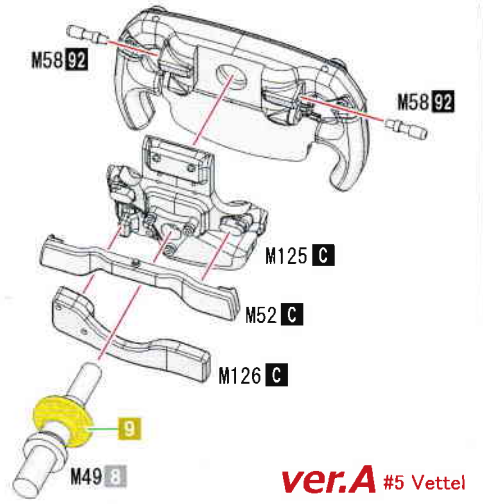
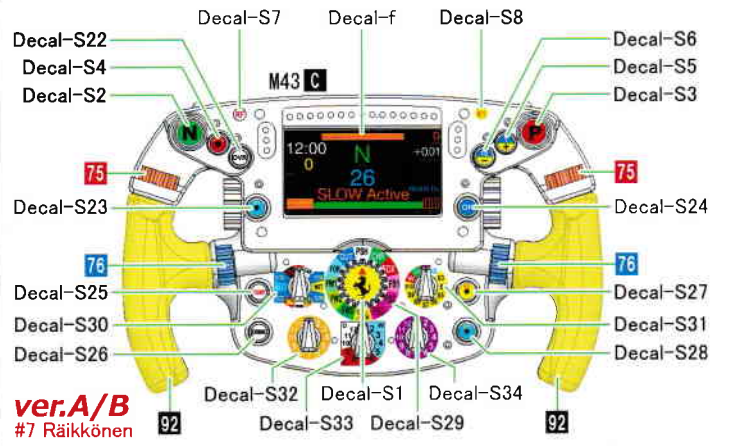
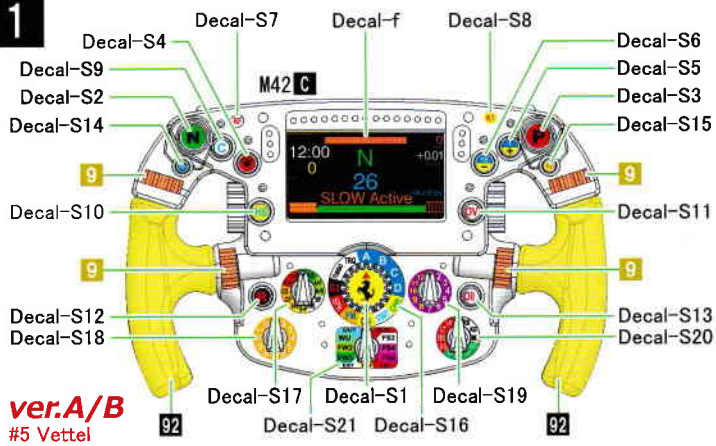

ver.A/B #5 Vettel

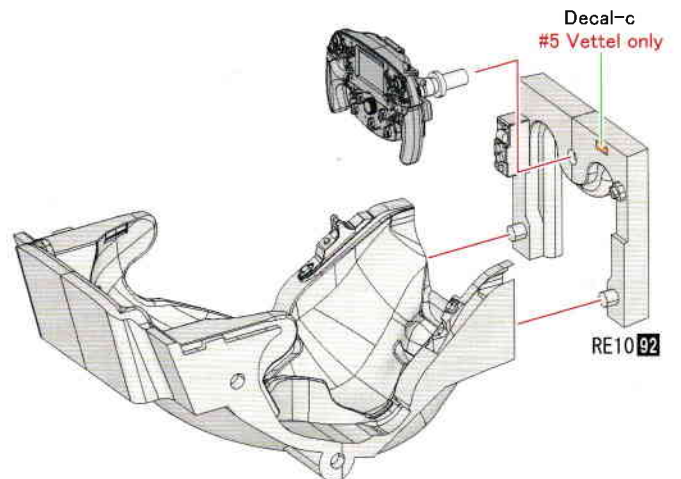
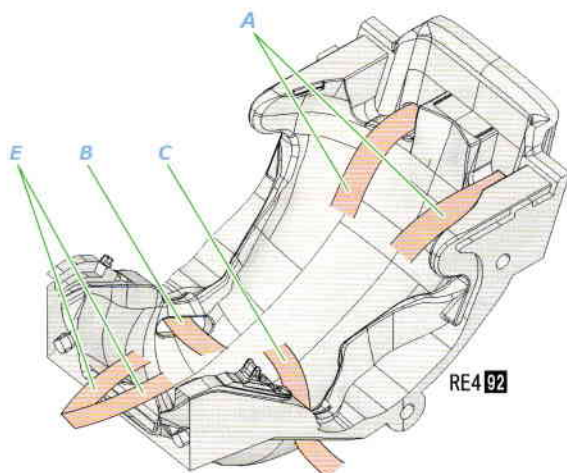
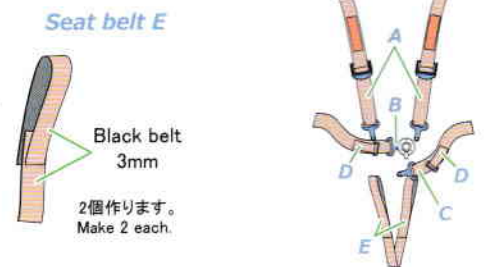
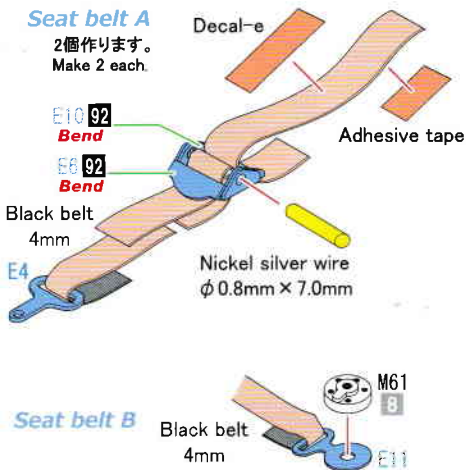

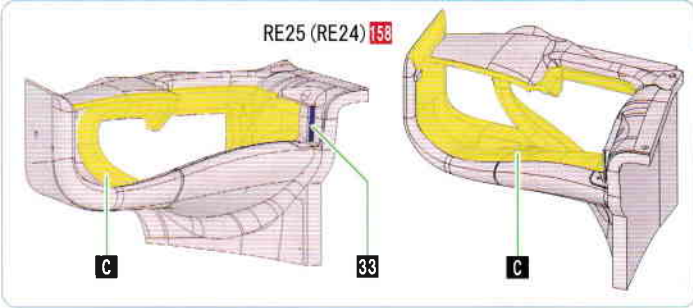

()内は反対側のパーツ番号です。
Numbers inside () are the opposite side parts number.

※ 取り付け後、境目をパテ等で消して下さい。
After attaching parts, please remove parting lines with putty etc.

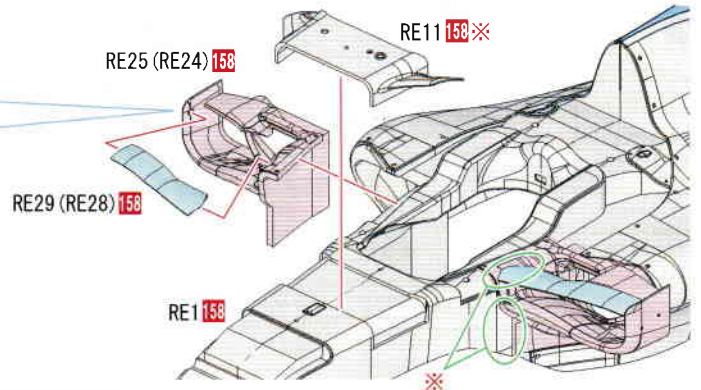

()内は反対側のパーツ番号です。
Numbers inside () are the opposite side parts number.

※ 取り付け後、境目をパテ等で消して下さい。
After attaching parts, please remove parting lines with putty etc.

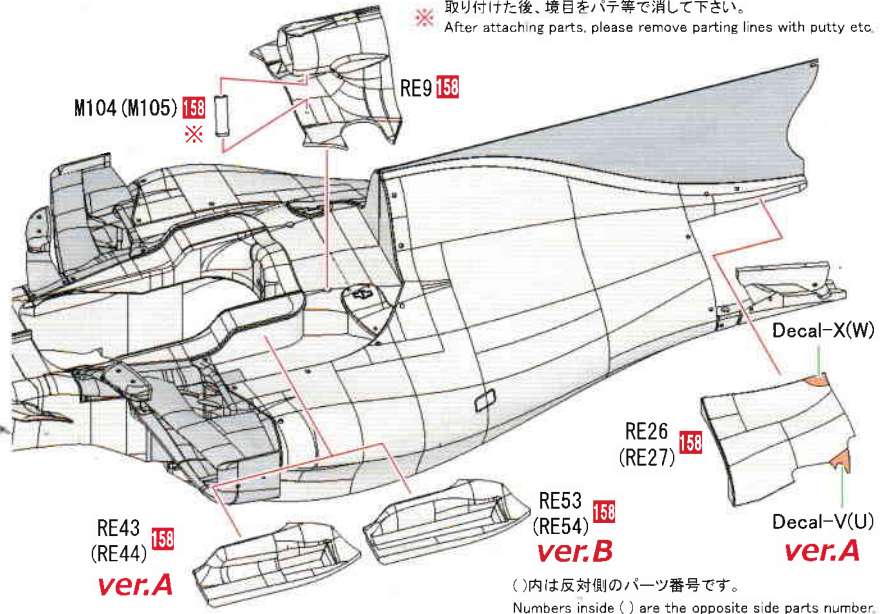
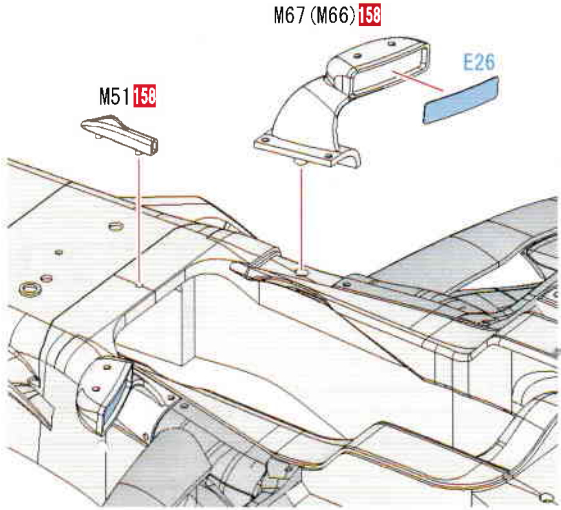

()内は反対側のパーツ番号です。
Numbers inside () are the opposite side parts number.

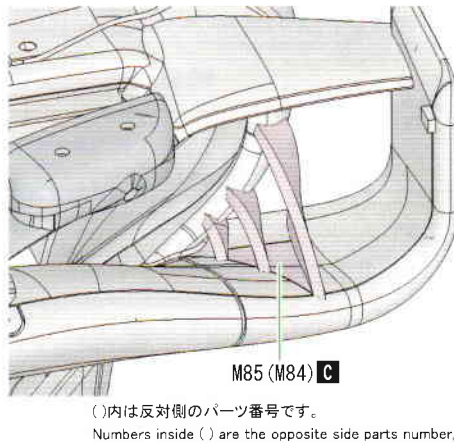
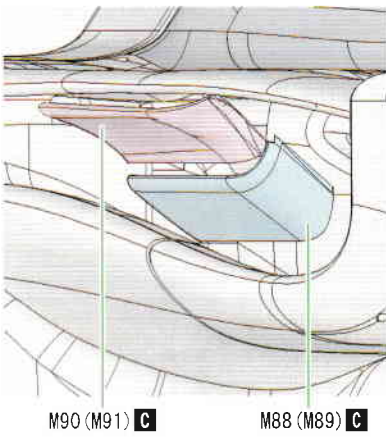

()内は反対側のパーツ番号です。
Numbers inside () are the opposite side parts number.

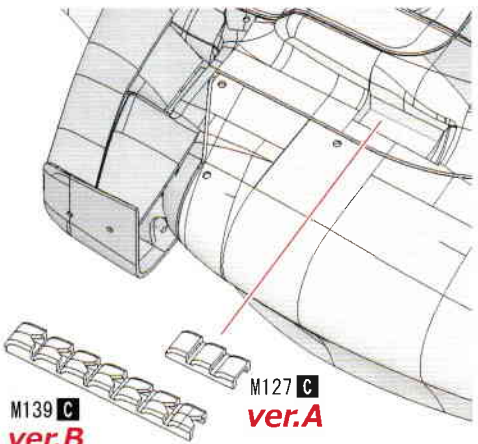
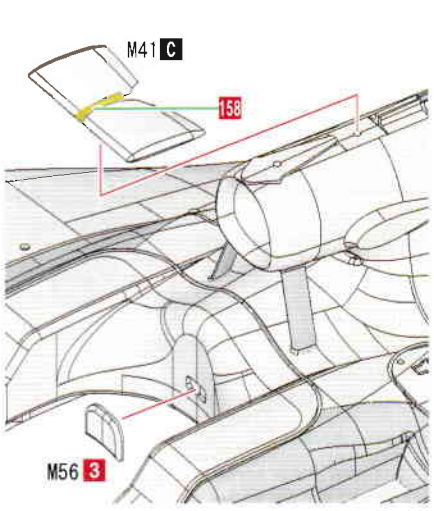
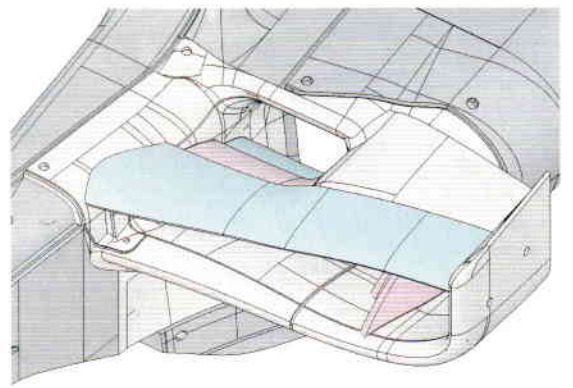

反対側も同様に取り付けます。
Please assemble the other side also as shown.

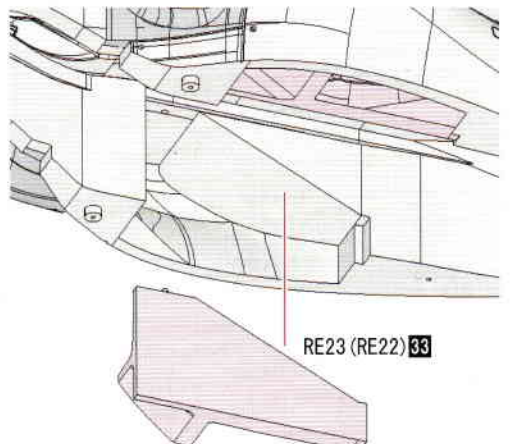

()内は反対側のパーツ番号です。
Numbers inside () are the opposite side parts number.

3

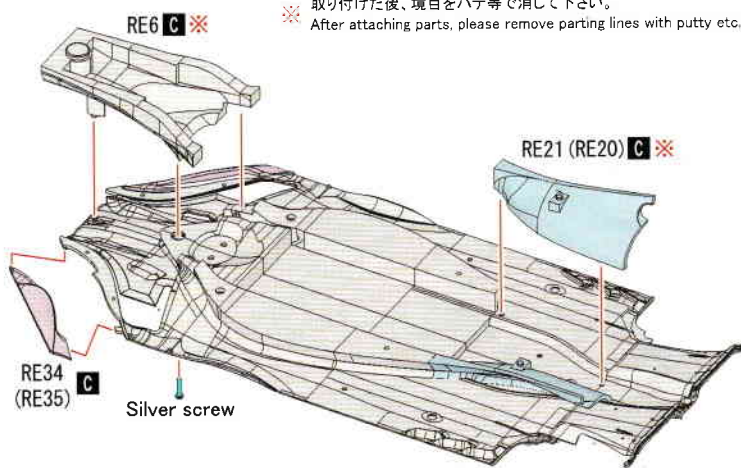
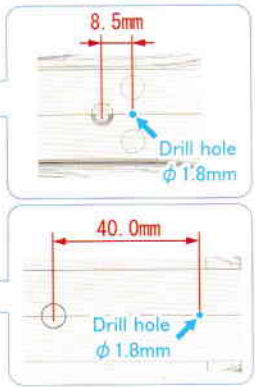
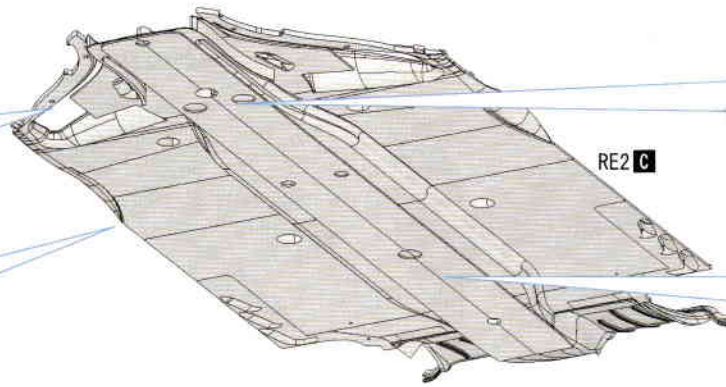
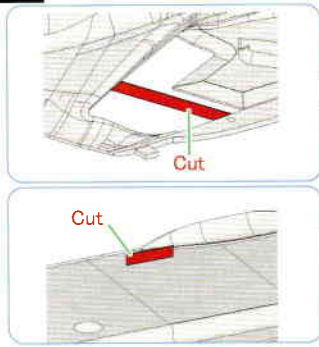

※ 取り付け後、境目をパテ等で消して下さい。
After attaching parts, please remove parting lines with putty etc.

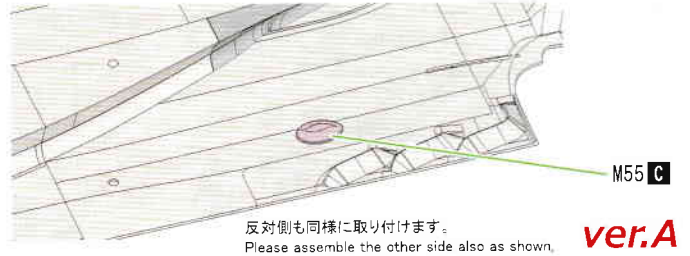

()内は反対側のパーツ番号です。
Numbers inside () are the opposite side parts number.

()内は反対側のパーツ番号です。
Numbers inside () are the opposite side parts number.

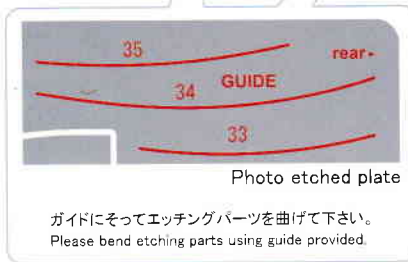
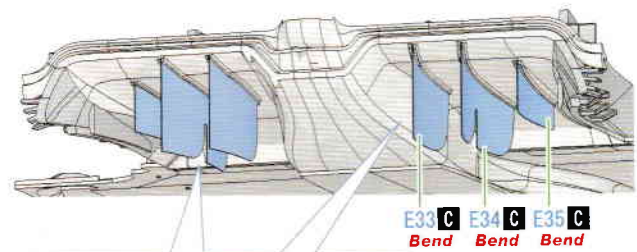
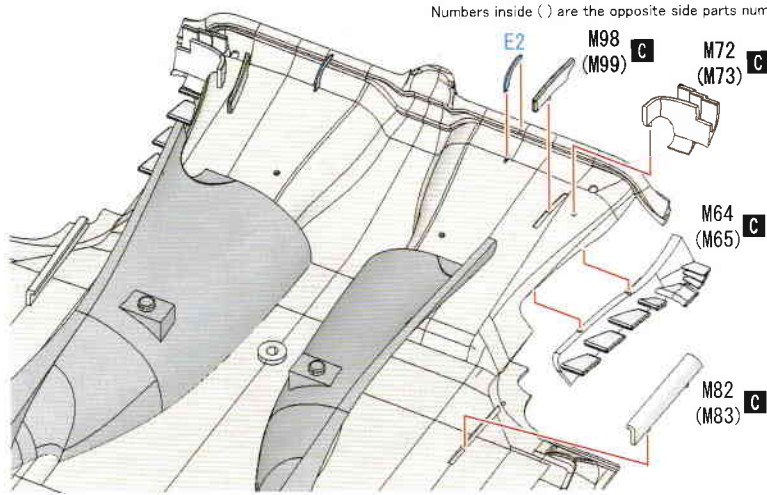

反対側も同様に取り付けます。
Please assemble the other side also as shown.

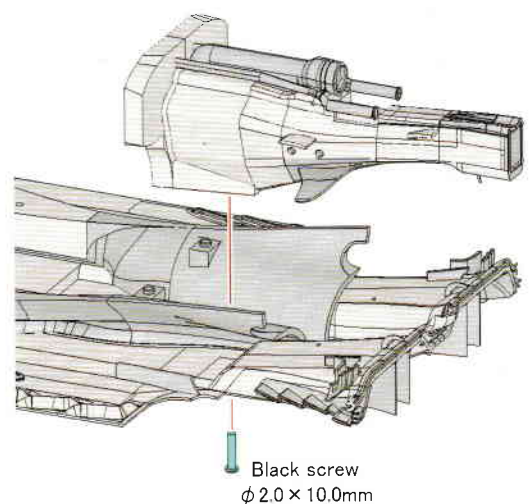
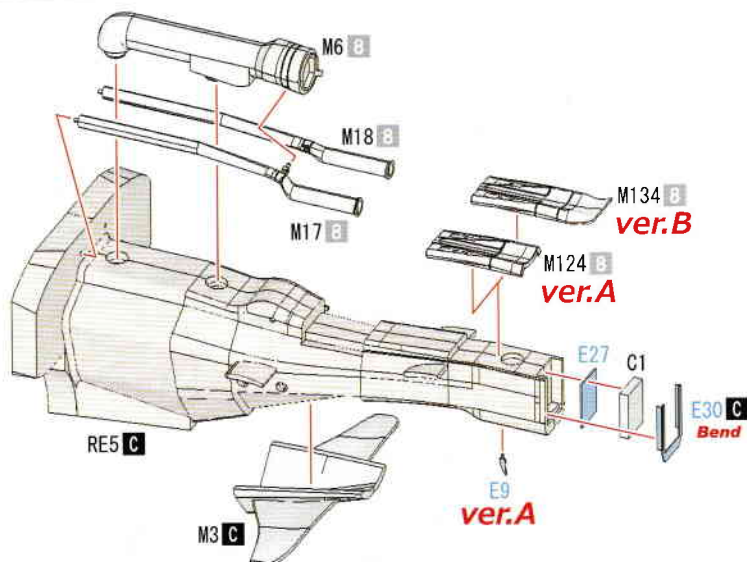

Black screw
φ 2.0 x 10.0mm

4

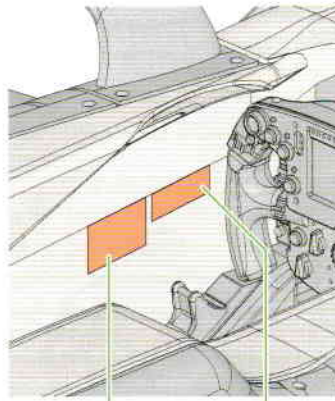
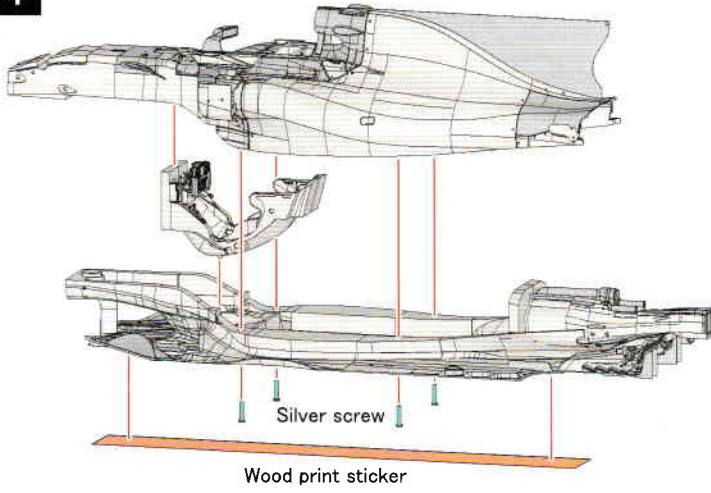

ver.A Decal-a
ver.B Decal-b

Decal-d

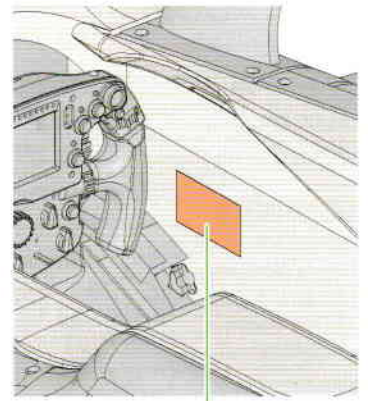

ver.A Decal-g
ver.B Decal-h

5

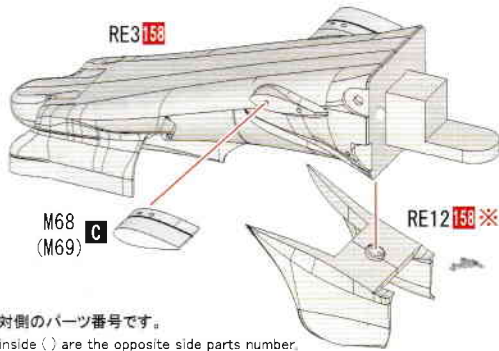

⟨ ⟩内は反対側のパーツ番号です。
Numbers inside ⟨ ⟩ are the opposite side parts number.

※ 取り付け後、境目をパテ等で消して下さい。
After attaching parts, please remove parting lines with putty etc.

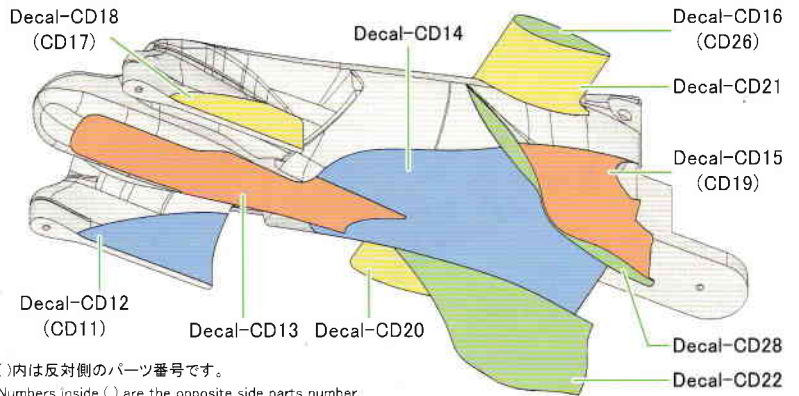

⟨ ⟩内は反対側のパーツ番号です。
Numbers inside ⟨ ⟩ are the opposite side parts number.

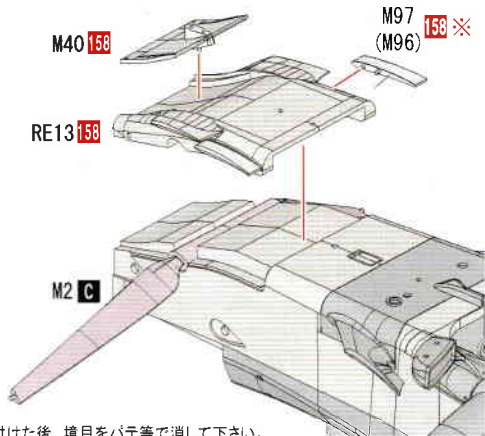

※ 取り付け後、境目をパテ等で消して下さい。
After attaching parts, please remove parting lines with putty etc.

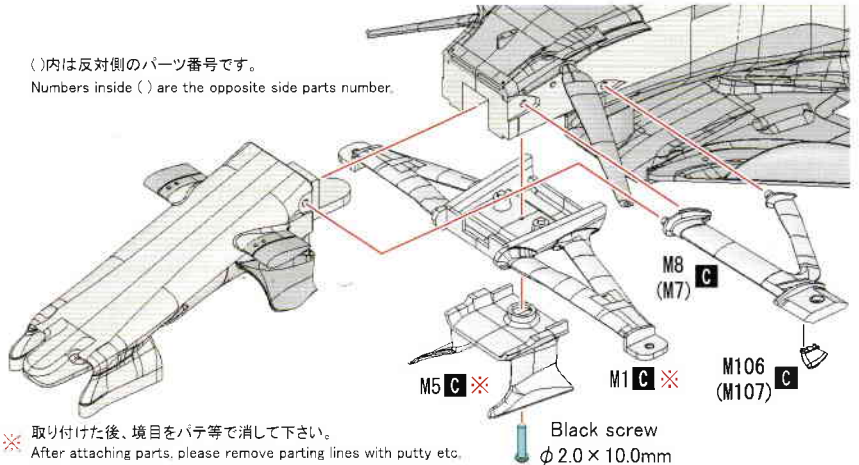

※ 取り付け後、境目をパテ等で消して下さい。
After attaching parts, please remove parting lines with putty etc.

Left side

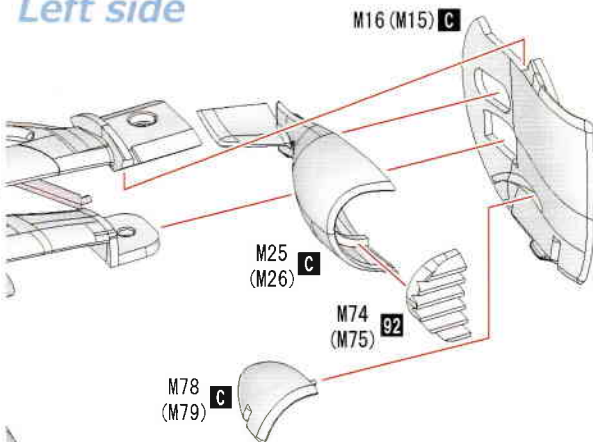

⟨ ⟩内は反対側のパーツ番号です。
Numbers inside ⟨ ⟩ are the opposite side parts number.

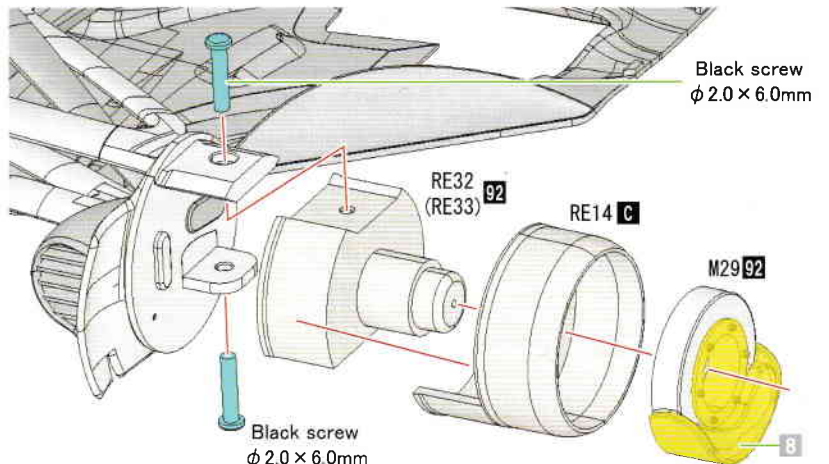

Left side

⟨ ⟩内は反対側のパーツ番号です。
Numbers inside ⟨ ⟩ are the opposite side parts number.

6

Right side

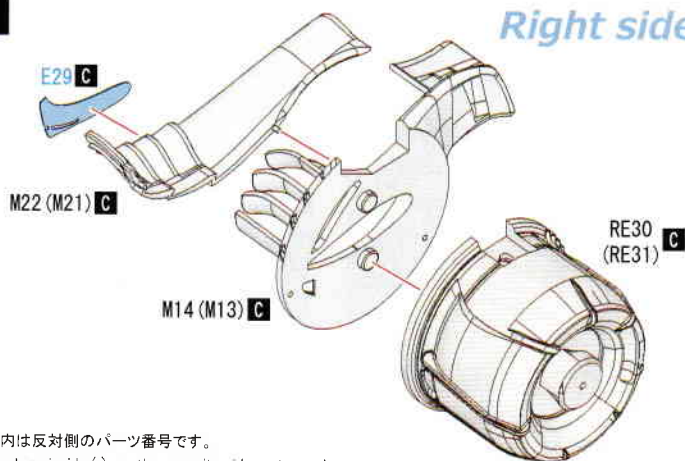

()内は反対側のパーツ番号です。
Numbers inside () are the opposite side parts number.

Right side

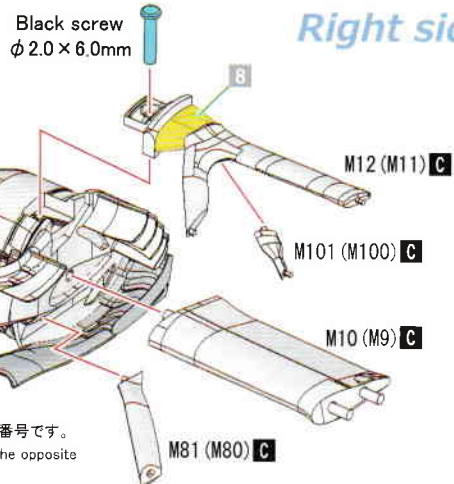

()内は反対側のパーツ番号です。
Numbers inside () are the opposite side parts number.

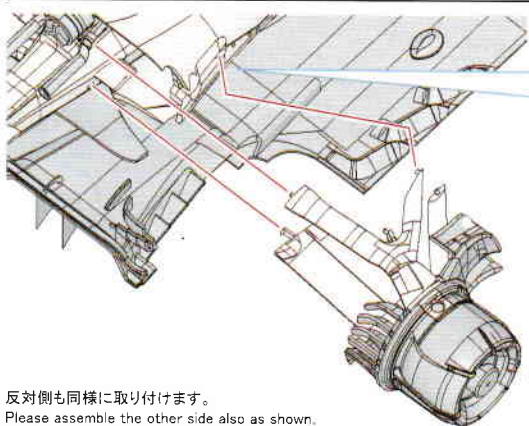

反対側も同様に取り付けます。
Please assemble the other side also as shown.

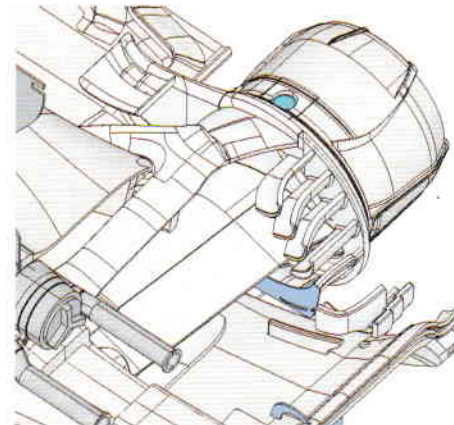
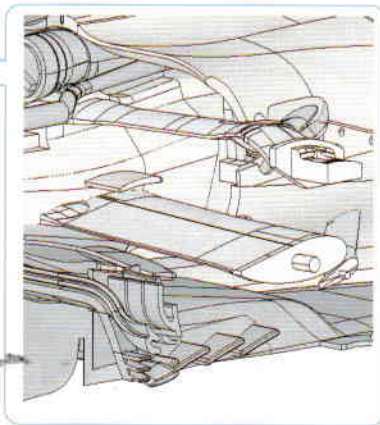

7

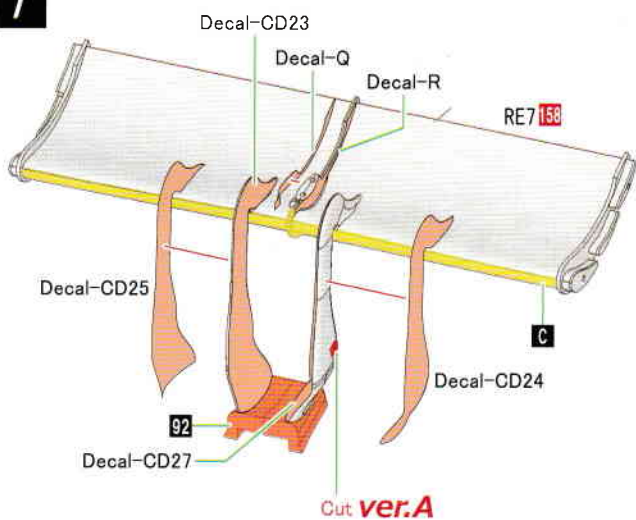

Cut ver.A

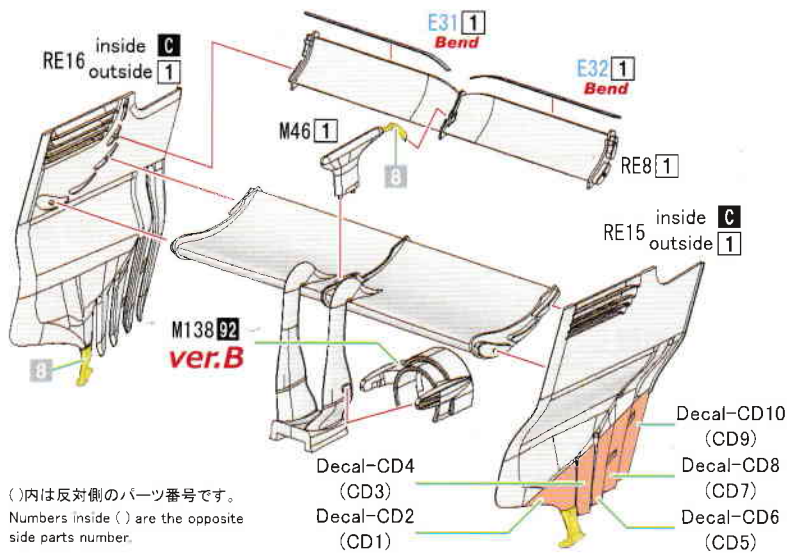

()内は反対側のパーツ番号です。
Numbers inside () are the opposite side parts number.

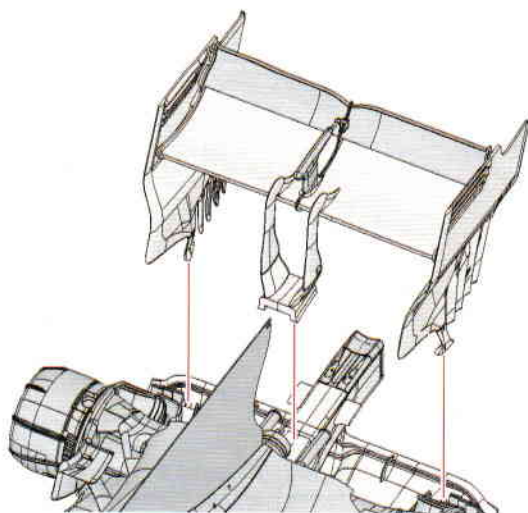

M123 (92 ver.A)

M133 (92 ver.B)

T3

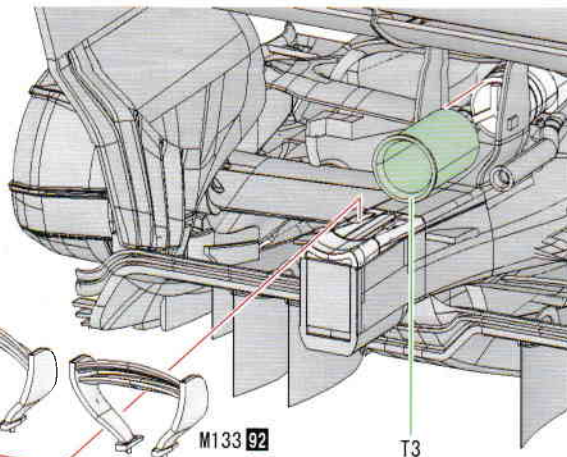

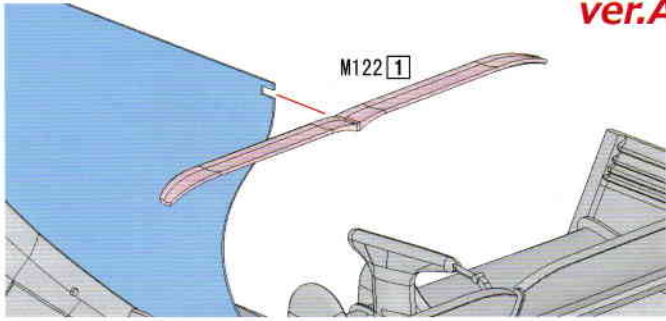
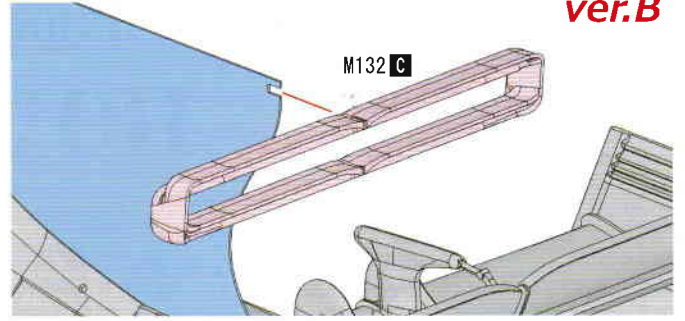
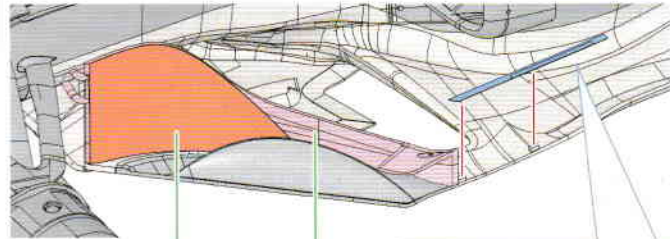
8**ver.A****ver.B****9****ver.A**

Decal-D(C) RE41 (RE42) (C)

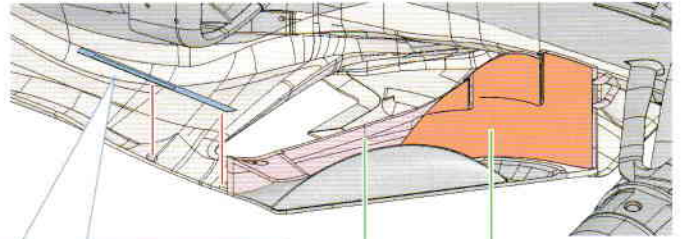
**ver.B**

RE52 (RE51) (C) Decal-A(B)

E20とE21をアンダーパネル(RE2)の形に沿うように曲げて下さい。
Please bend E20 and E21 to match shape of underpanel (RE2).

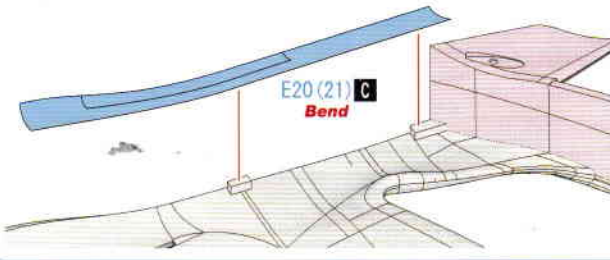

()内は反対側のパーツ番号です。
Numbers inside () are the opposite side parts number.

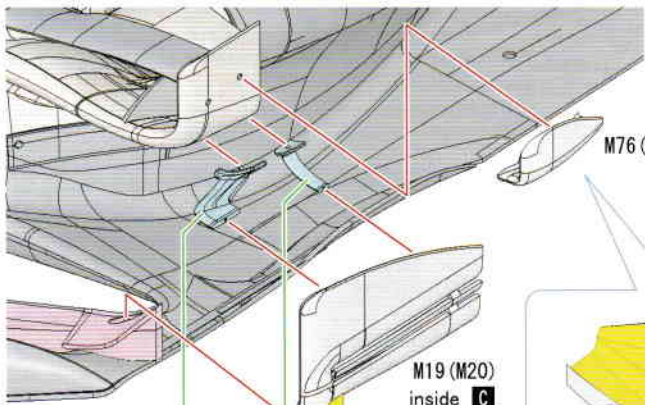

M92 (M93) (8) M102 (M103) (8) M19 (M20) inside (C) outside (158)

M76 (M77) (158)

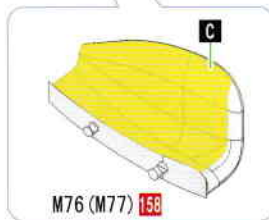

M76 (M77) (158)

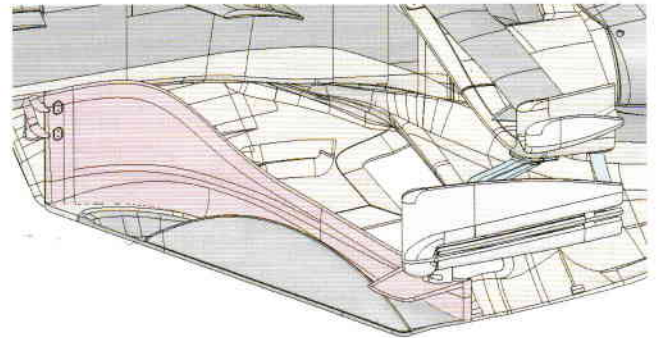

()内は反対側のパーツ番号です。
Numbers inside () are the opposite side parts number.

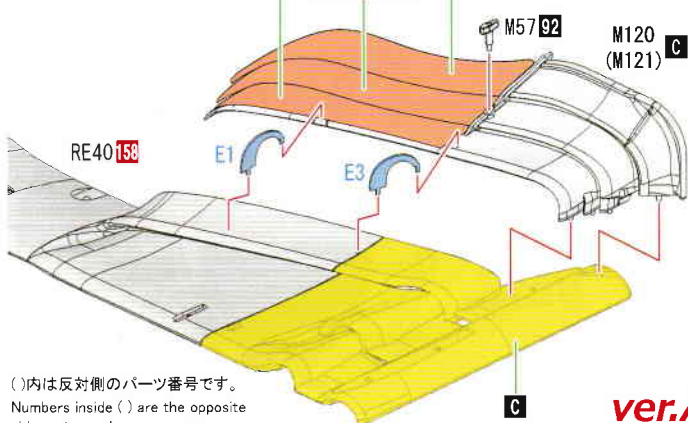
10Decal-L(K) Decal-P(O)
Decal-N(M)

()内は反対側のパーツ番号です。
Numbers inside () are the opposite side parts number.

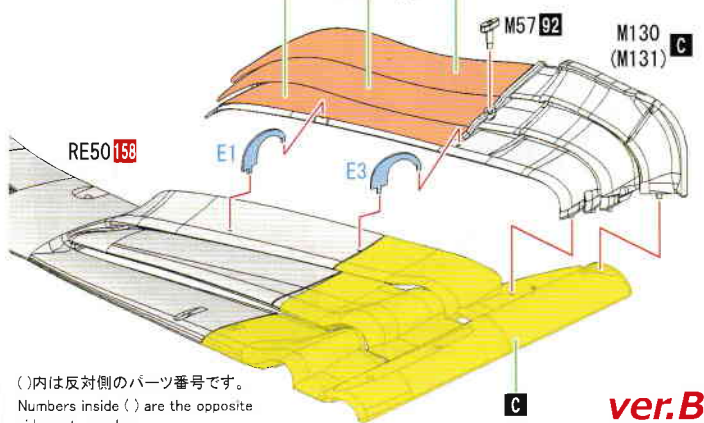
ver.ADecal-F(E) Decal-J(I)
Decal-H(G)

()内は反対側のパーツ番号です。
Numbers inside () are the opposite side parts number.

ver.B

11

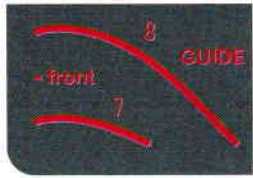
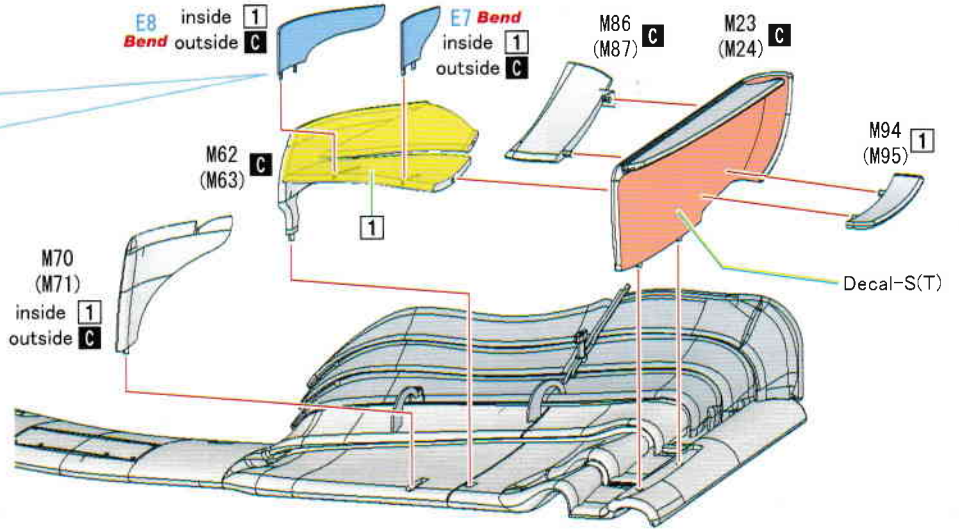
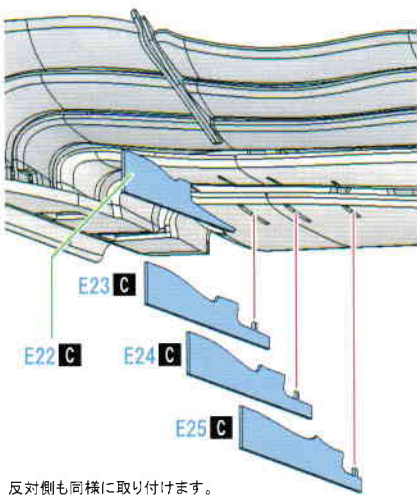

Photo etched plate

ガイドにそってエッチングパーツを曲げて下さい。
Please bend etching parts using guide provided.



()内は反対側のパーツ番号です。
Numbers inside () are the opposite side parts number.



反対側も同様に取り付けます。
Please assemble the other side also as shown.

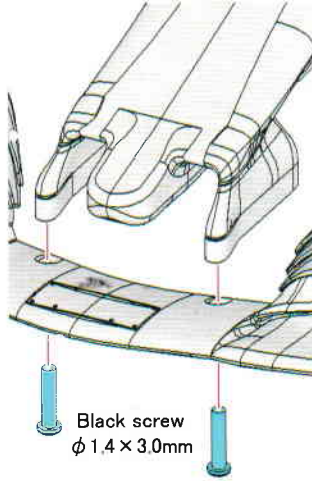

Black screw
φ 1.4 x 3.0mm

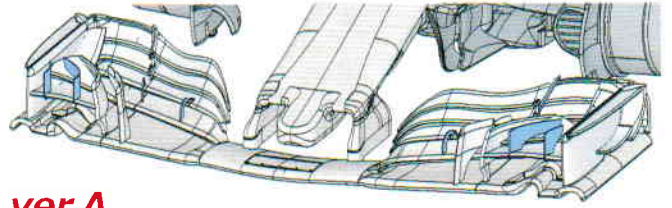

ver.A

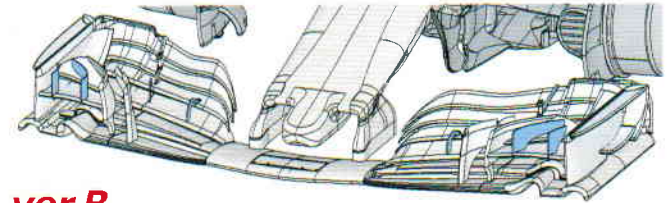

ver.B

12

Nickel silver wire
φ 0.4mm x 15.0mm

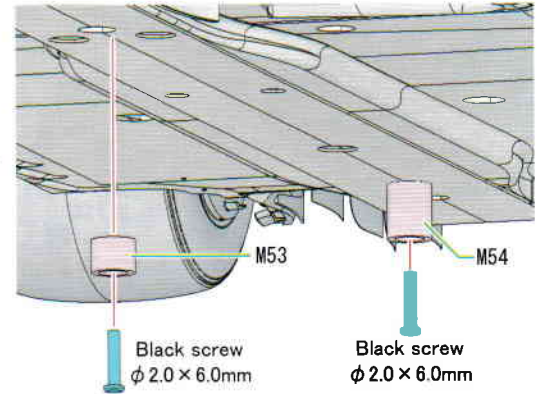
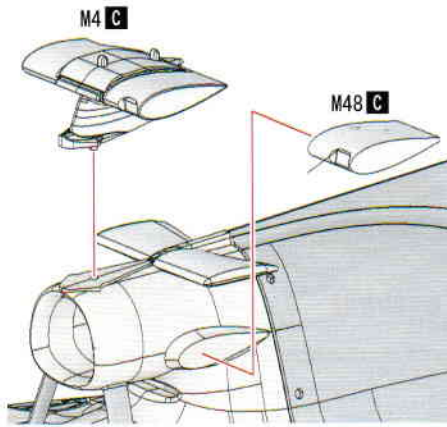
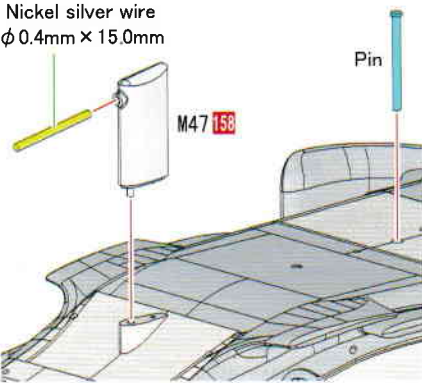

Black screw
φ 2.0 x 6.0mm

Black screw
φ 2.0 x 6.0mm

Spacer

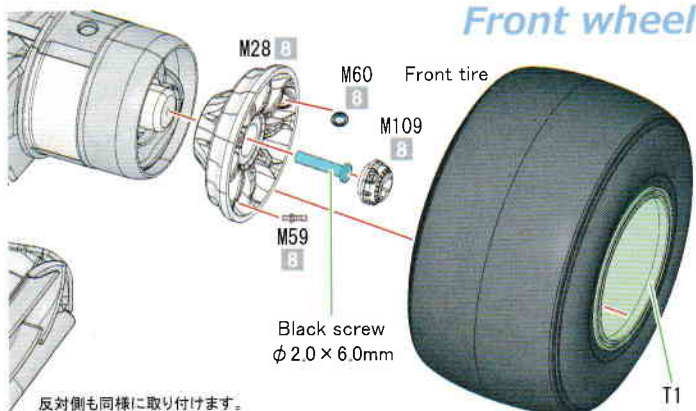

Front wheel

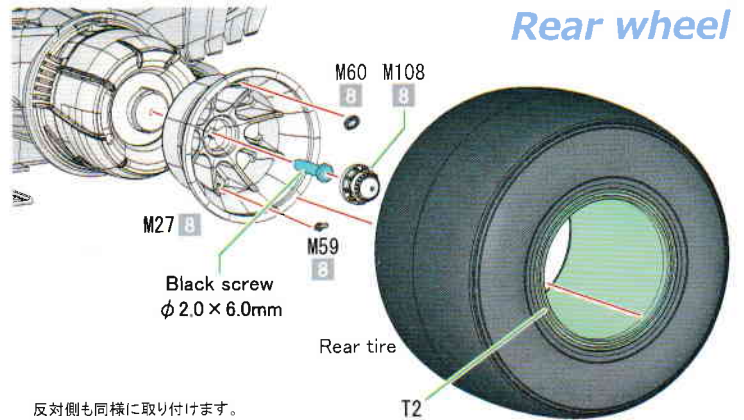

Rear wheel

反対側も同様に取り付けます。
Please assemble the other side also as shown.

反対側も同様に取り付けます。
Please assemble the other side also as shown.

DECAL GUIDE Ver.A Rd.1 Australian GP

○内は反対側のデカール番号です。

Numbers inside ○ are the opposite decal number.

[] Car No.7

※ デカールは必要に応じてカットして下さい。
Certain decals may need to be cut for proper display.

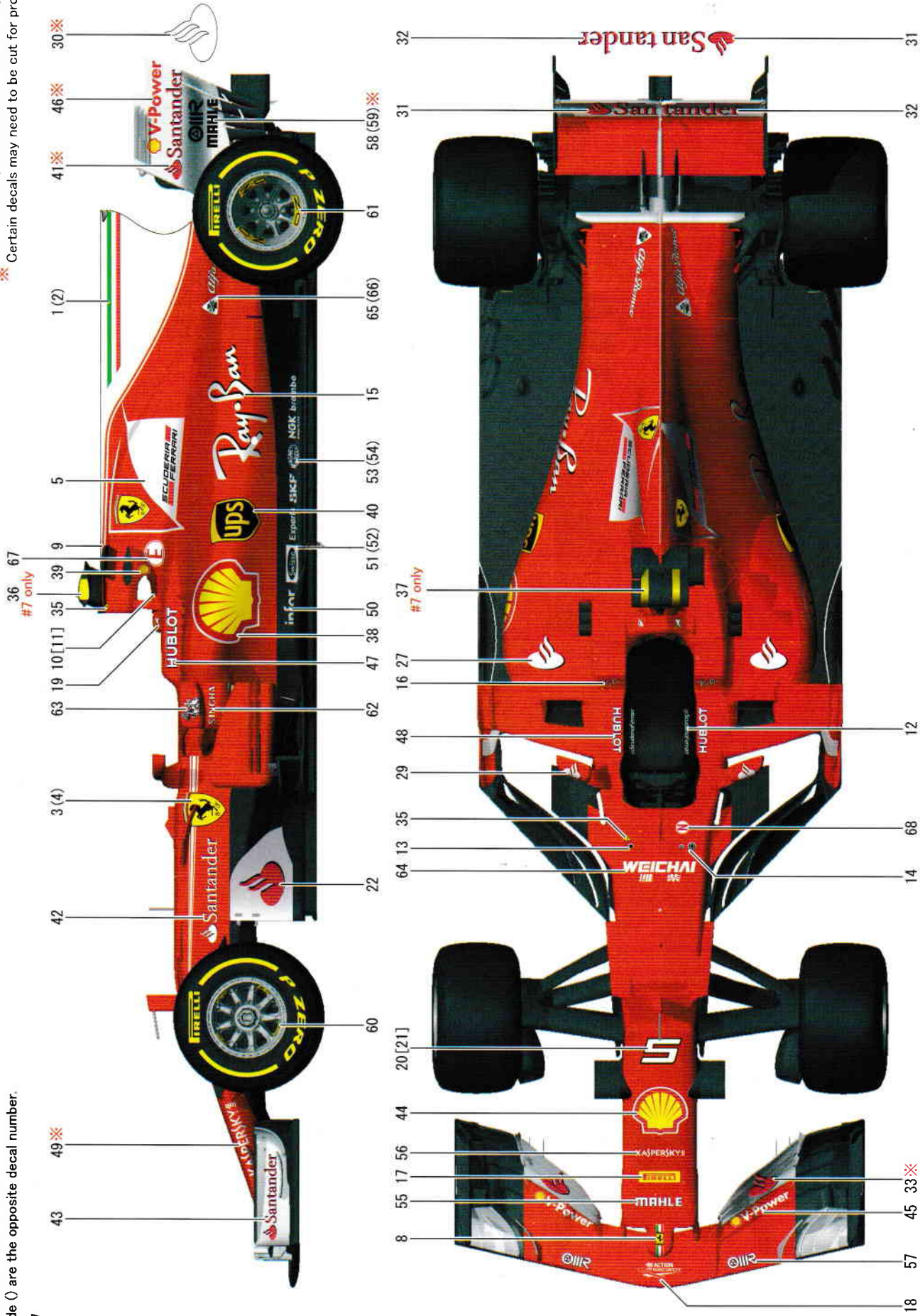

Ver.B Rd.6 Monaco GP

○内は反対側のデカール番号です。
Numbers inside ○ are the opposite decal number.

[] Car No.5

※ デカールは必要に応じてカットして下さい。
※ Certain decals may need to be cut for proper display.

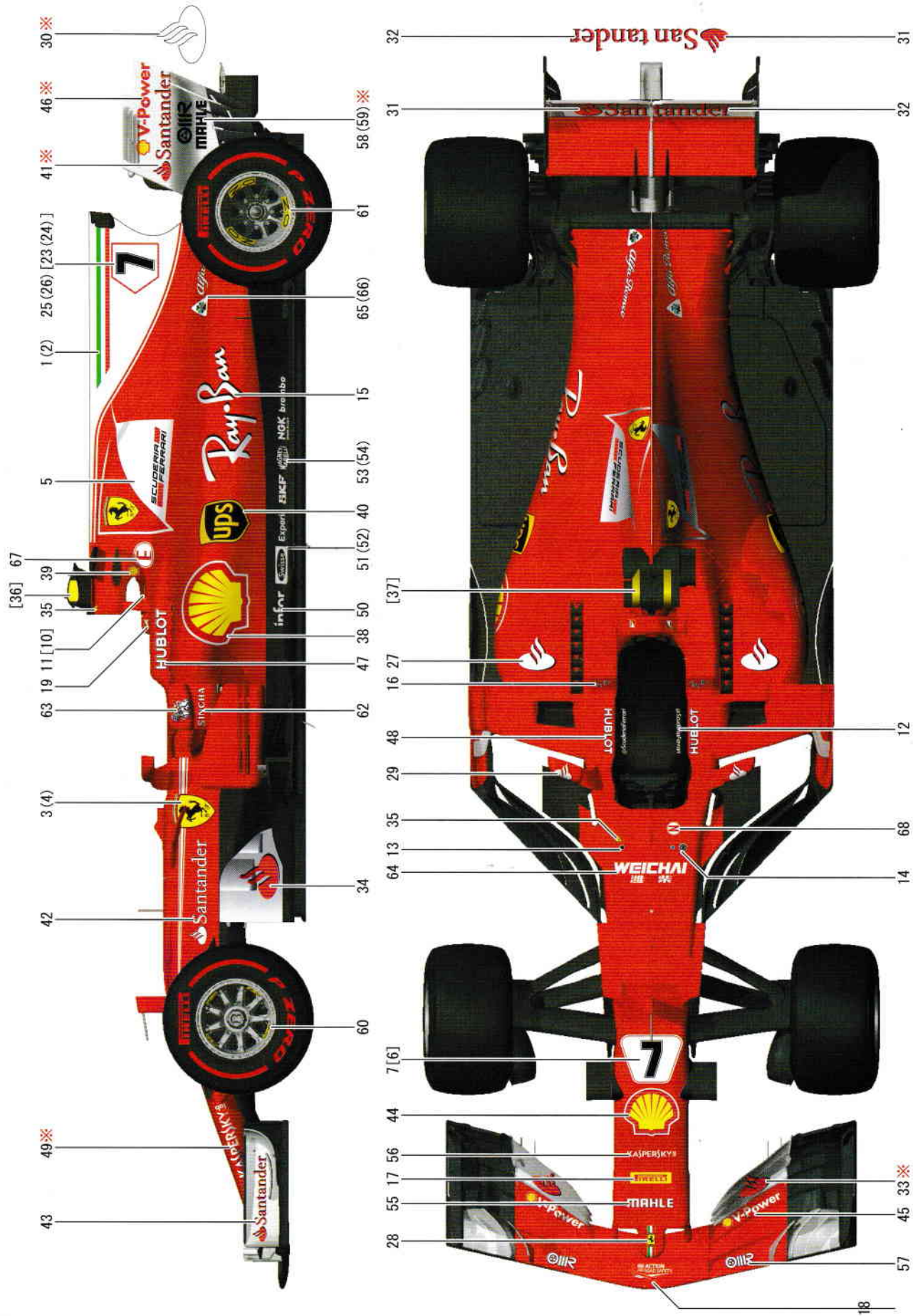

- 1 (2) 25 (26) [23 (24)] 30 ※
- 2 46 ※
- 3 (4) 41 ※
- 4 42
- 5 5
- 6 67
- 7 [6] 44
- 8 43
- 9 49 ※
- 10 [10] 35
- 11 63
- 12 12
- 13 64
- 14 14
- 15 15
- 16 27
- 17 56
- 18 18
- 19 19
- 20 29
- 21 48
- 22 16
- 23 47
- 24 38
- 25 50
- 26 51 (52)
- 27 40
- 28 55
- 29 57
- 30 30 ※
- 31 31
- 32 32
- 33 33 ※
- 34 34
- 35 35
- 36 [36] 67
- 37 [37]
- 38 47
- 39 39
- 40 40
- 41 41 ※
- 42 42
- 43 43
- 44 44
- 45 45
- 46 46 ※
- 47 47
- 48 48
- 49 49 ※
- 50 50
- 51 51 (52)
- 52 40
- 53 53 (54)
- 54 40
- 55 55
- 56 56
- 57 57
- 58 (59) ※
- 59 58 (59) ※
- 60 60
- 61 61
- 62 62
- 63 63
- 64 64
- 65 (66)
- 66 65 (66)
- 67 67
- 68 68