

1/20 Scale Multi-Material Kit

— K274 —

# Ferrari 312 F1

1967



**ROUND9/Italian GP**

#2 C.Amon



**ROUND10/US GP**

#9 C.Amon

## *INSTRUCTIONS*

**2-3-8 Higashihokima, Adachi-ku, Tokyo 121-0063**

**Phone: 81-3-5851-2522 Fax: 81-3-5851-2524**

**URL: <http://www.modelfactoryhiro.com>**

**E-mail: [cus@modelfactoryhiro.com](mailto:cus@modelfactoryhiro.com)**

**MFH**  
Model Factory Hiro

# Parts List

## TURNED PARTS

<input type="checkbox"/>	T1	エキゾーストエンド A	Exhaust end A	2
<input type="checkbox"/>	T2	エキゾーストエンド B	Exhaust end B	2
<input type="checkbox"/>	T3	フロントホイール	Front wheel	2
<input type="checkbox"/>	T4	リアホイール	Rear wheel	2
<input type="checkbox"/>	T5	ダンパー A	Damper A	4
<input type="checkbox"/>	T6	ダンパー B	Damper B	4
<input type="checkbox"/>	T7	ファンネル	Funnel	1 2

## VACUUM PARTS

<input type="checkbox"/>	V1	ウインドシールド A	Wind shield A	1
--------------------------	----	------------	---------------	---

## CLEAR PARTS

<input type="checkbox"/>	C1	バッテリー A	Battery A	1
<input type="checkbox"/>	C2	バッテリー B	Battery B	1
<input type="checkbox"/>	C3	リザーバータンク	Reservoir tank	1
<input type="checkbox"/>	C4	キャッチタンク	Catch tank	1

## OTHERS

<input type="checkbox"/>		ファンネルメッシュ	Funnel mesh	1 2
--------------------------	--	-----------	-------------	-----

## OTHERS

<input type="checkbox"/>	洋白線	Nickel silver wire	
	φ1.0mm		1
	φ0.8mm		1
	φ0.5mm		1
<input type="checkbox"/>	ステンレスパイプ	Stainless pipe	
	φ1.5mm		1
	φ1.0mm		1
<input type="checkbox"/>	黒ネジ (大)	Black screw(L)	8
<input type="checkbox"/>	黒ネジ (小)	black screw(S)	2
<input type="checkbox"/>	ネジ	Screw	4
<input type="checkbox"/>	ナット	Nut	4
<input type="checkbox"/>	ダンパースプリング	Damper spring	4
<input type="checkbox"/>	マフラスプリング	Muffler spring	4
<input type="checkbox"/>	平リベット	Flat rivet	1 8
<input type="checkbox"/>	プラグコード φ0.8mm	Plug cord	1
<input type="checkbox"/>	パイピングコード φ0.4mm	Piping cord	1
<input type="checkbox"/>	クリアチューブ	Clear tube	1
<input type="checkbox"/>	カラーチューブ	Color tube	1
<input type="checkbox"/>	熱収縮チューブ	Heat shrinkage tube	1
<input type="checkbox"/>	フロントタイヤ	Front tire	2
<input type="checkbox"/>	リアタイヤ	Rear tire	2
<input type="checkbox"/>	シートベルト	Seat belt	1
<input type="checkbox"/>	レザーシート	Leather sheet	1
<input type="checkbox"/>	デカール	Decal	1
<input type="checkbox"/>	エッチング	Photo etched plate	2

デカールはファイル等に入れて別途に保存して下さい。  
 デカールに白い粉末が付いている物がありますが、品質には問題ありません。  
 Preserve decals in other files for keep their condition.  
 Even if white powder is attached to decals, there is no problem.

### 注意

本製品は、中級者以上を対象とした組立てキットです。  
 このキットには、尖った部品や小さな部品が含まれています。  
 子供の誤飲や怪我、又ビニール袋による窒息などの事故にご注意ください。  
 塗料、工具、接着剤等は、説明書に従い正しくお使い下さい。

### CAUTION

This kit is intended for over 16 years old.  
 Small parts and sharp parts are included,so keep away from reach of children.  
 Read carefully each instruction before use tools,cutter,adhesive,etc.

## Color table

notice. The color, using on this instruction is Mr.color, from GUNZE SANGYO(GSI CREOS).

(注) この説明書ではグンゼ産業(GSIクレオス)の Mr Colorを使用しています。

<b>0</b>	磨き出し	Polish	<b>28</b>	黒鉄色	Steel
<b>3</b>	赤	Red	<b>30</b>	フラットベース	Flat base
<b>7</b>	ブラウン	Brown	<b>62</b>	ツヤ消し白	Flat white
<b>8</b>	シルバー	Silver	<b>92</b>	半ツヤ黒	Semi gloss black
<b>9</b>	ゴールド	Gold	<b>133</b>	スーパーイタリアレッド	Super italian red

**組み立て前に十分に仮組みを行って下さい。 Do carefully a temporary assembling.**

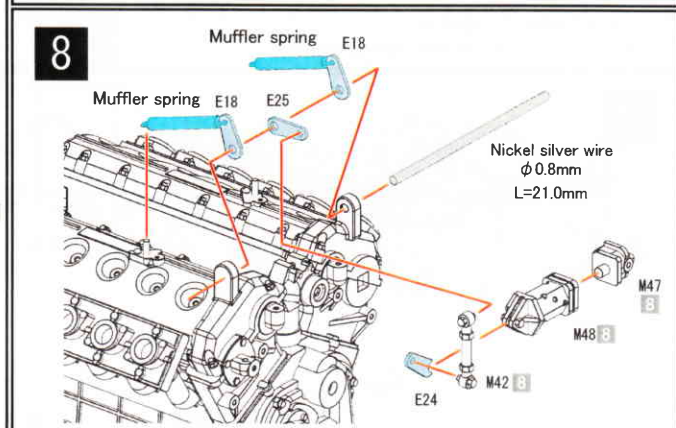
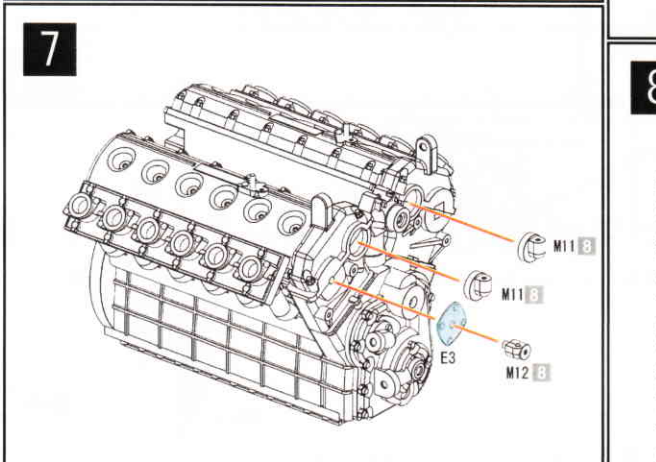
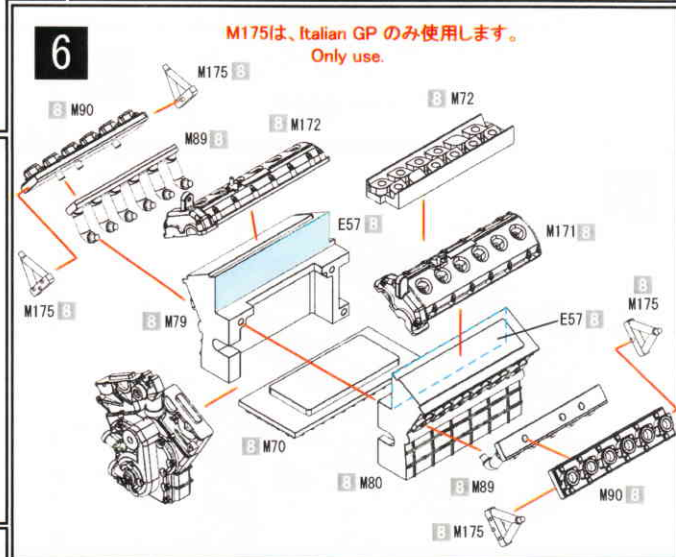
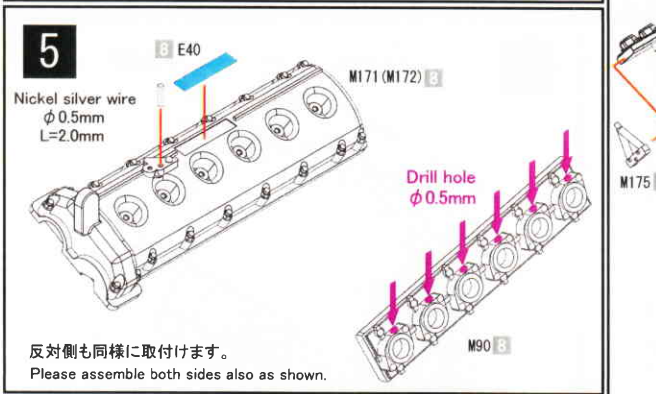
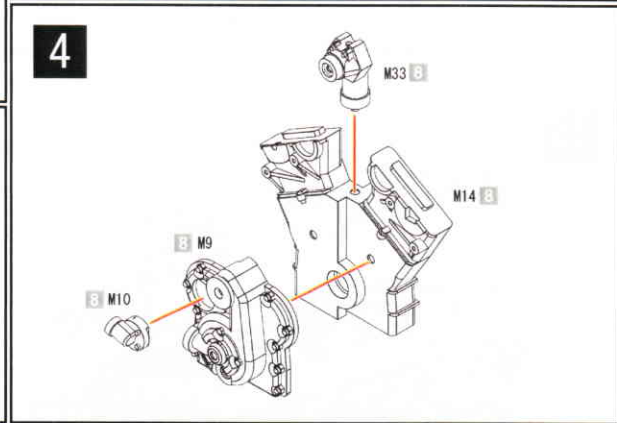
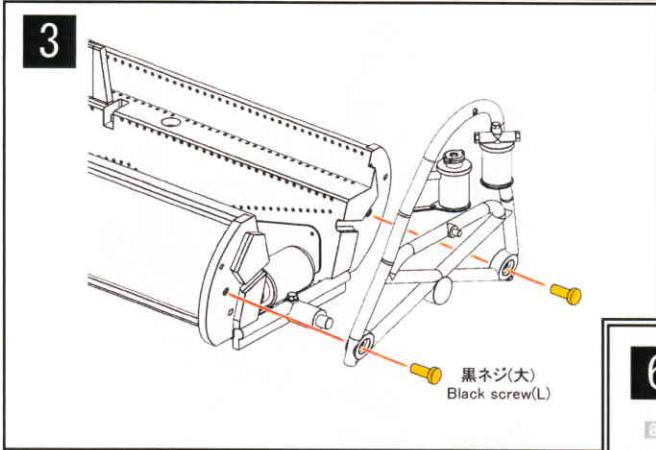
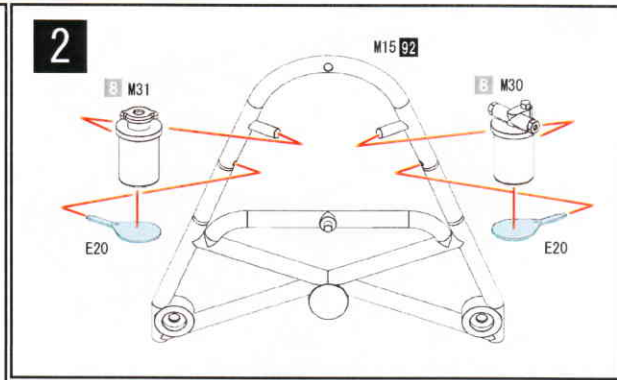
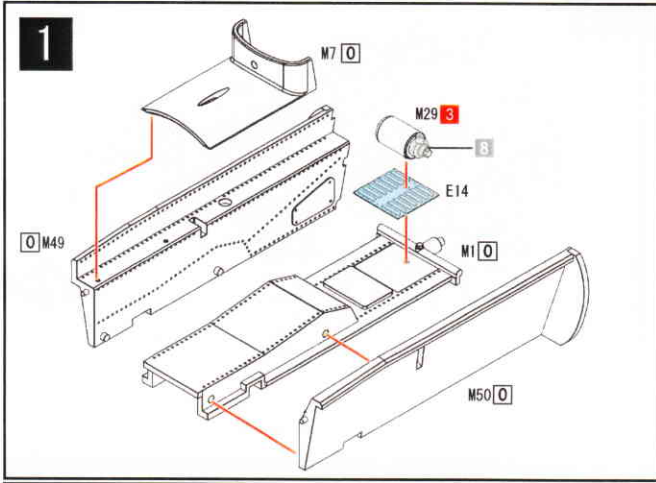

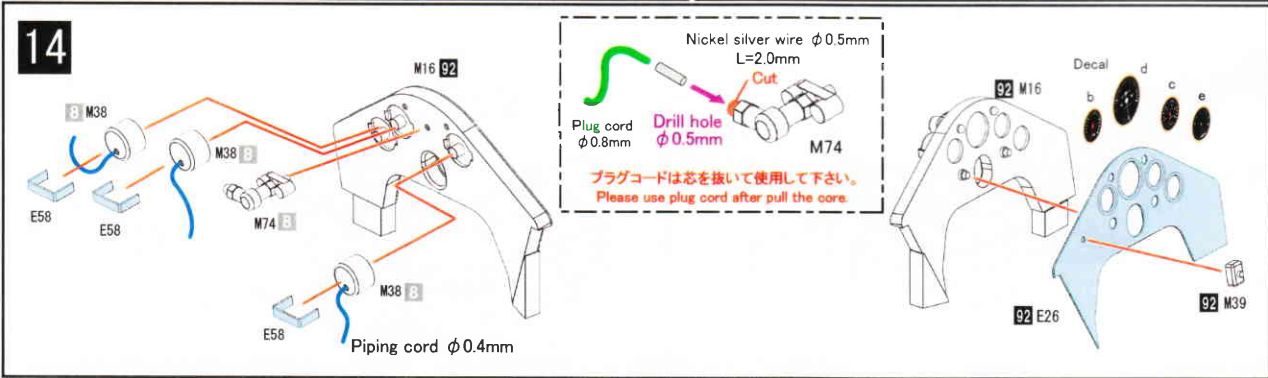
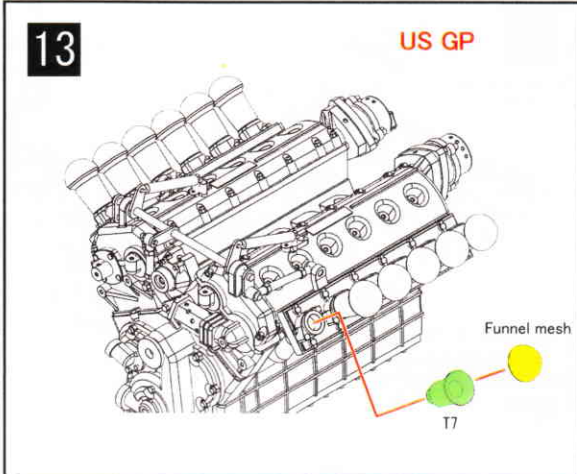
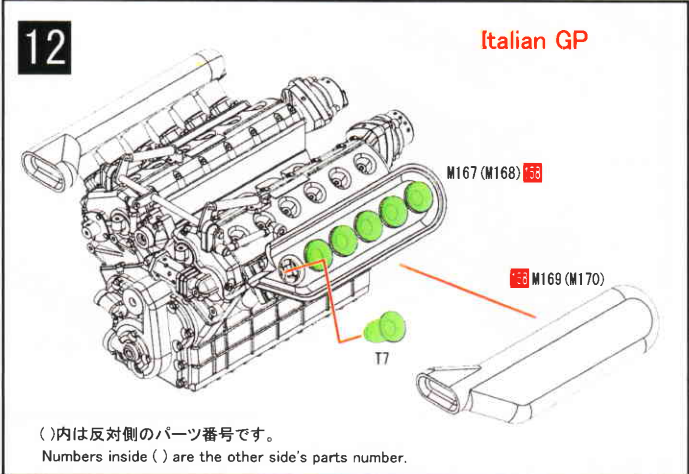
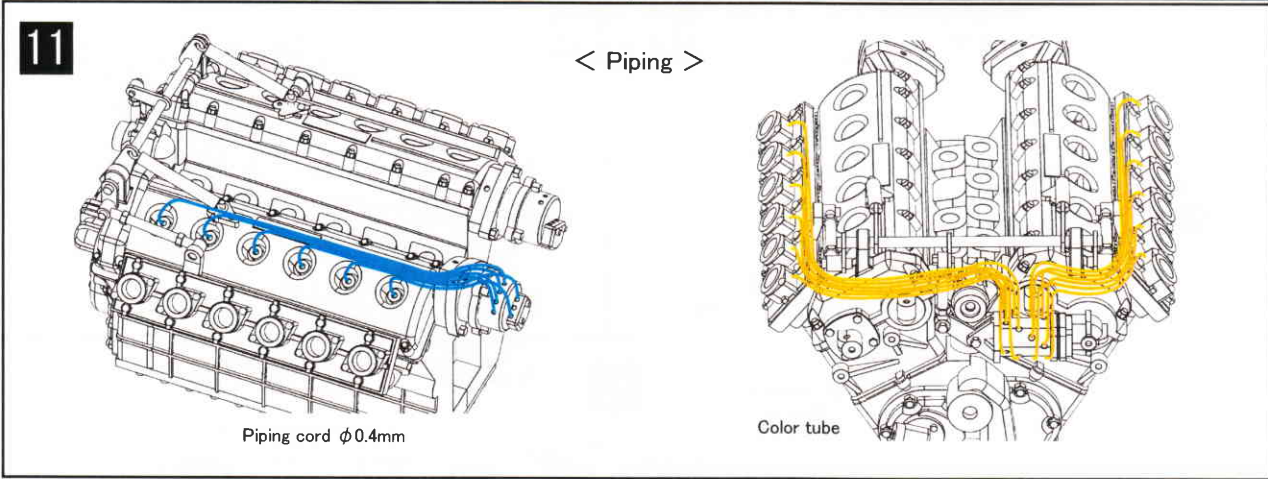
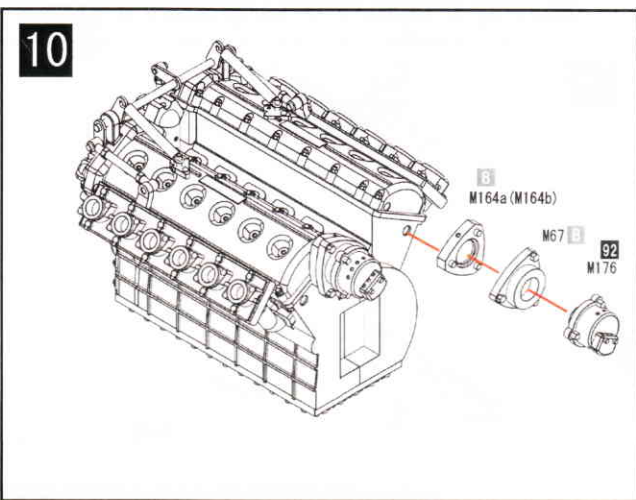
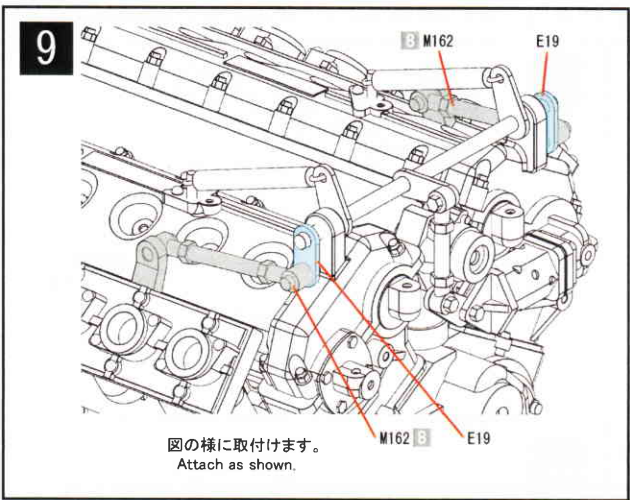

15

黒ネジ(大)  
Black screw(L)

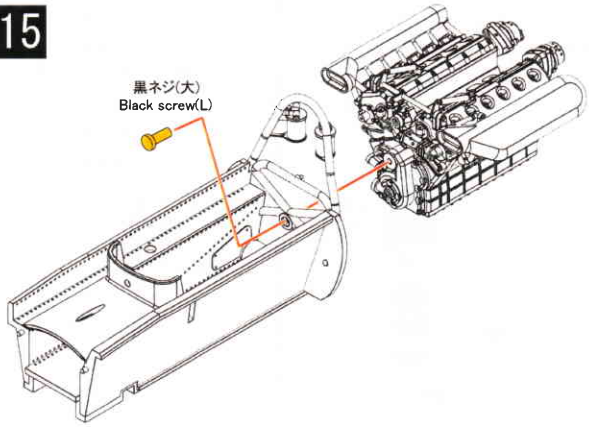

16

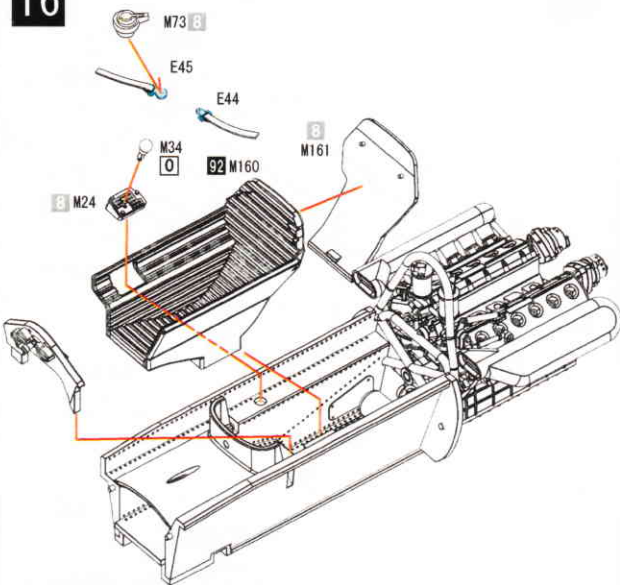

17

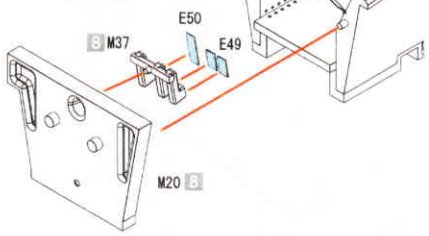

19

< Piping >

- Piping cord  $\phi$ 0.4mm
- Plug cord  $\phi$ 0.8mm

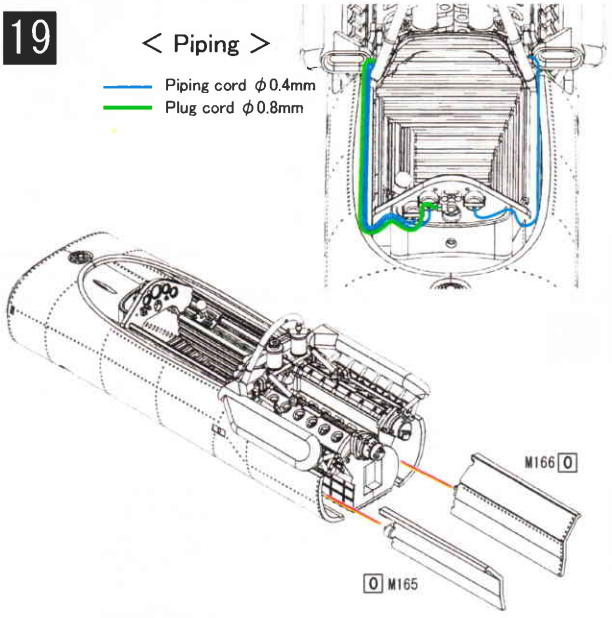

18

黒ネジ(大)  
Black screw(L)

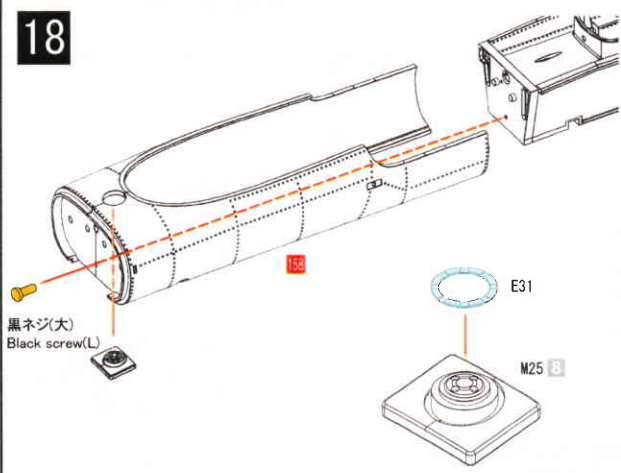

21

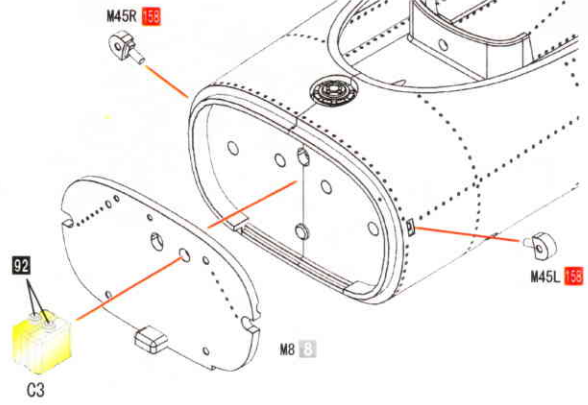

20

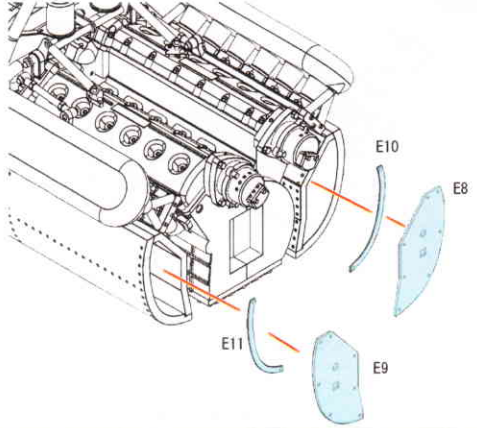

22

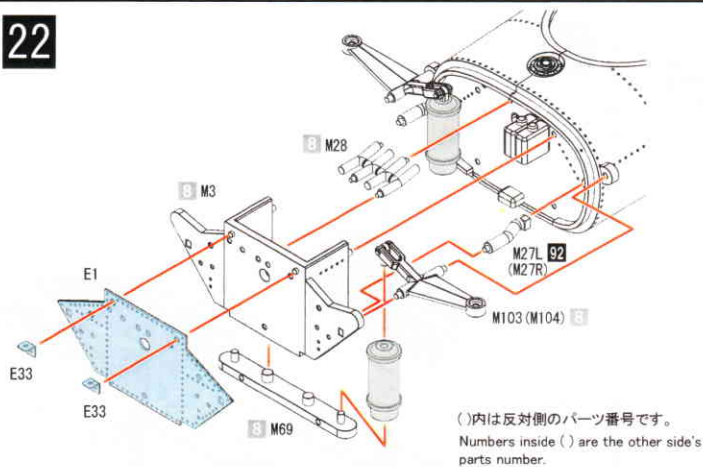

Damper



4個作ります。  
Make 4 each.

折り曲げガイド  
<Actual size>  
Nickel silver wire  $\phi$ 0.8mm  
L=44.0mm

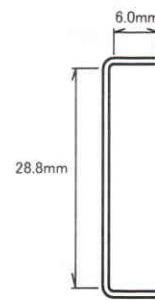

23

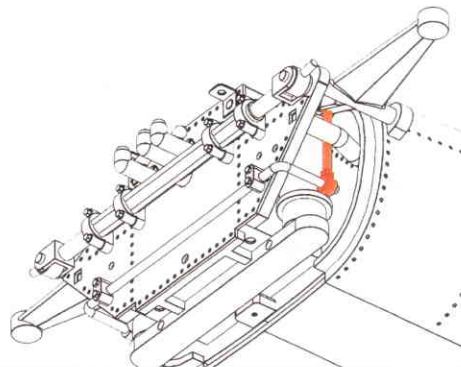
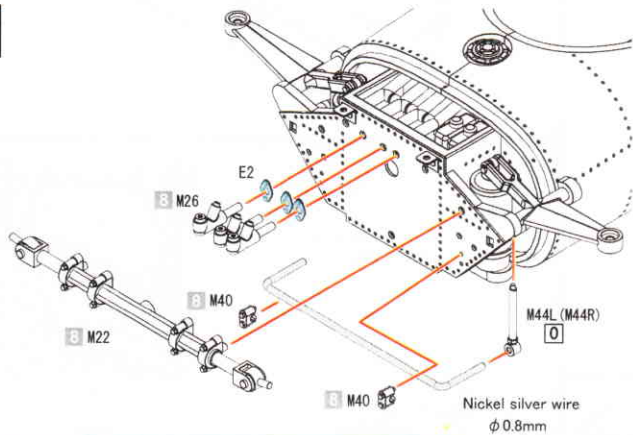

図の様に取付けます。  
Attach as shown.

24

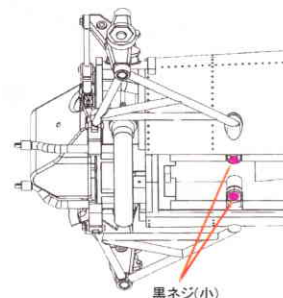
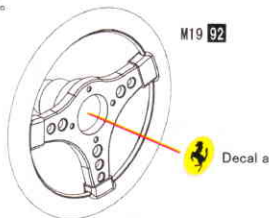
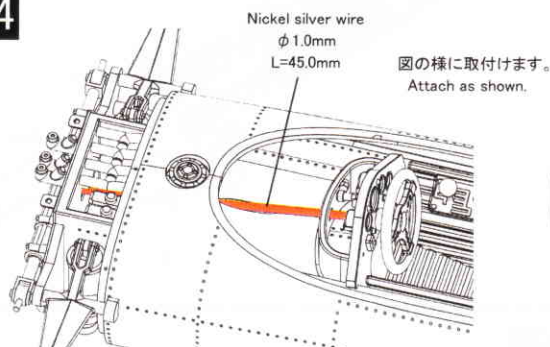

黒ネジ(小)  
Black screw(S)

25

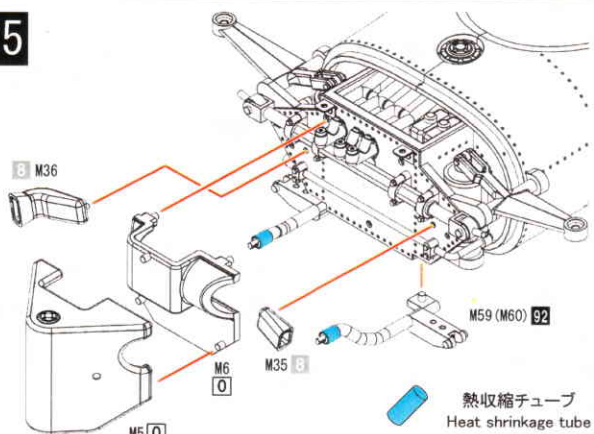

取付けた後に熱を加えて下さい。  
Please add heat after attached.

26

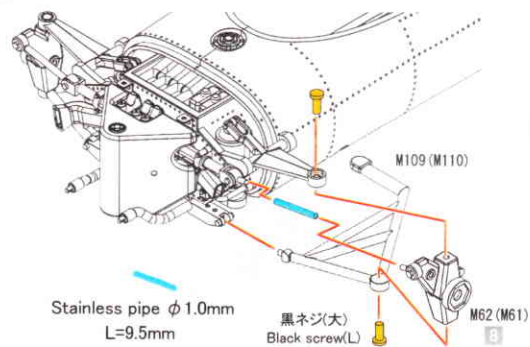

( )内は反対側のパーツ番号です。  
Numbers inside ( ) are the other side's parts number.

27

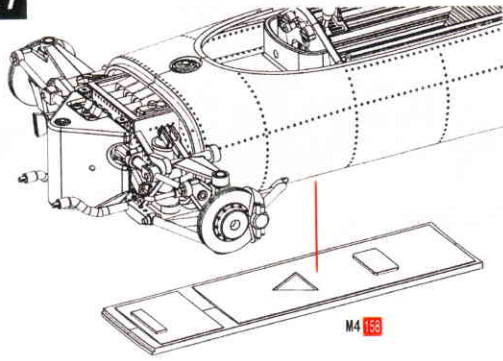

28

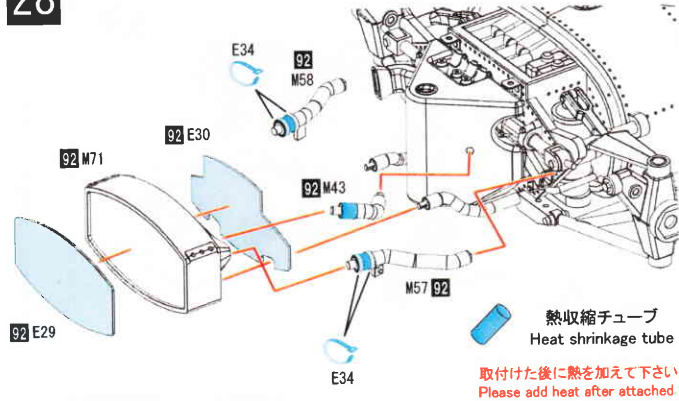

熱収縮チューブ  
Heat shrinkage tube

取付けた後に熱を加えて下さい。  
Please add heat after attached.

29

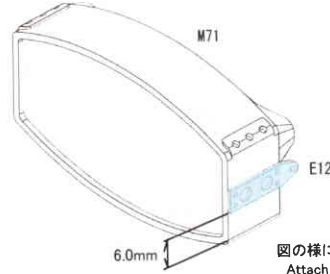
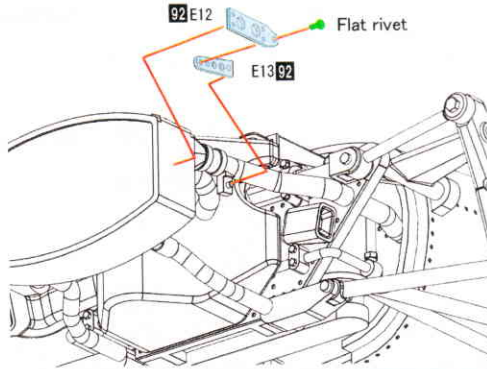

図の様に取付けます。  
Attach as shown.

反対側も同様に取付けます。  
Please assemble both sides also as shown.

30

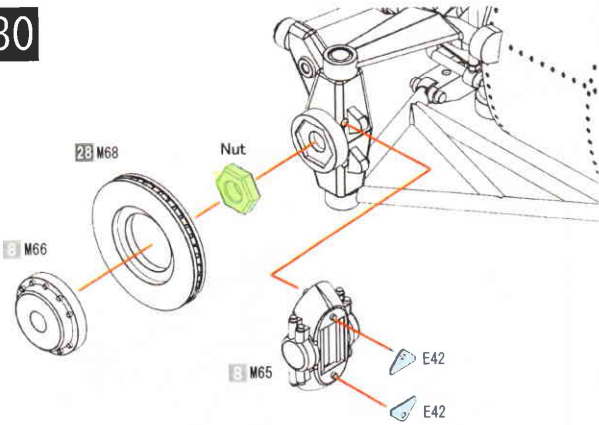

31

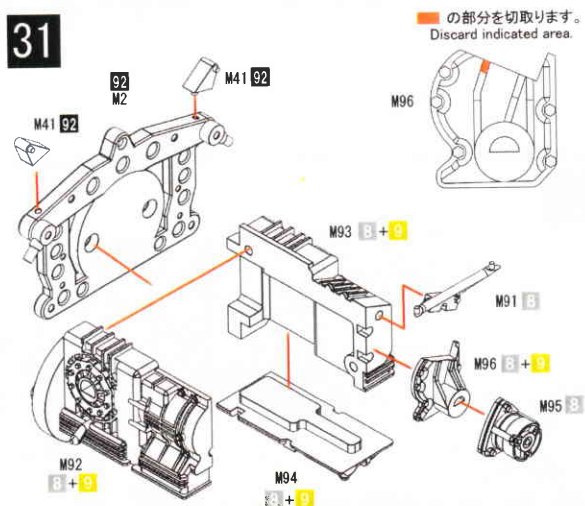

の部分を切り取ります。  
Discard indicated area.

32

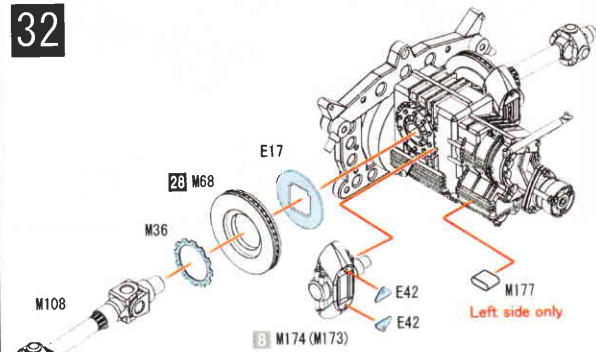

Left side only

33

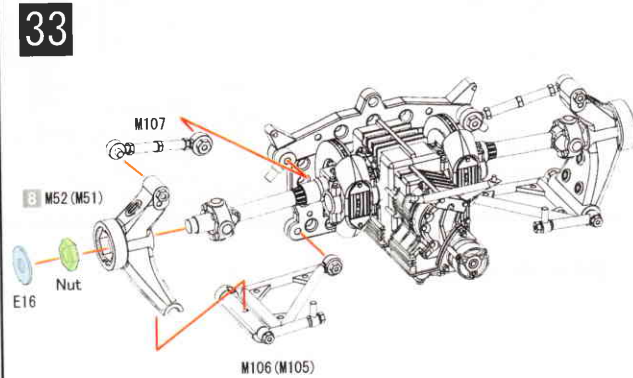

( )内は反対側のパーツ番号です。  
Numbers inside ( ) are the other side's parts number.

34

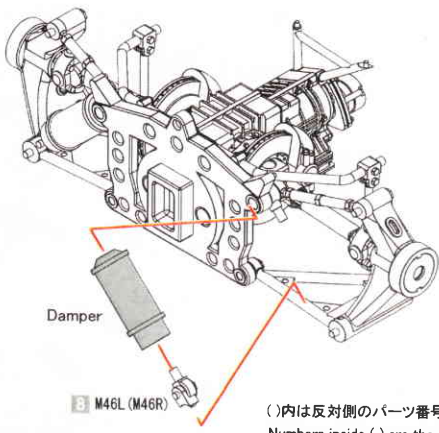
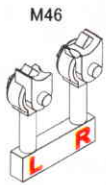

Damper

3 M46L (M46R)

( )内は反対側のパーツ番号です。  
Numbers inside ( ) are the other side's parts number.

35

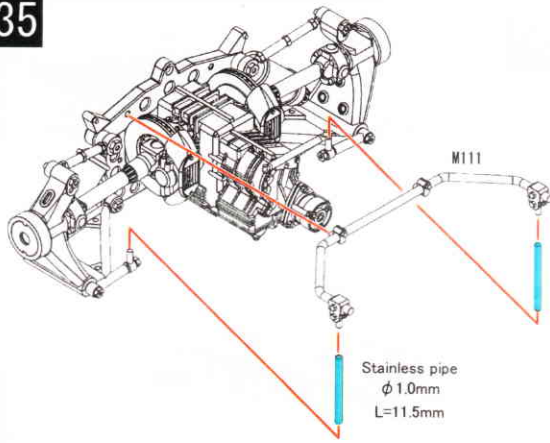

Stainless pipe  
φ 1.0mm  
L=11.5mm

36

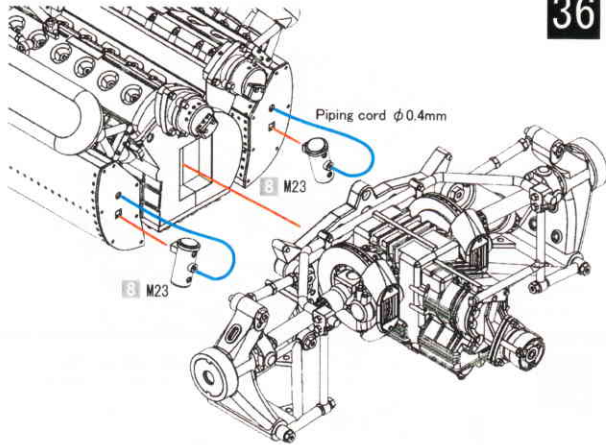

Piping cord φ0.4mm

3 M23

37

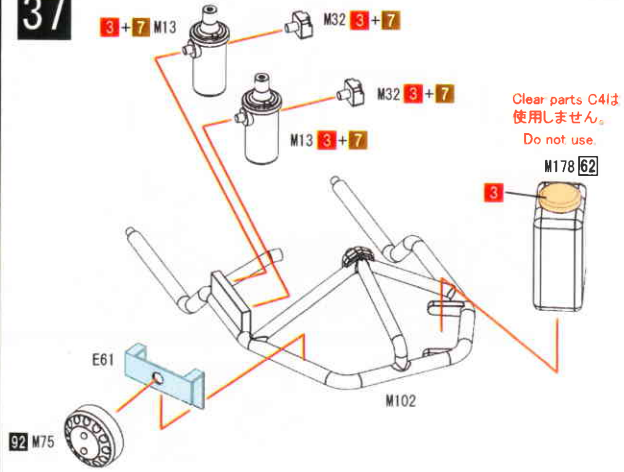

Clear parts C4は  
使用しません。  
Do not use.

3

M178 62

E61

M102

92 M75

38

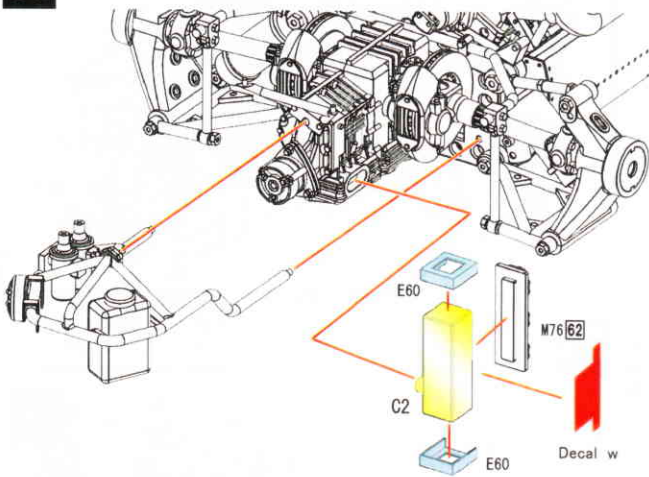

C2

E60

M76 62

Decal w

39

< Piping >

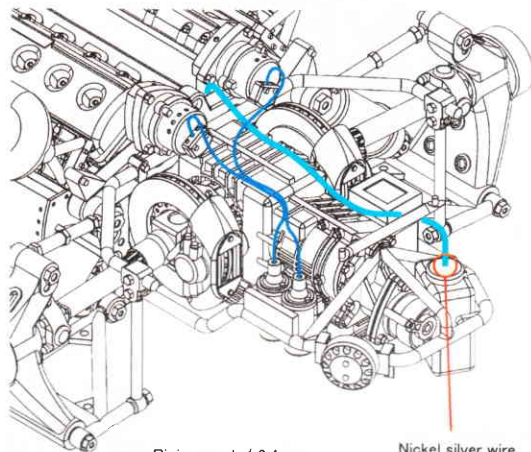

Piping cord φ 0.4mm  
Clear tube φ 0.8mm

Nickel silver wire  
φ 0.5mm  
L=2.0mm

図の様に折り曲げます。  
Bend as shown.

< Actual size >



E46



E56



< Actual size >





40

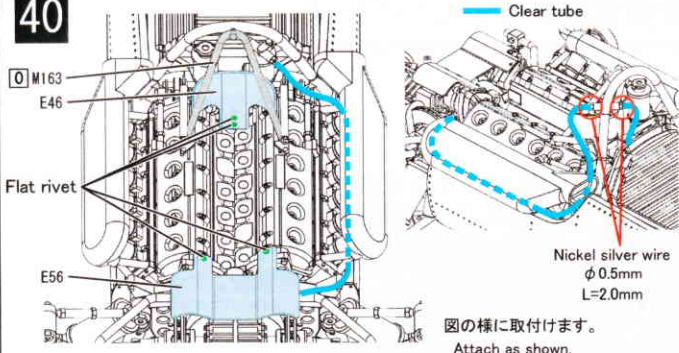

41

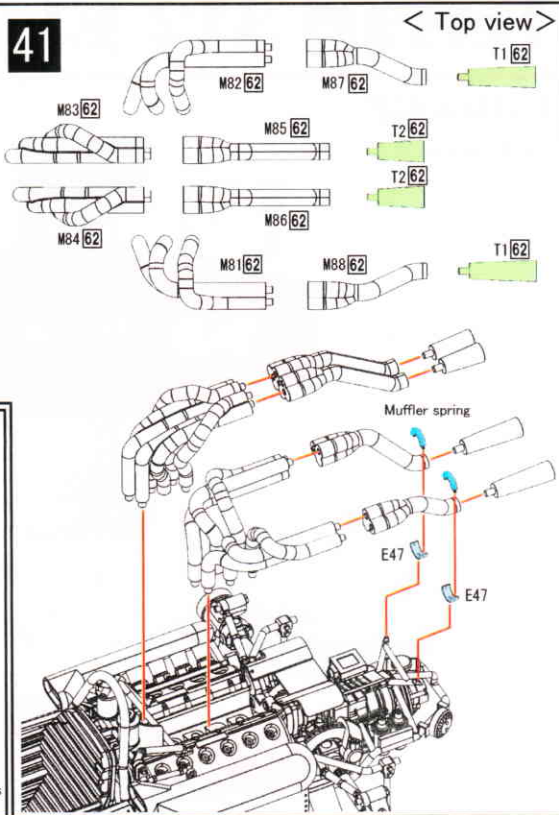

42

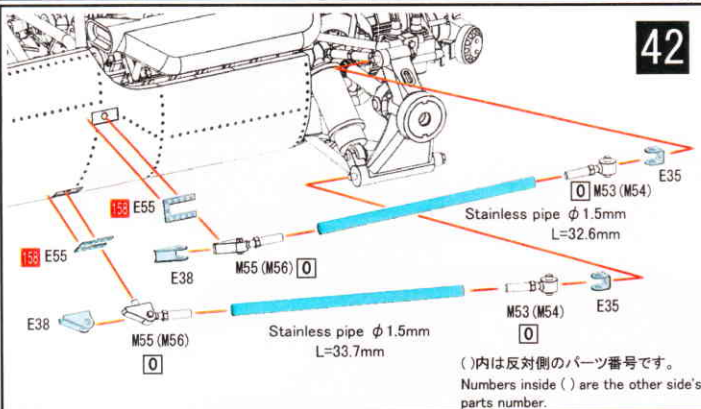

43

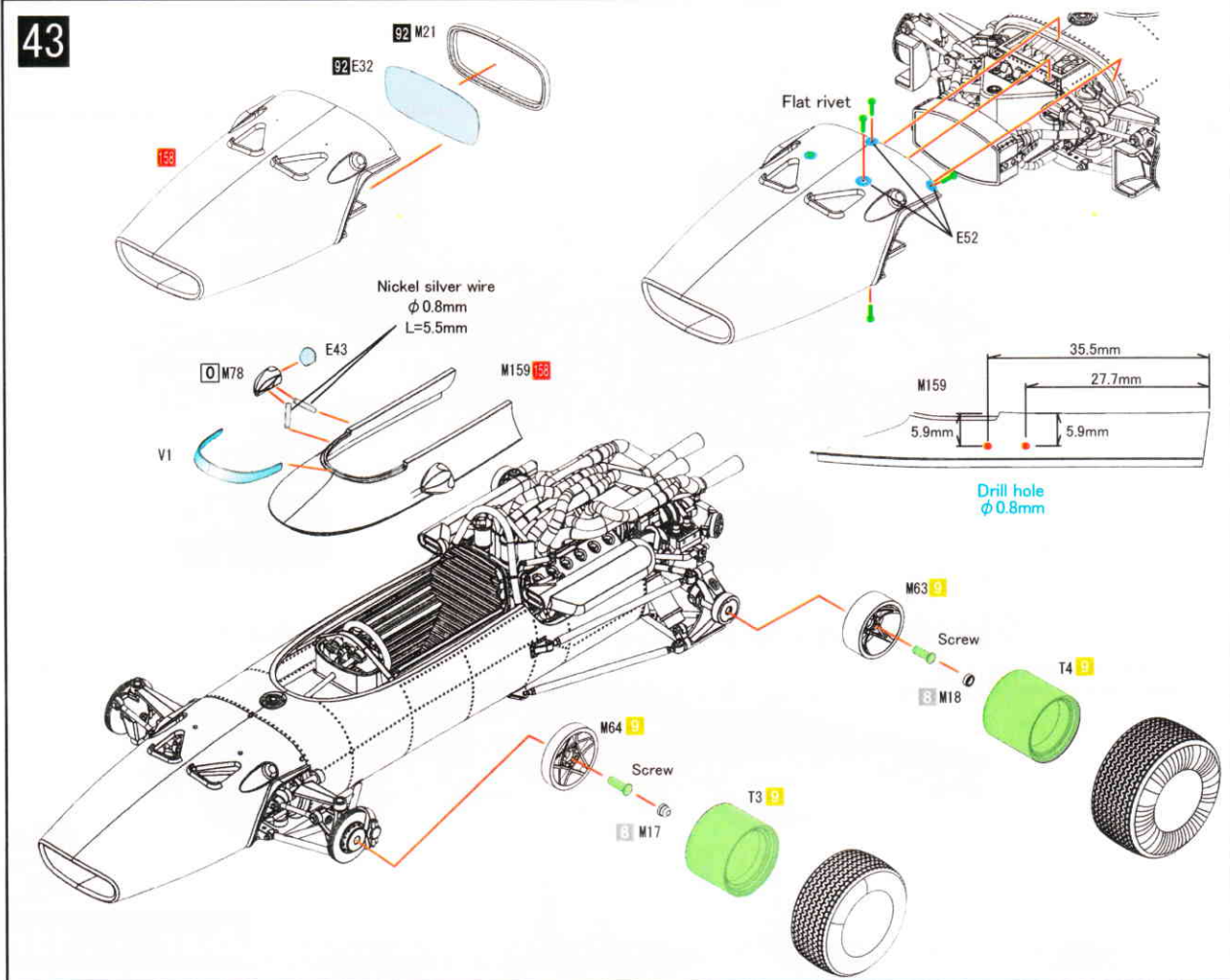

# Ferrari 312 F1 — 1967 —

## Italian GP

#2 C.Amon

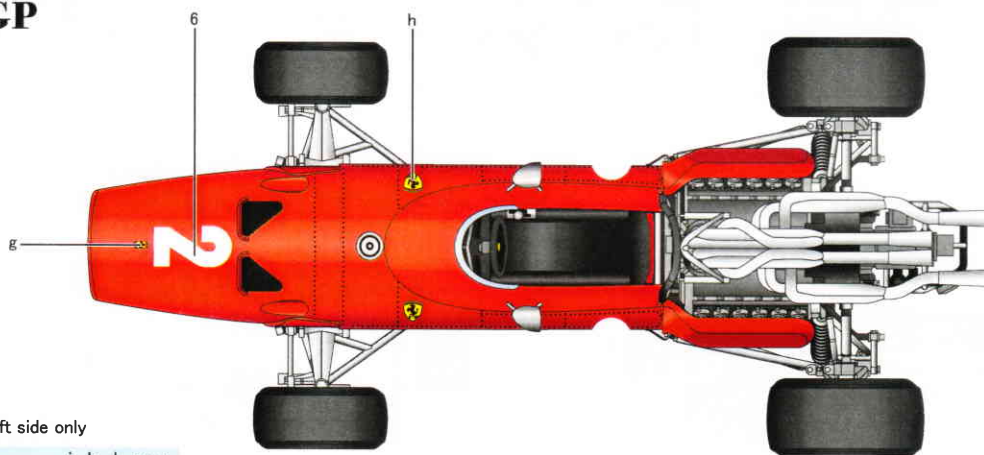

Left side only

		j	k	l	m	n
t	CO	1	2	3	4	5
i	W	6	7	8	9	10
u	11	12	13	14	15	16
v	17	18	19	20	21	22

お手持ちの資料を参考に貼って下さい。  
Please refer to the material which you have.



## US GP

#9 C.Amon

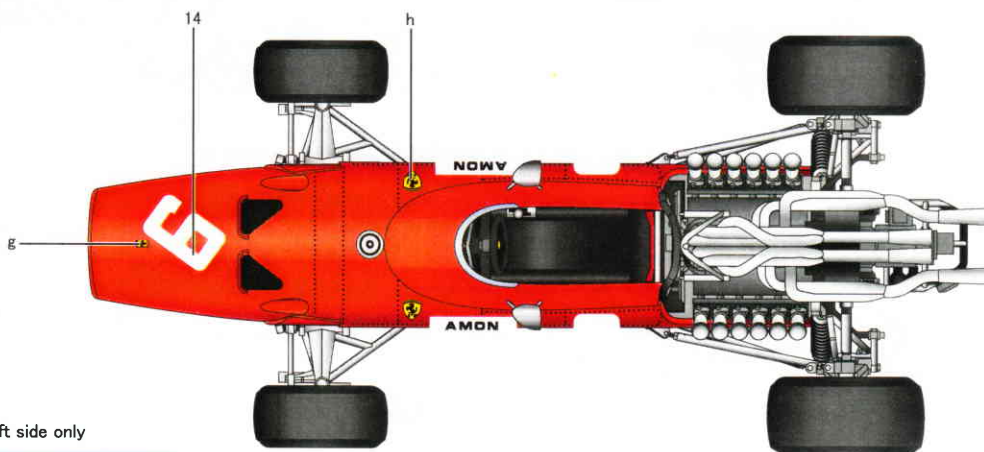

Left side only

		j	k	l	m	n
t	CO	1	2	3	4	5
i	W	6	7	8	9	10
u	11	12	13	14	15	16
v	17	18	19	20	21	22

お手持ちの資料を参考に貼って下さい。  
Please refer to the material which you have.

