

九七T後期



97T

Rate type.

Model Factory HIRO

Model Factory HIRO

東京都 足立区 青井 5-10-2
TEL 03-3852-2009 FAX 03-3852-2062

5-10-2 Aoi Adachi-ku, Tokyo JAPAN
TEL +81-3-3852-2009 FAX +81-3-3852-2062

E-mail ANA54928@nifty.com

The following are the CAD soft wear.
Model factory HIRO use NEOFORM and
Microstation Modeler to design the
kit and the instruction.

NEOFORM
MicroStation
BENTLEY Modeler

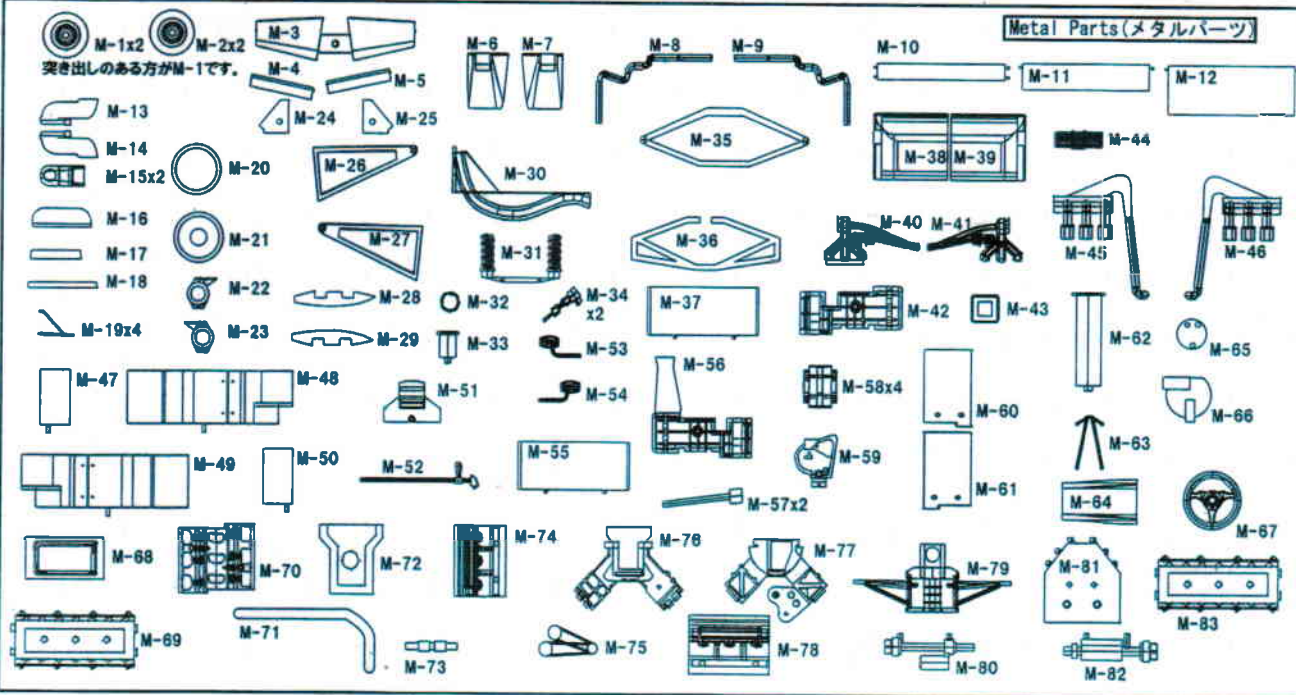
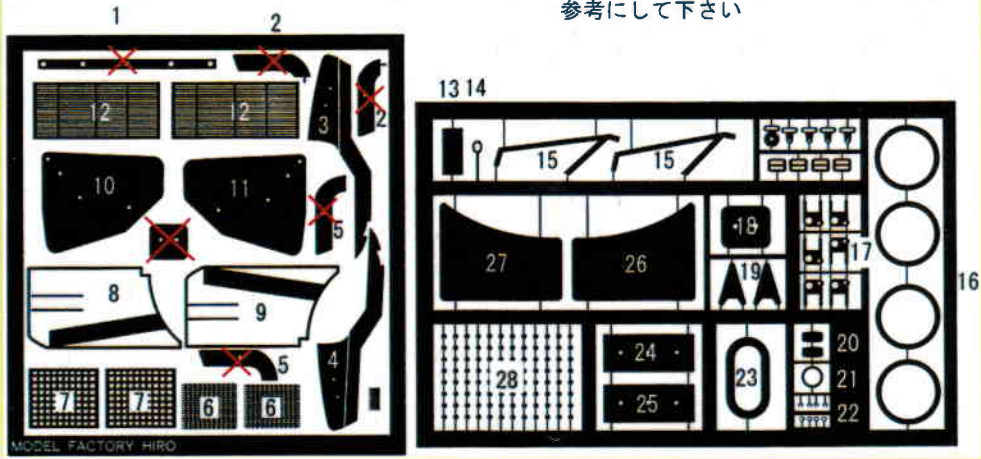

Photo etched parts

エッチング自体に付いている番号は無視して下さい。この用紙の番号を参考にして下さい

Color table 色記号表

- B-1 black
- B-2 .. semigloss black
- B-3 flat black
- B-4 clear red
- B-5 gold
- B-6 flat aluminium
- B-0. polish(磨きだし)



Other parts(その他のパーツ)

- | | |
|-----------------------------------|-------------------------------|
| Body (ボディ) x1 | Brass rod (真鍮棒) x1 |
| Chassis (シャシー) x1 | Screw (black) (黒ねじ) x10 |
| Chassis side (シャシー横) x2 | Screw (silver) (銀ねじ) x3 |
| Monococue (モノコック) x1 | Seatbelt (シートベルト) 1set |
| Stoplamp (テールランプ) x1 | Decal (デカール) 1set |
| Windshield (カウル) x1 | Rivet (リベット) x2 |
| Wheeldish (ホイールディッシュ) x4 | Piping tube (コード) 1set |
| Front wheelrim (Fホイールリム) x2 | |
| Rear wheelrim (Rホイールリム) x2 | |

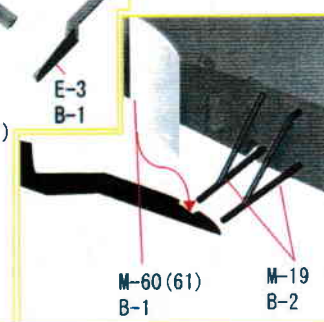
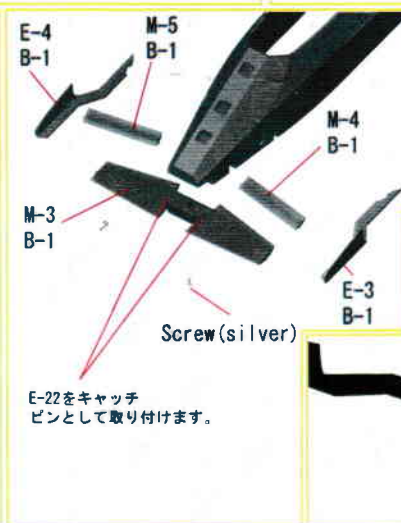
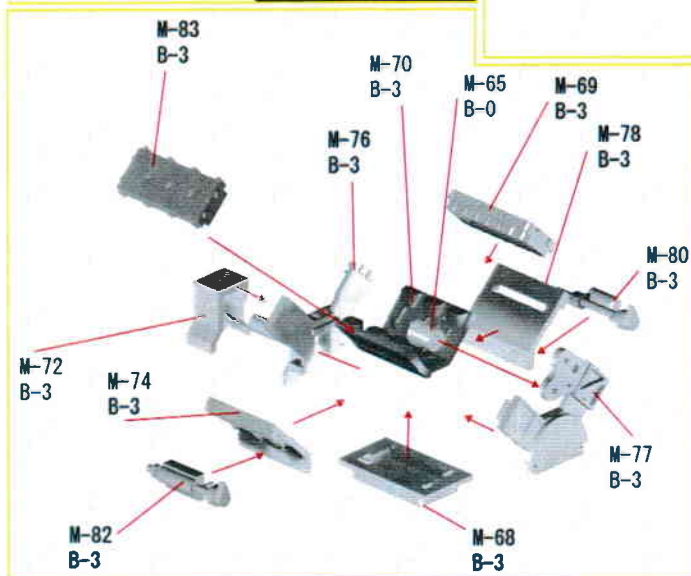
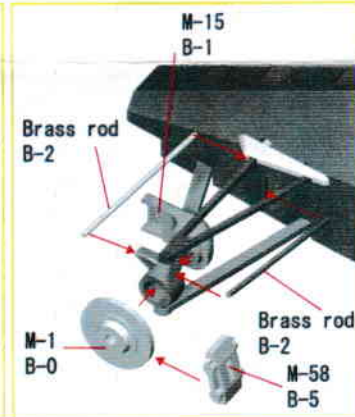
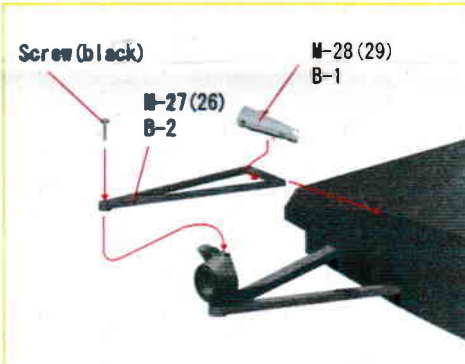
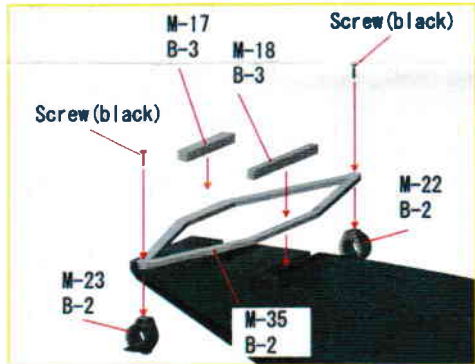

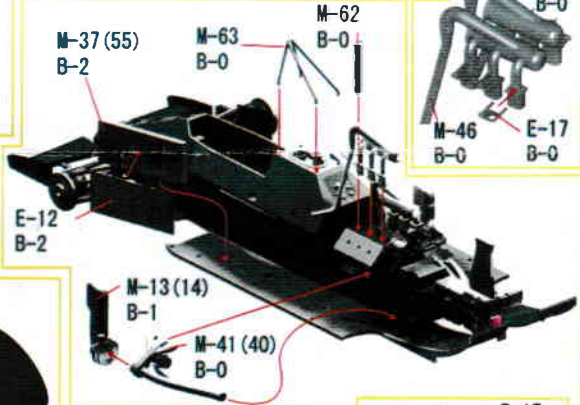
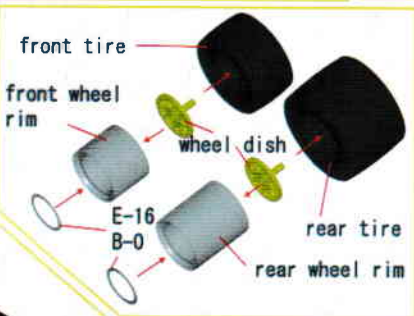
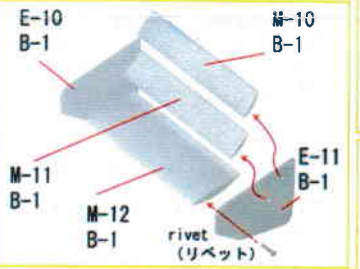
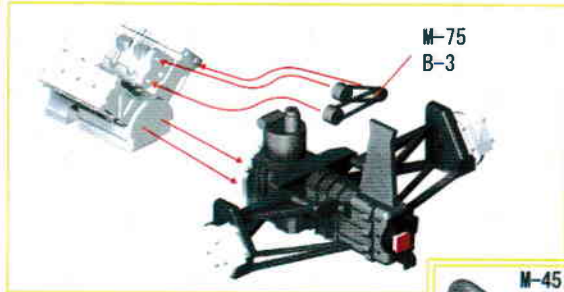
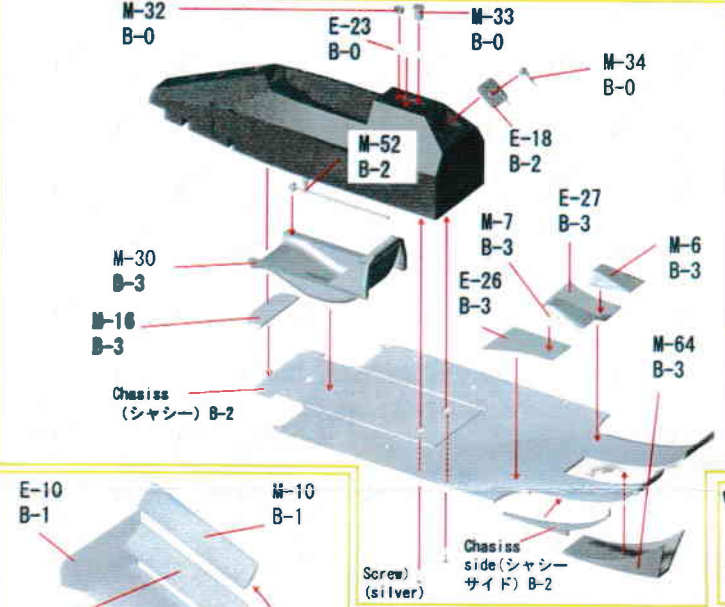
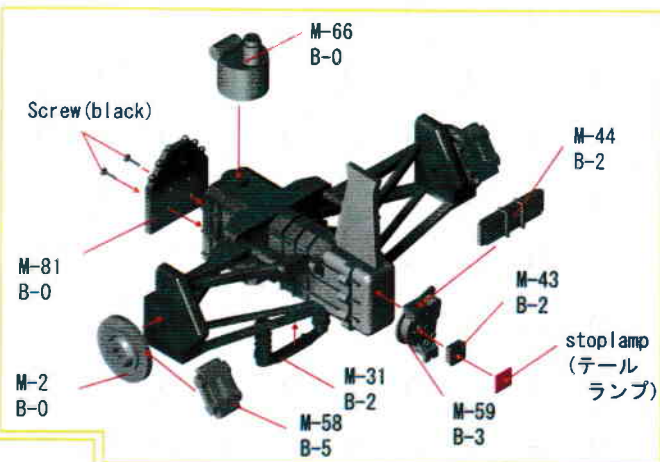
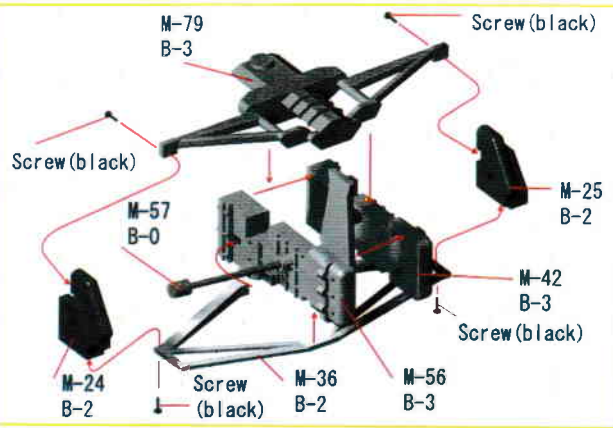

Please use M-20, 21 as base of chassis. M-71, 73 are for piping.
M-20, 21はシャシーのベースとして、M-71, 73は、パイピングにお使いください。

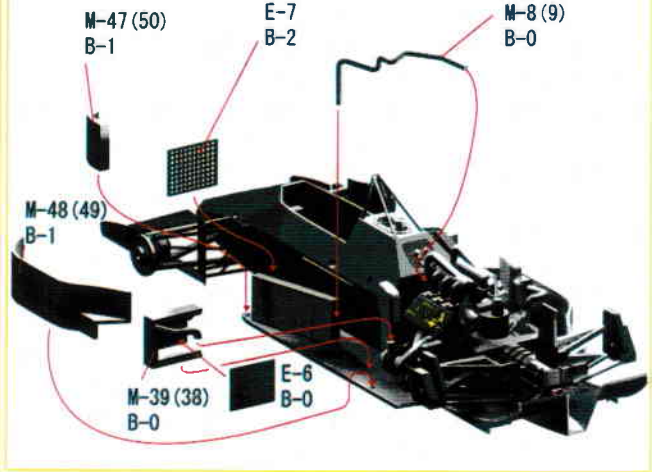
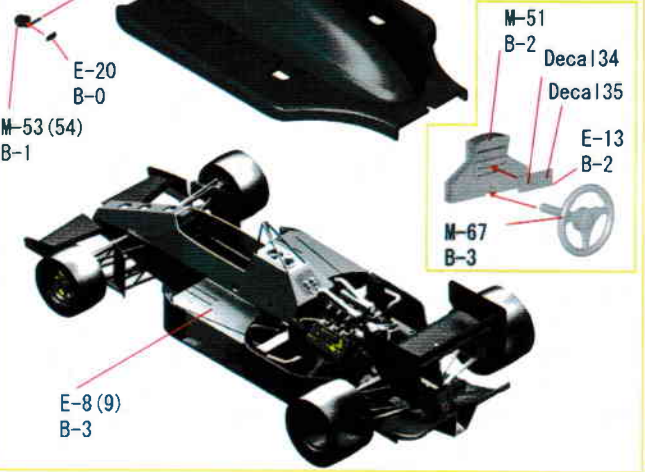

Decal

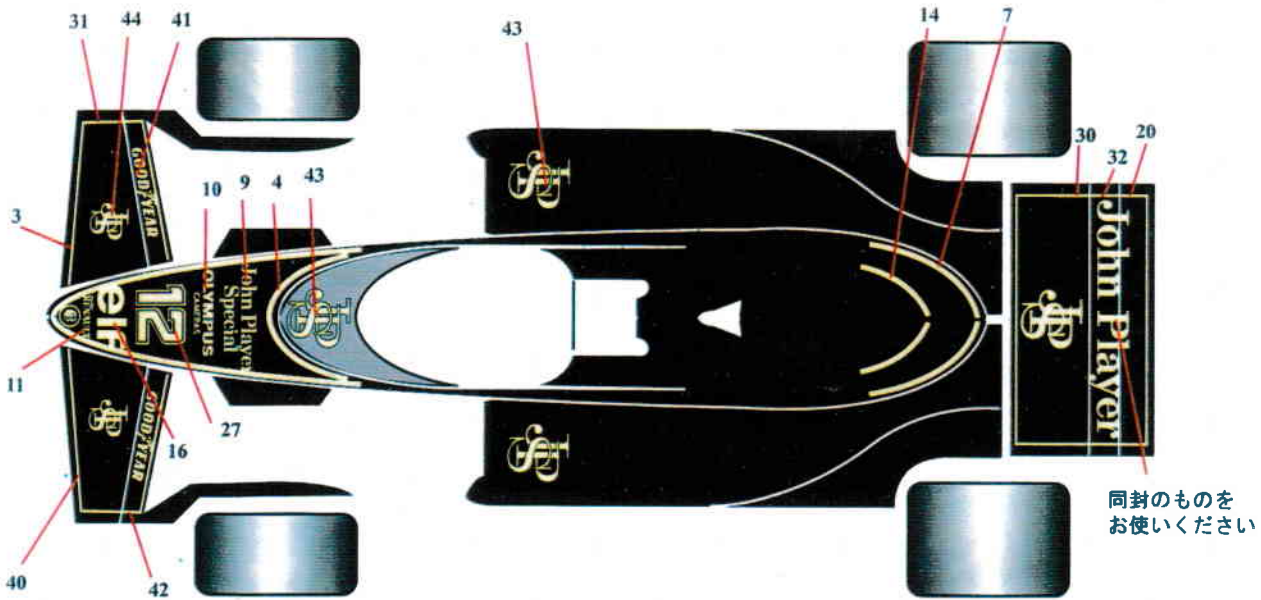

同封のものをお使いください

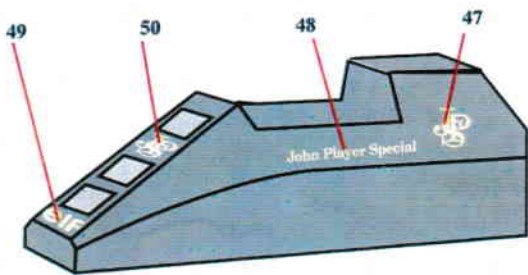
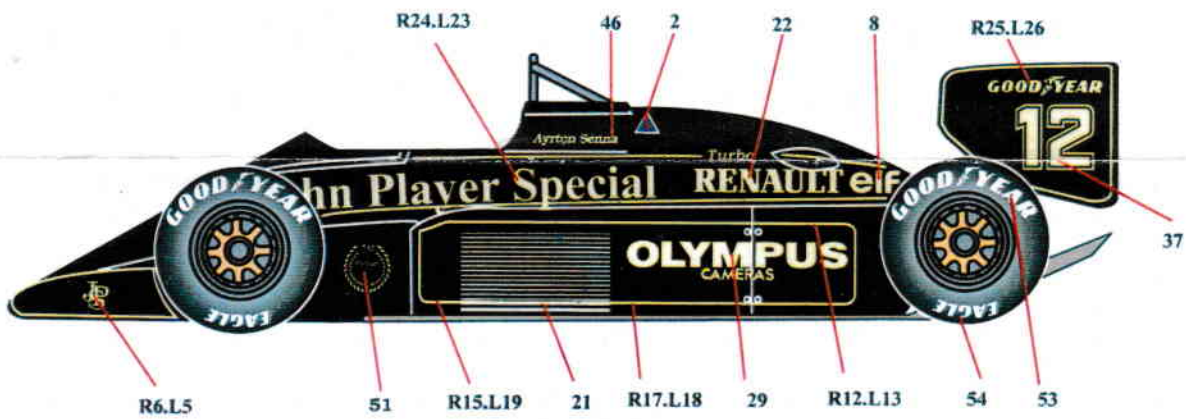

Back side of rear wing
リアウイング裏

その他のデカールはおまけです

お詫びと訂正

右図、デカールNo26が、今回微妙な版ずれを起こしており使用できないので、別納の同じデカールをお使い下さい。

