

Model Factory HIRO

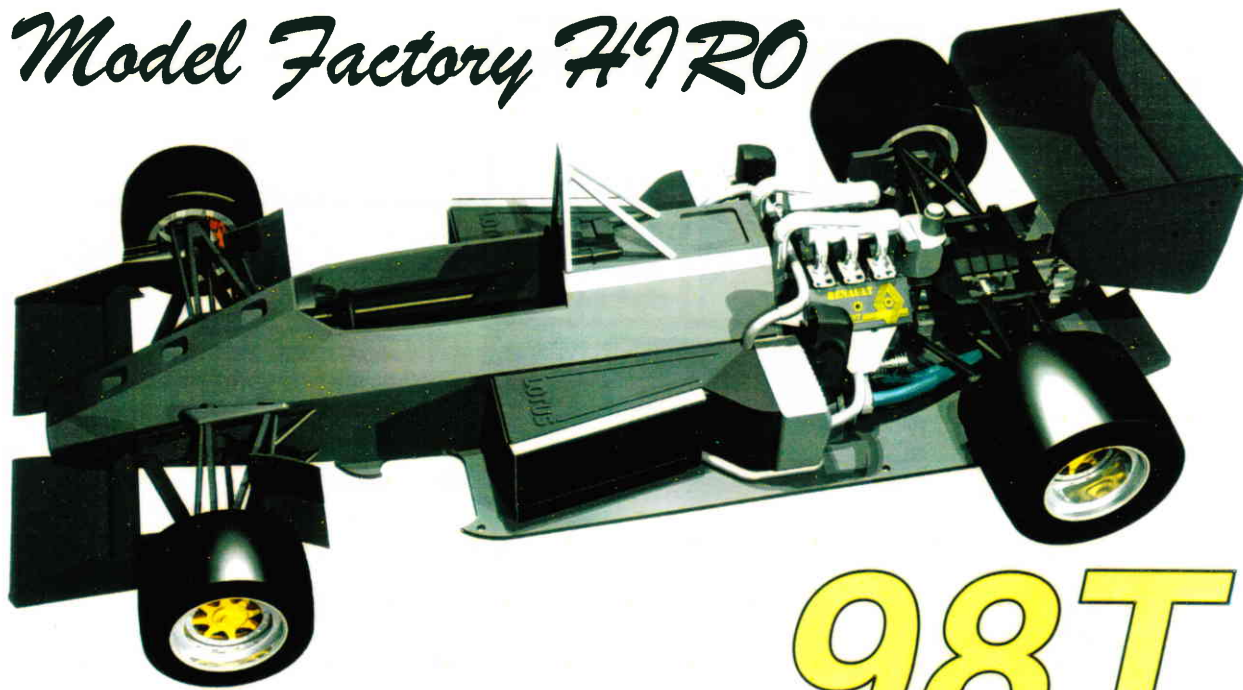

98T

Model Factory HIRO

東京都 足立区 青井 5-10-2
 TEL 03-3852-2009 FAX 03-3852-2062
 5-10-2 Aoi Adachi-ku Tokyo JAPAN

TEL +81-3-3852-2009 FAX +81-3-3852-2062

E-mail ANA54928@nifty.com

The following are the CAD soft wear.
 Model factory HIRO use NEOFORM and
 Microstation Modeler to design the
 kit and the instruction.

NEOFORM
 MicroStation
BENTLEY Modeler

Metal Parts (メタルパーツ)

M-11 M-12 M-46 M-47

M-41 M-48 M-49 M-50 M-51

M-52 M-53 M-54 M-55 M-56 M-57 M-58 M-59 M-60 M-61

M-62 M-63 M-64 M-65 M-66 M-67 M-68 M-69 M-70 M-71 M-72 M-73 M-74 M-75

Parts List		Parts List	
Body (ボディ).....x1	Tail lamp (テールランプ).....x1	Body (ボディ).....x1	Tail lamp (テールランプ).....x1
Chassis (シャシー).....x1	Wind shield (ウインドシールド).....x1	Chassis (シャシー).....x1	Wind shield (ウインドシールド).....x1
Tire (タイヤ).....x4	Prug cord (プラグコード).....x1	Tire (タイヤ).....x4	Prug cord (プラグコード).....x1
F wheel rim (Fホイールリム).....x2	Seat belt (シートベルト).....x1	F wheel rim (Fホイールリム).....x2	Seat belt (シートベルト).....x1
R wheel rim (Rホイールリム).....x2	Rivet (リベット).....x2	R wheel rim (Rホイールリム).....x2	Rivet (リベット).....x2
Wheel dish (ホイールディッシュ).....x4	Chassis side (シャシーサイド).....x2	Wheel dish (ホイールディッシュ).....x4	Chassis side (シャシーサイド).....x2
Monocoque (モノコック).....x1		Monocoque (モノコック).....x1	
Screw (black) (黒ネジ).....x8		Screw (black) (黒ネジ).....x8	
Screw (Silver) (銀ネジ).....x3		Screw (Silver) (銀ネジ).....x3	
Brass wire (洋白線).....x1		Brass wire (洋白線).....x1	
Brass rod (真鍮棒).....x2		Brass rod (真鍮棒).....x2	

Photo etched parts

Color table 色記号表

- B-1 black
- B-2 .. semigross black
- B-3 flat black
- B-4 clear red
- B-5 gold
- B-6 flat aluminium
- B-0. polish(磨きだし)

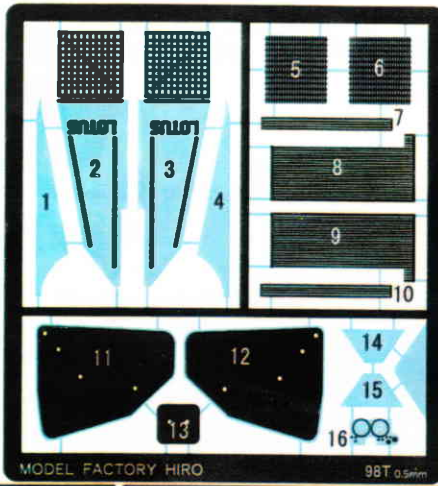

エッチング自体に付いている番号は無視して下さい。この用紙の番号を参考にして下さい

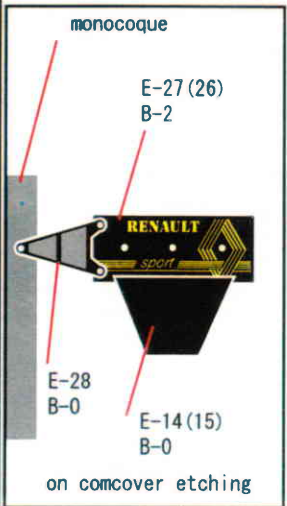
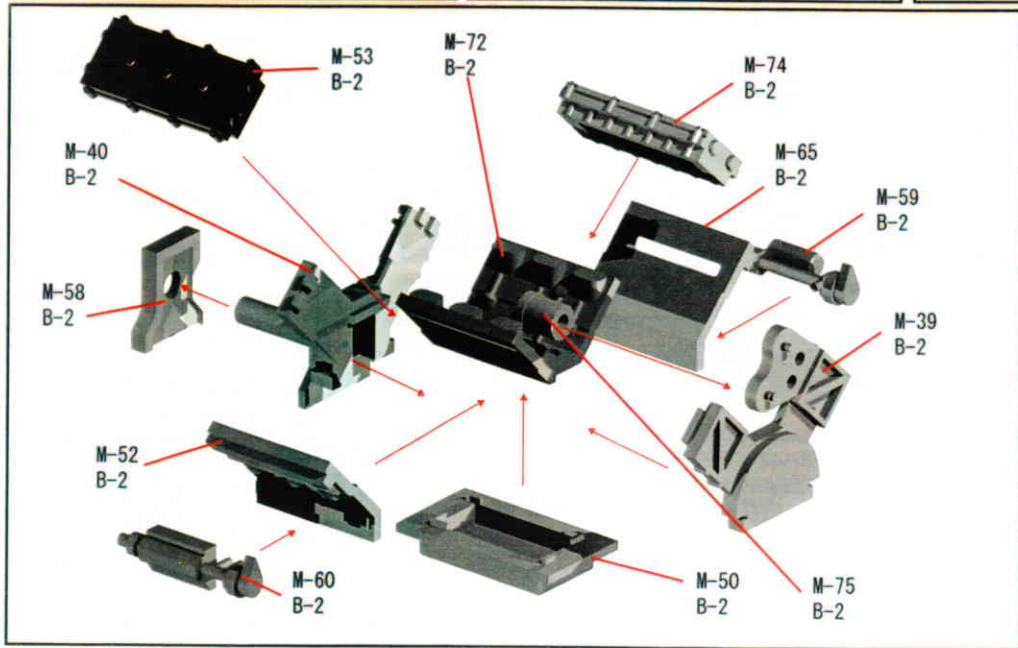
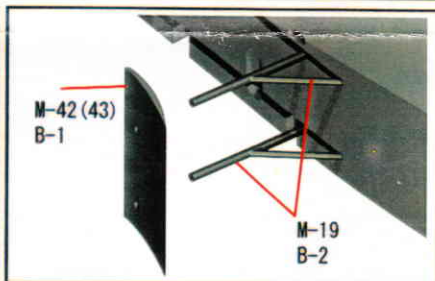
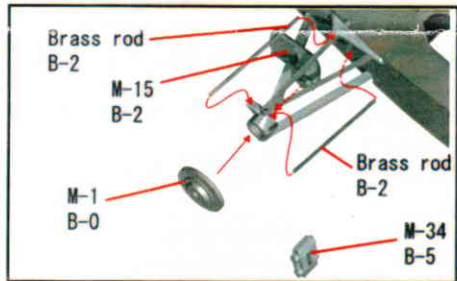
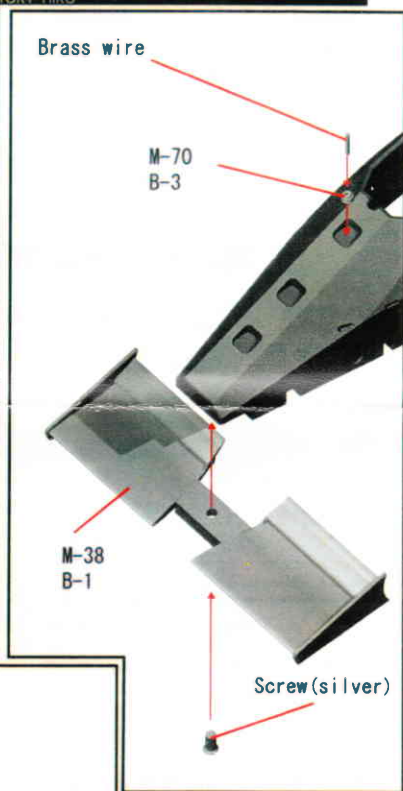
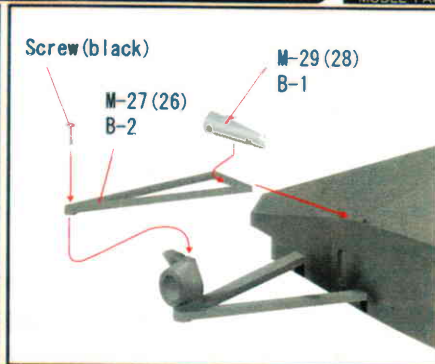
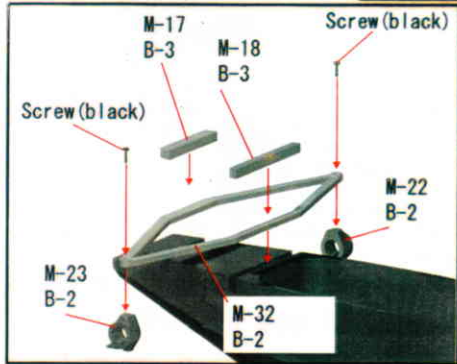
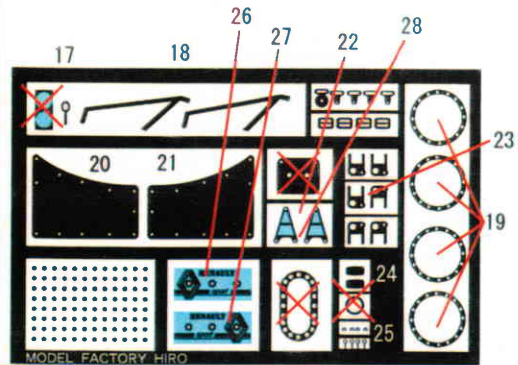

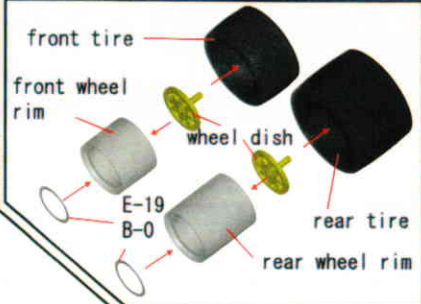
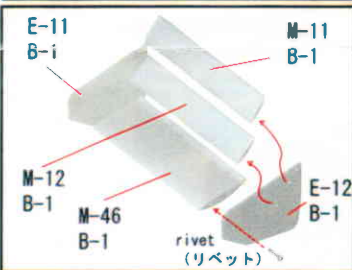
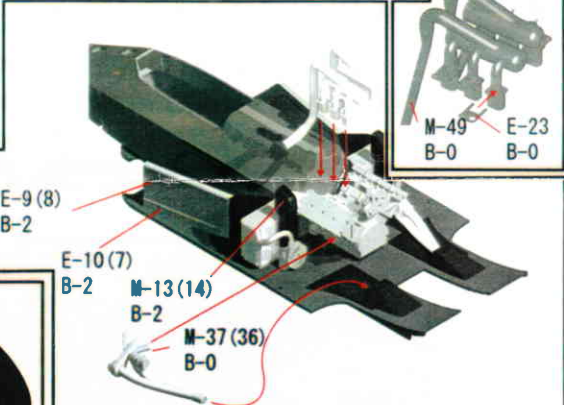
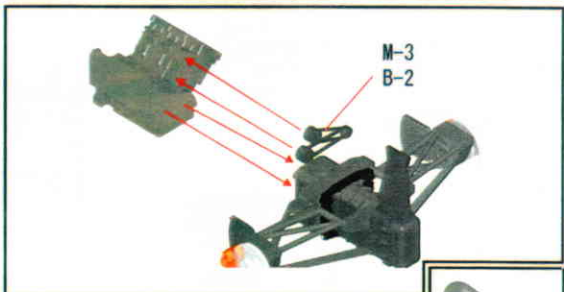
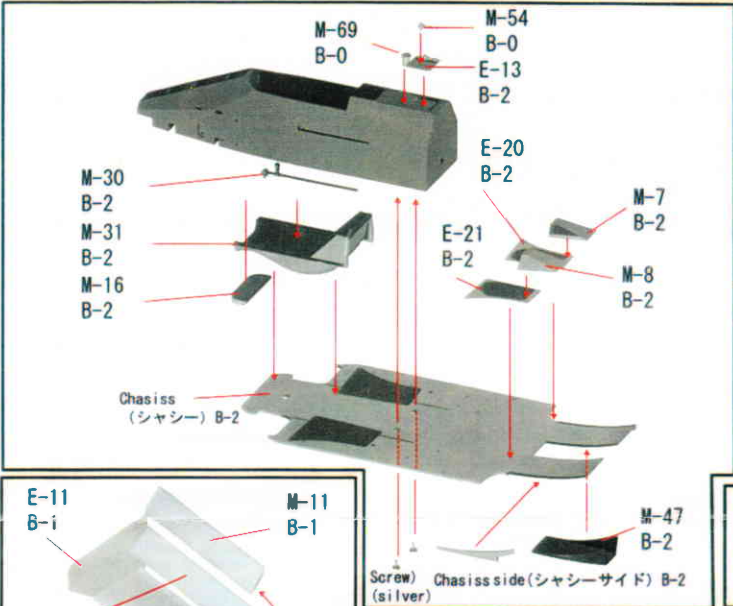
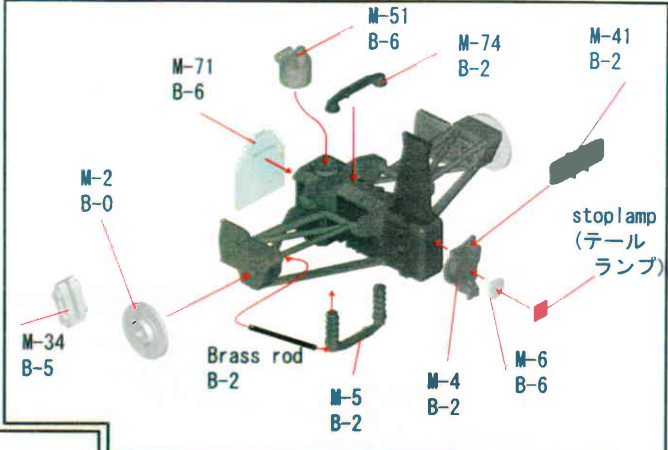
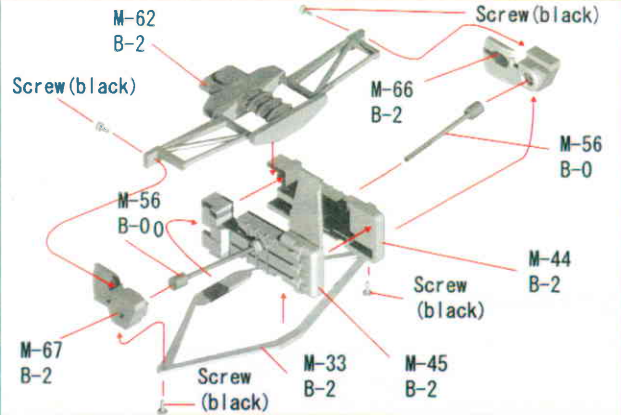

Please use M-20, 21 as base of chassis. M-55 is for piping.
 M-20, 21はシャシーのベースとして、M-55はパイピングにお使いください。

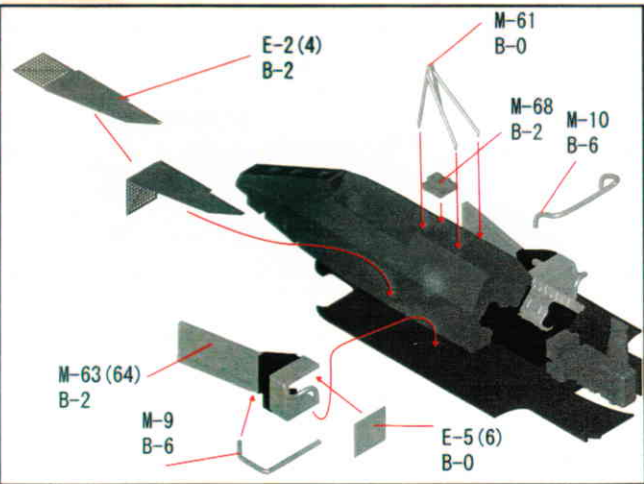
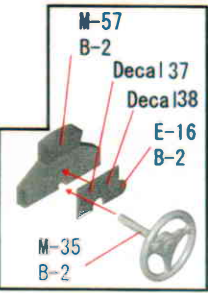
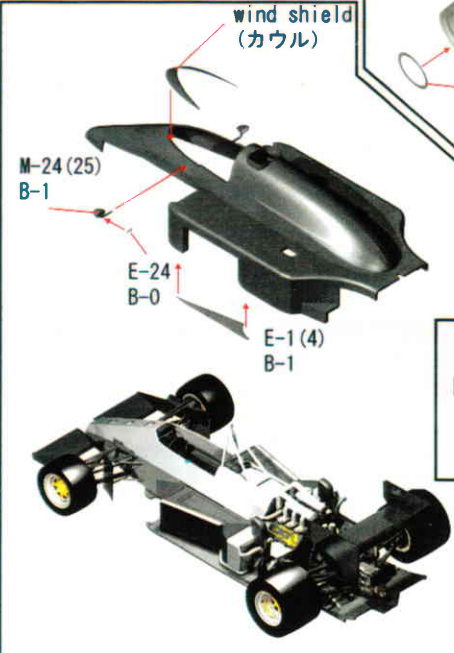
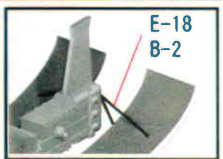

Decal

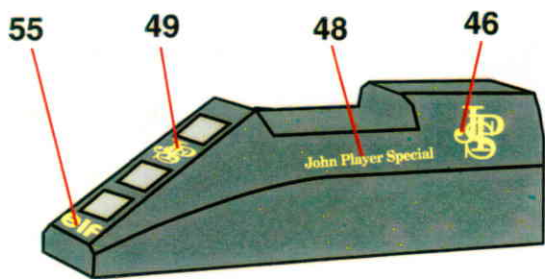
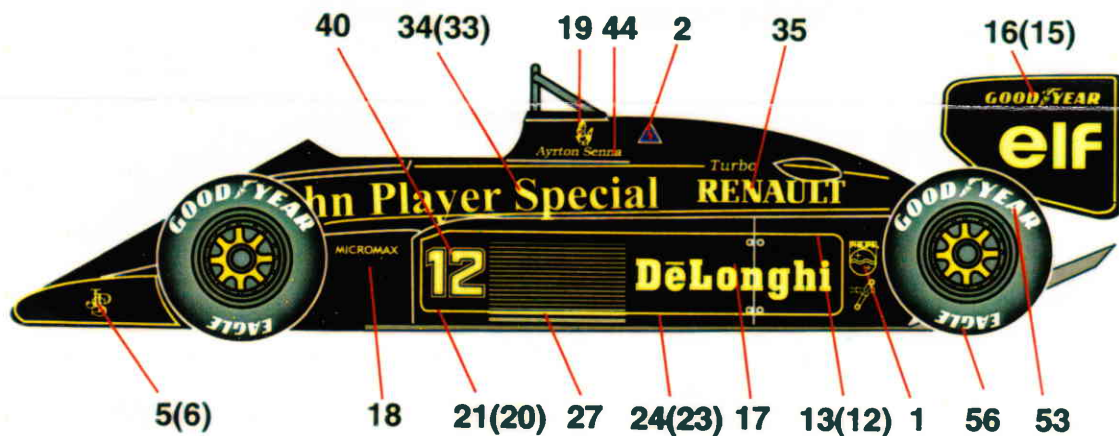
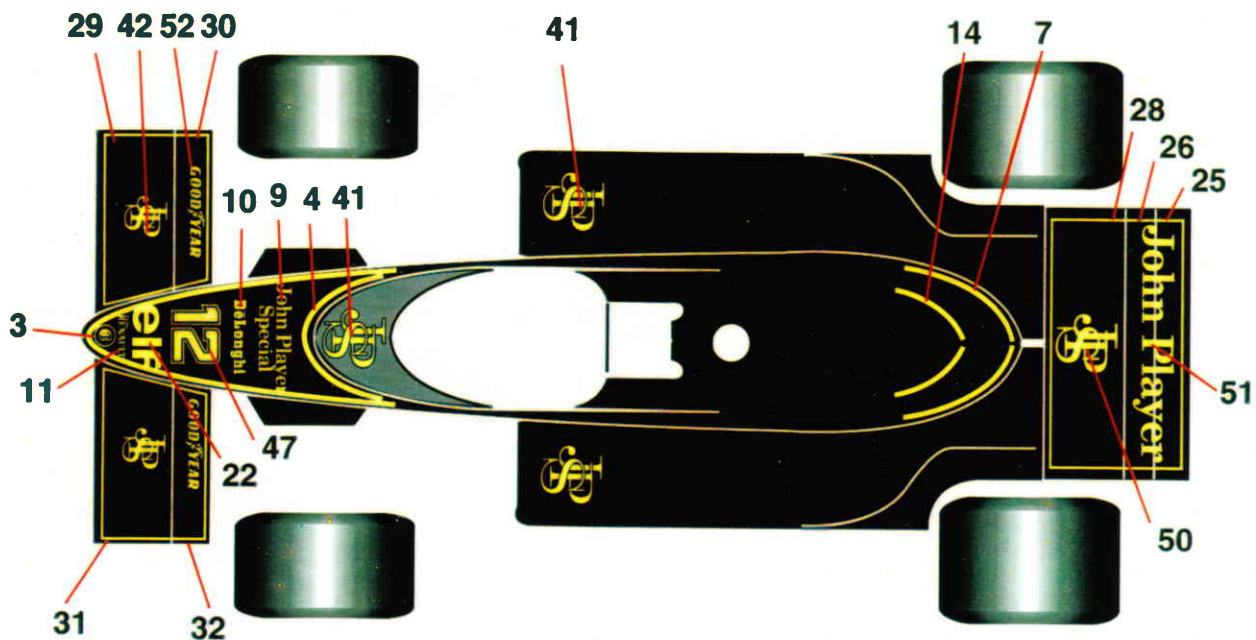

その他のデカールはおまけです