

折蝕刻片的指示線: Bend the PE part along the line
 向前摺 To bend forward 向後摺 To bend backward

Wire number 配線編號: 1

注意這些零件與車殼的配合! Pay attention to the fitting of small parts and cowling

將車頭改成圖中狀態
 Modify the shape as the figure shown

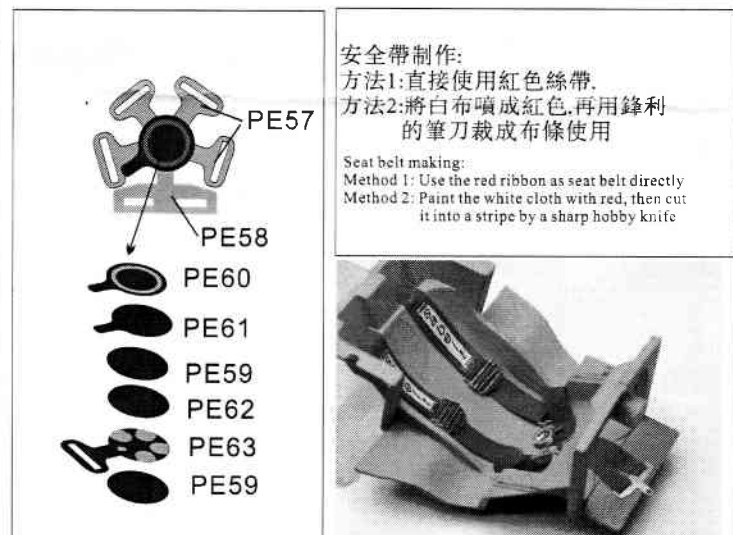
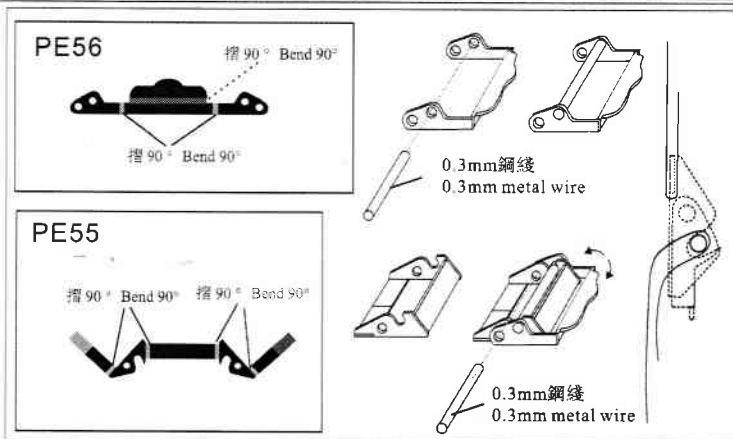
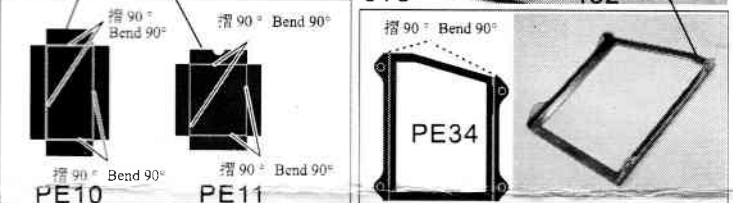
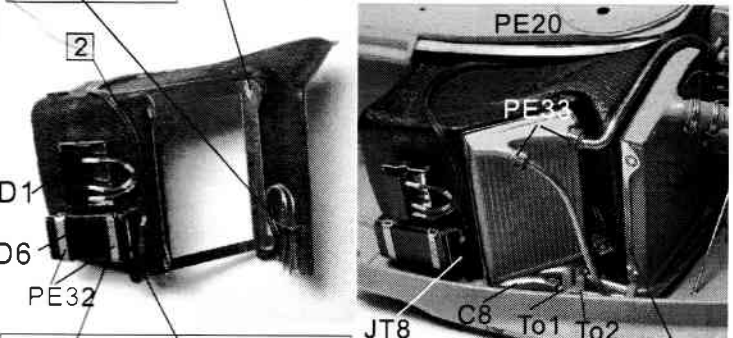
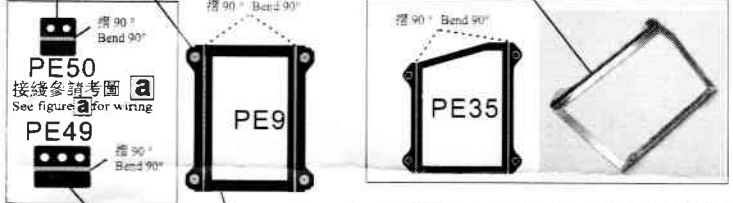
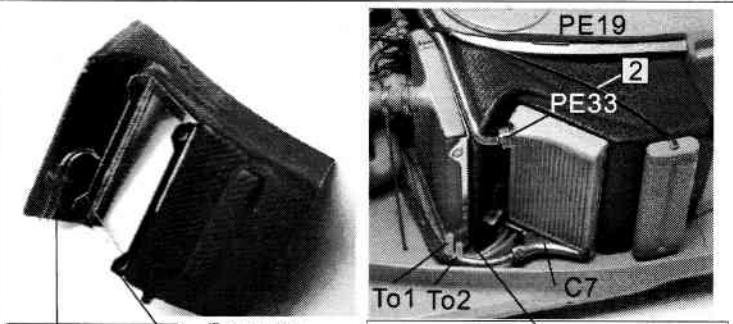
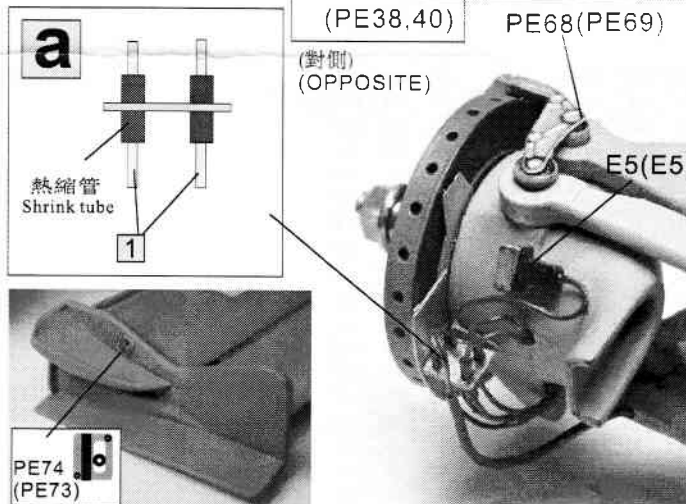
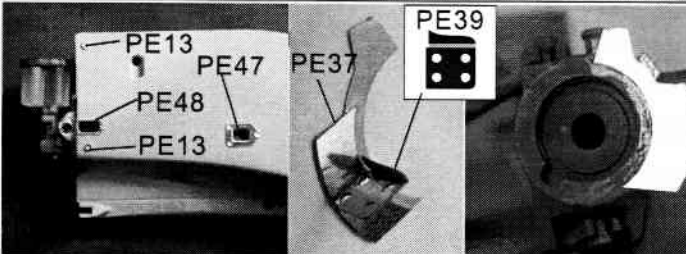
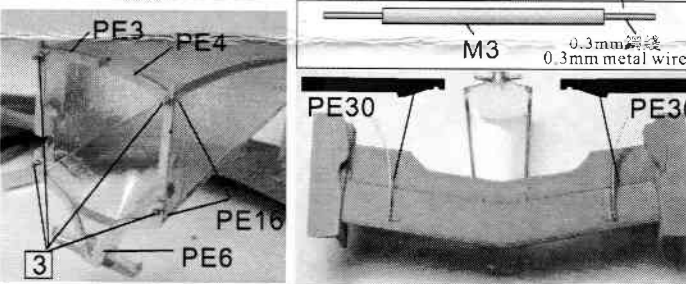
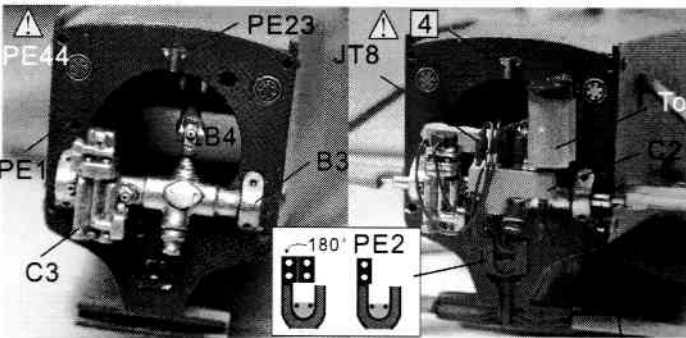
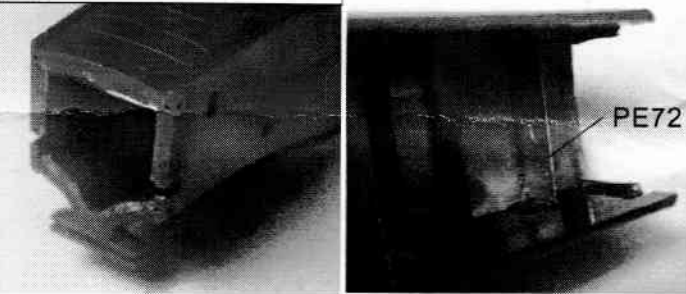

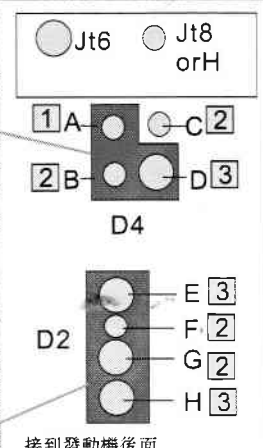
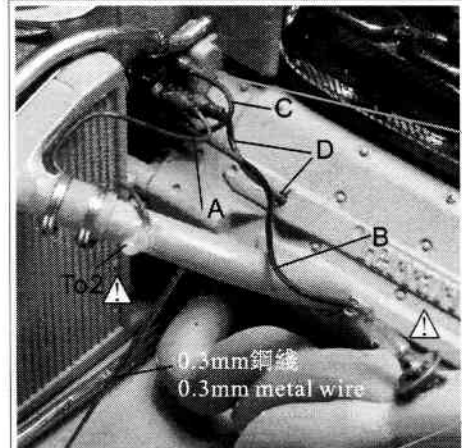
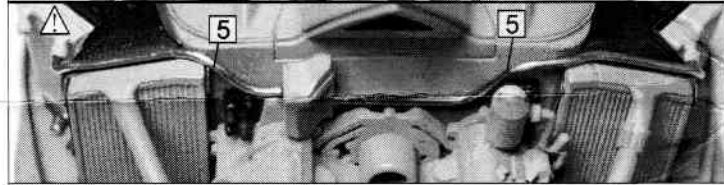
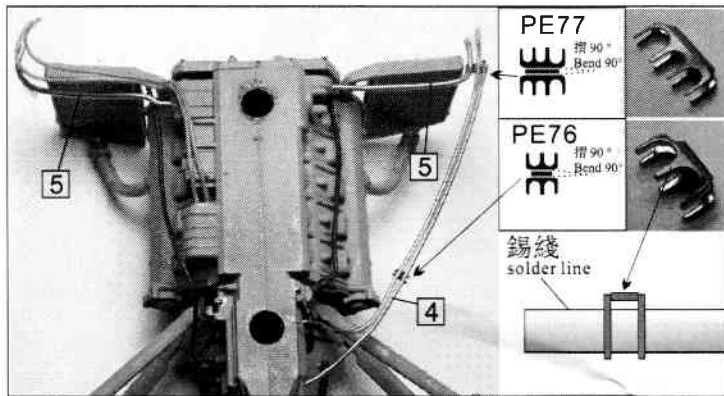

接到發動機後面
C, E, G, connect to the rear
of the engine

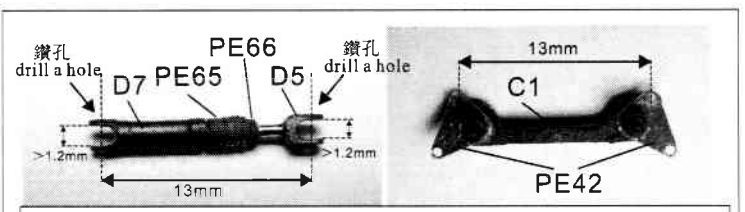
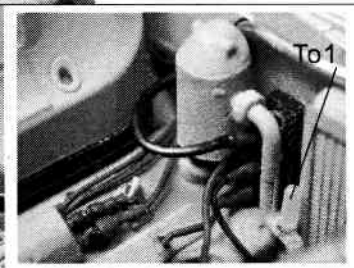
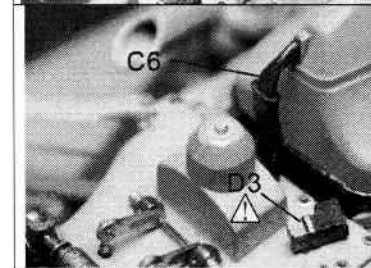
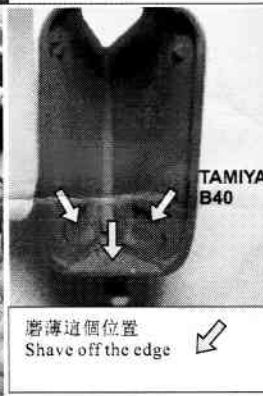
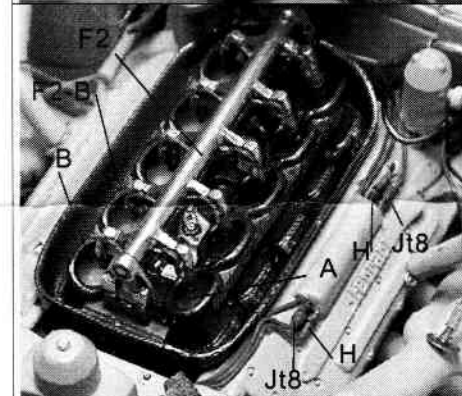
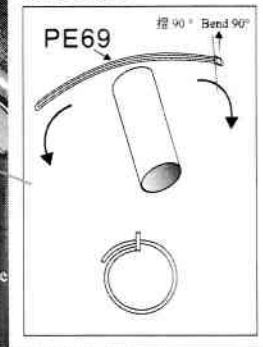
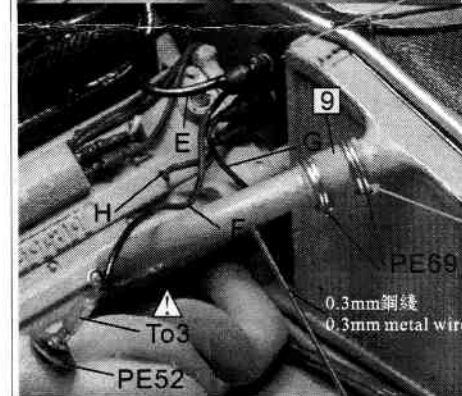

先用少量膠水固定C1和PE42，但不要粘太牢固，方便之後調整
Use little glue to lightly fix the C1 and PE42 for adjusting a right position

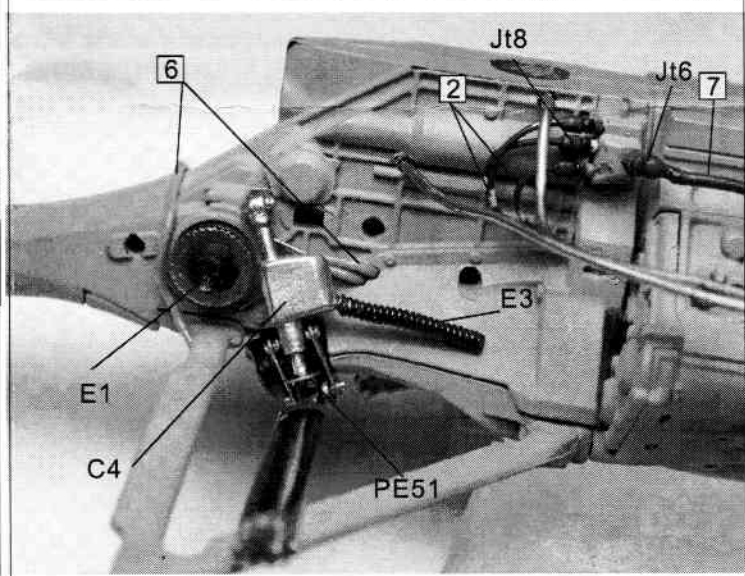
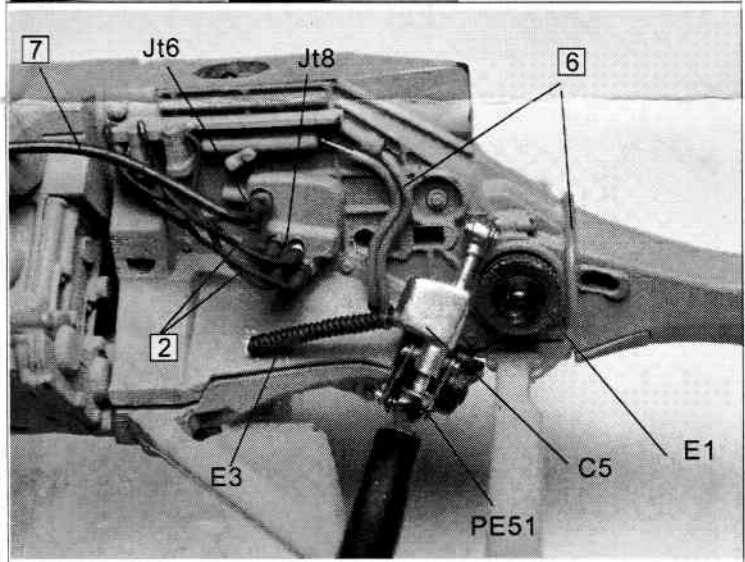
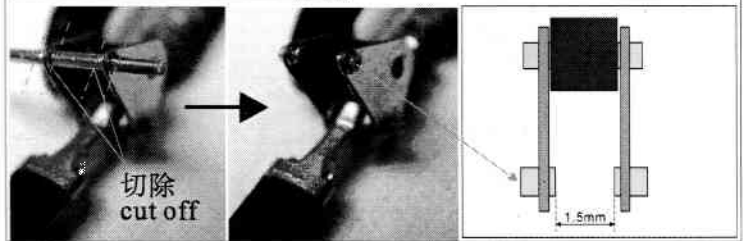
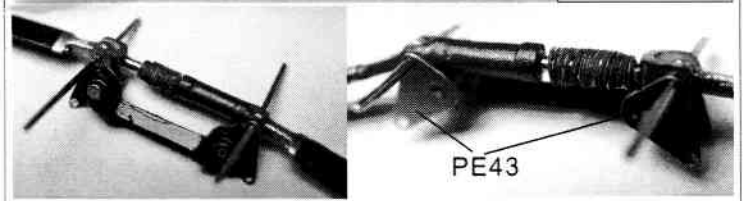
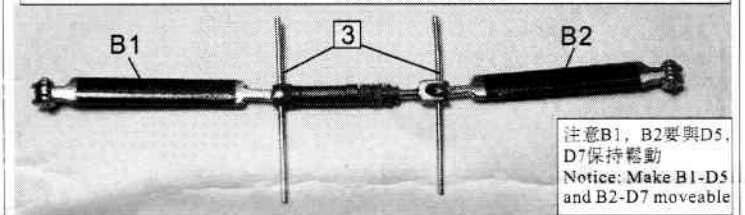

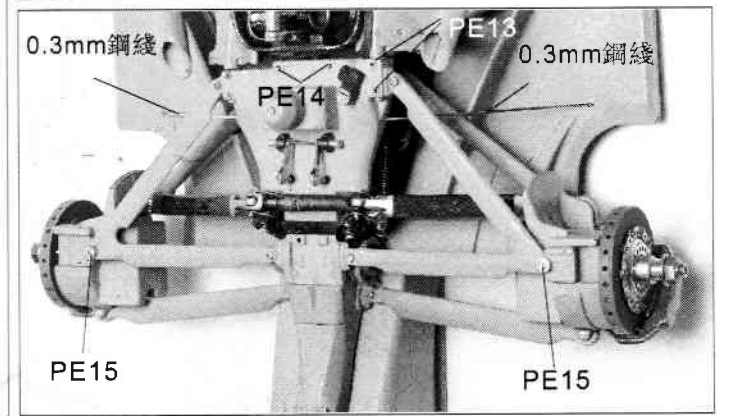
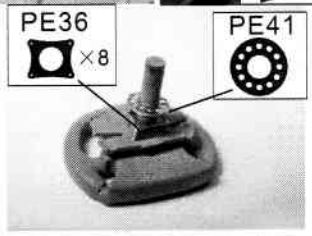
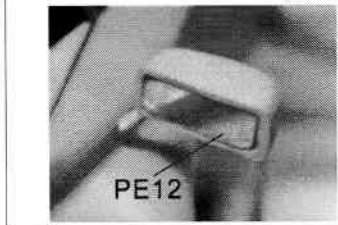
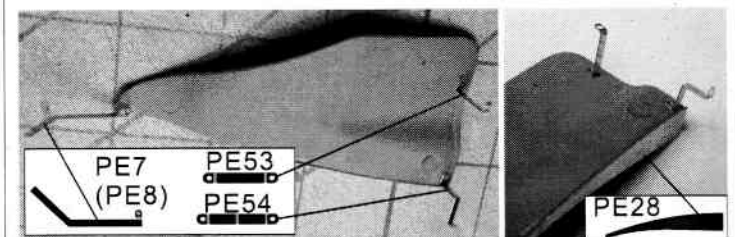
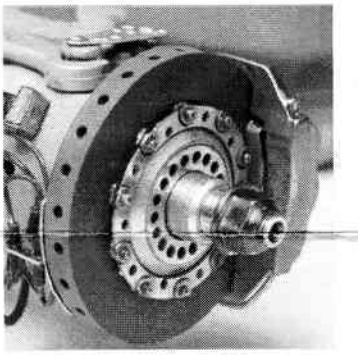
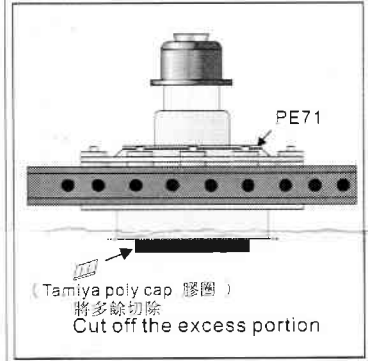
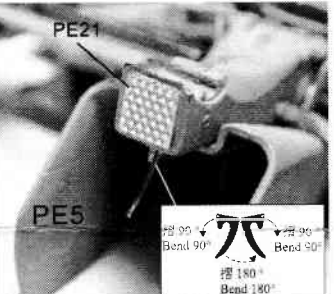
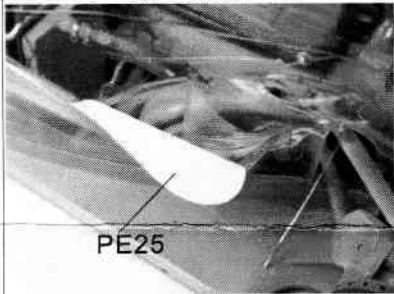
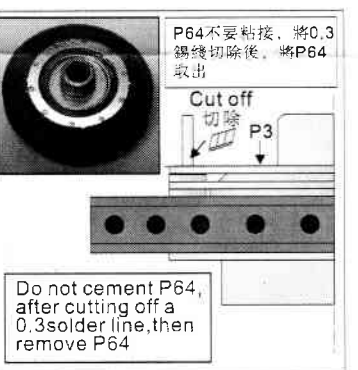
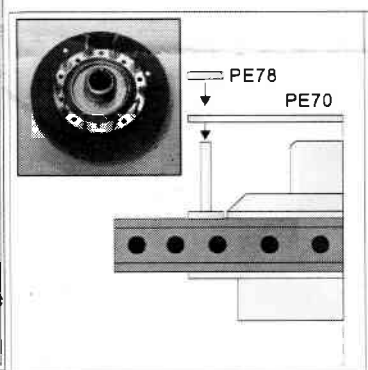
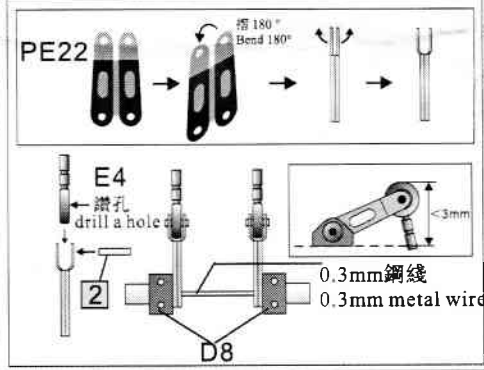
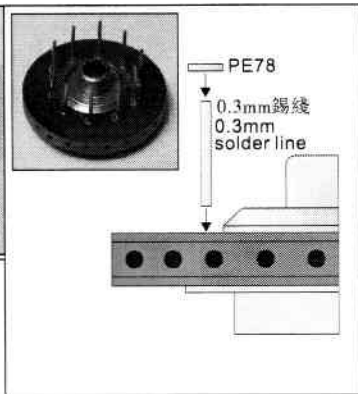
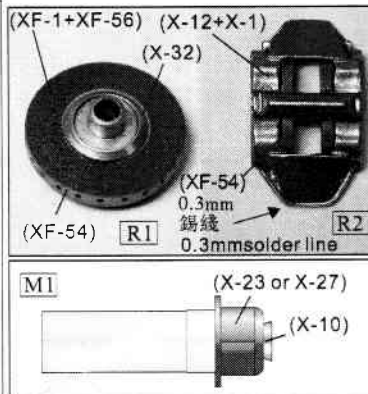
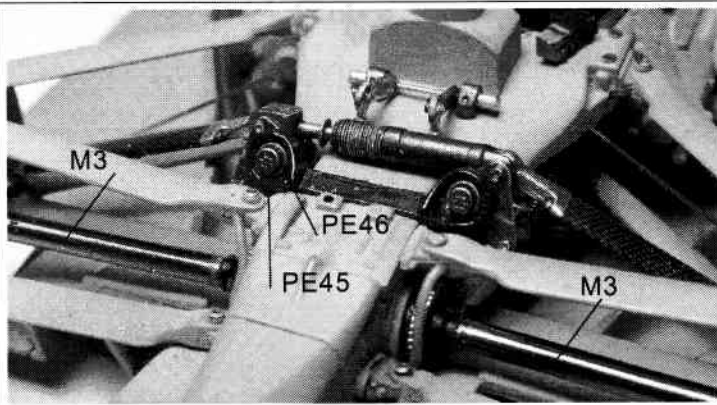

編號 number	規格 specification	數量 Quantity
1	0.2mm 金屬線 0.2mm metal wire	×1
2	0.3mm 錫線 0.3mm solder line	×1
3	0.5mm 錫線 0.5mm solder line	×1
4	0.6mm 錫線 0.6mm solder line	×1
5	0.8mm 錫線 0.8mm solder line	×1
6	藍色電線 blue wire	×1
7	黑色電線 black wire	×1
8	熱縮管 (黑) shrink tube(black)	×2
9	熱縮管 (藍) Shrink tube(blue)	×1

Using the shrink tube:
熱縮管使用:
 1. 將熱縮管均勻加熱, 加熱後, 熱縮管收縮 (此時為收縮的最大直徑)
 1. heat the shrink tube evenly, it will be shrunk (the tube now in the largest diameter)

2. 待1~2秒後, 將熱縮管拉長, 可得到更小的線徑, 拉伸越長, 線徑越小。
 2. after 1~2 seconds, stretch the tube, it will be shrunk more when stretch more

請在以下網址下載更多高解圖片及彩色說明書:
 Please download more high-resolution pictures and instruction sheets with color from below links:
<http://www.topstudiohobby.com/product/MD29003/MD29003.rar>
http://www.topstudiohobby.com/instruction/MD29003_instruction.rar

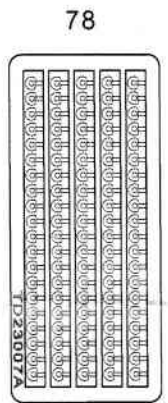
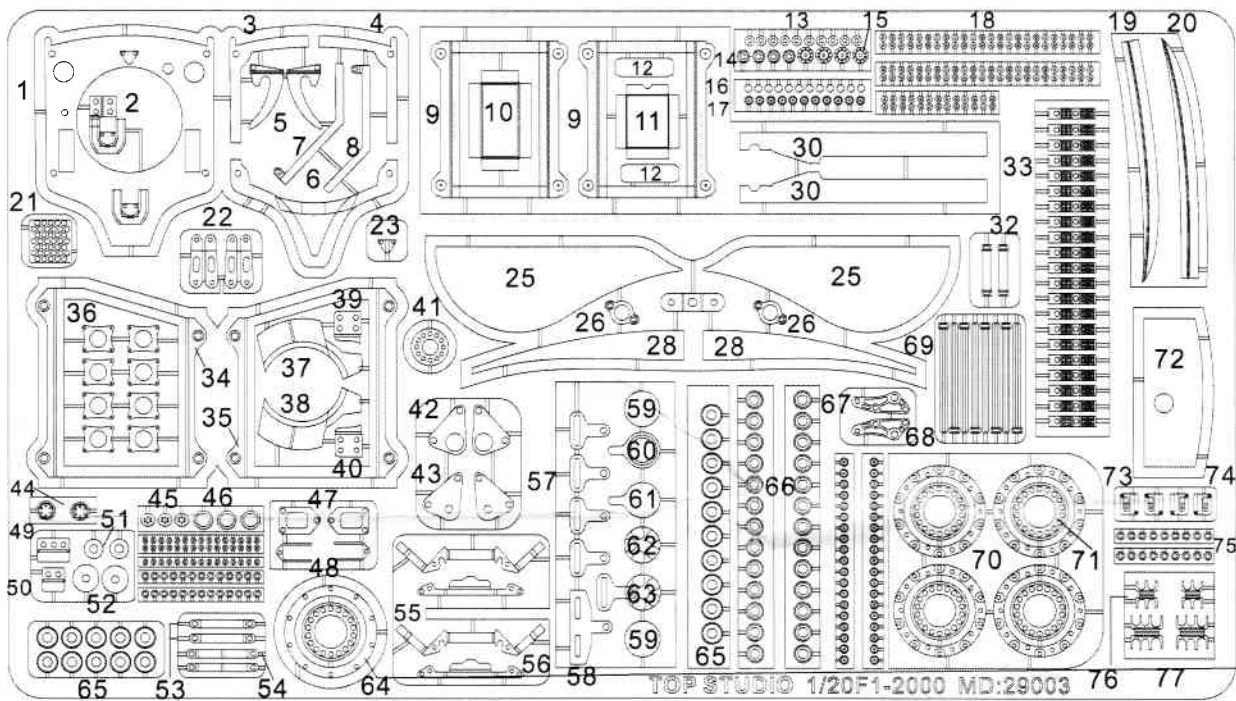

金屬部件
Metal Parts

樹脂部件
Resin Parts

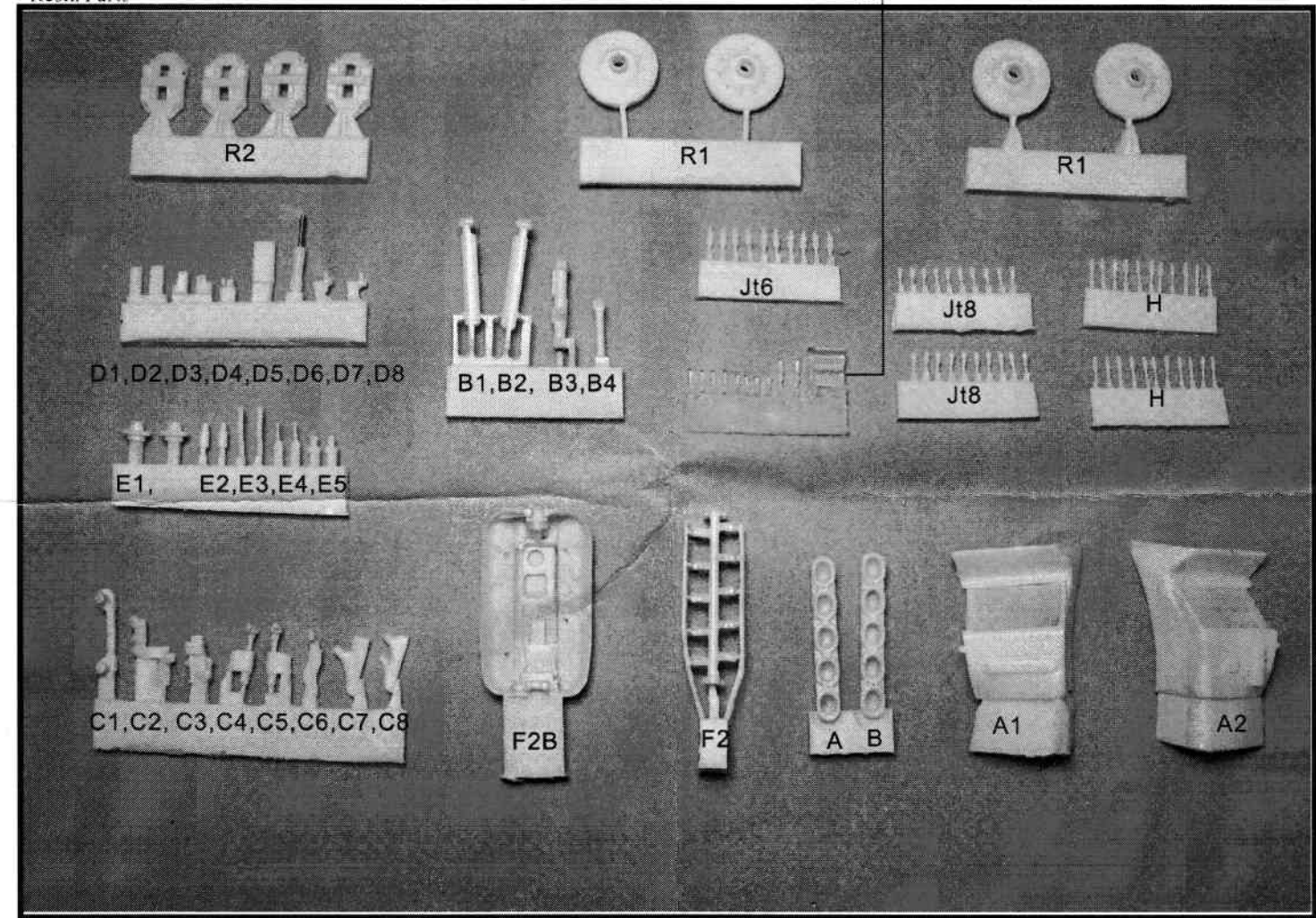

- 其它配件:**
Other materials
- 0.3mm鋼線 ×1
0.3mm metal wire
 - 紅色絲帶 ×1
red ribbon
 - 白色布 ×1
white cloth
 - 鋁箔貼紙 (用于制作隔熱層) ×2
metal foil sticker (using as heat shield)

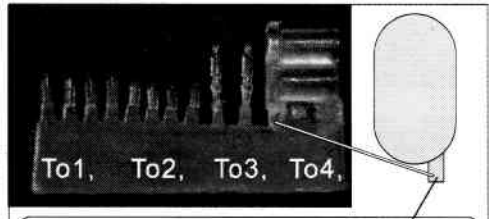

注意這根柱，不要切除，把它固定在PE1
Pay attention to this pole, don't cut it off.
Fix it over Pe1